

# Application Note

## Roll Alignment

### System Recommendations:

Printing Presses/Paper Machines

L-742 Ultra-Precision Roll Alignment System

Rubber Mills/Textiles

L-732 Precision Roll Alignment System

## How the Laser Alignment Systems Work - Reference Roll Procedure

### Horizontal Roll Parallelism

When aligning rolls for paper mills, printing presses or film lines, the most difficult alignment is the horizontal parallelism (levelness or vertical parallelism can easily be checked using a machinist level). The following section provides suggestions for choosing a reference and step-by-step procedures for equipment setup and performing an alignment.

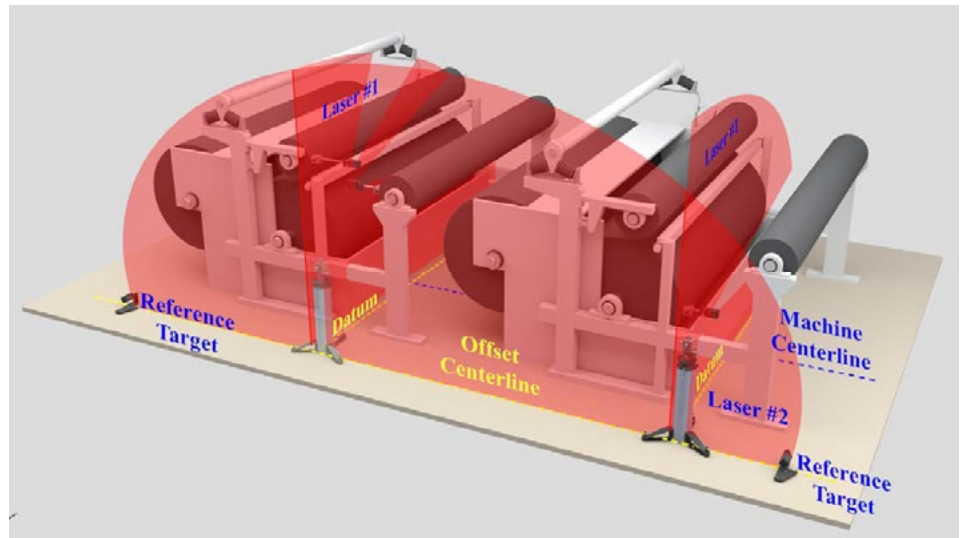

L-742 Roll Alignment System Showing Laser Transfer Method

### Choosing a Reference for Roll Alignment

Conventional methods of roll alignment usually use floor benchmarks (monuments) at the side of the machine as references. The L-742/L-732 offer the versatility of using these benchmarks or of picking up a reference roll, such as a cooch roll on paper mills. We strongly believe that using a reference roll provides the most accurate reference and results in better alignments.

Benchmarks are usually set in a thin concrete floor, are rarely covered, and are routinely run over and nicked. More importantly, they move with the slab of concrete and rarely hold their position relative to the mill itself. Most floors in a typical plant have multiple slabs and are usually cracked throughout, creating instability of the monuments. Unless checked every time, the use of the benchmark probably will result in significant alignment errors.

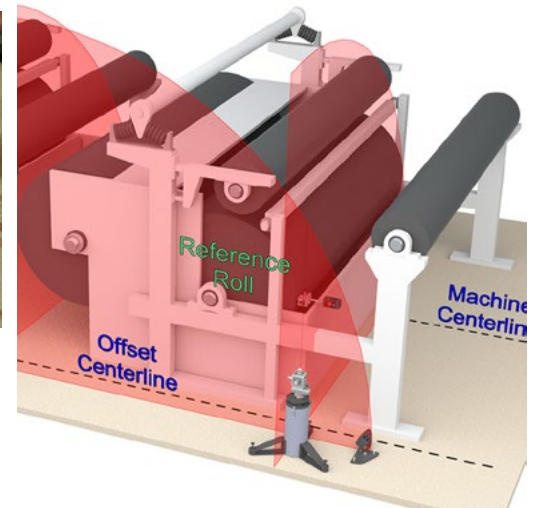

Hamar Laser Instruments, Inc.  
5 Ye Olde Road Danbury, CT 06810  
Phone: 800.826.6185 Fax: 203.730.4611  
Int'l: +1.203.730.4600  
E-mail: [sales@hamarlaser.com](mailto:sales@hamarlaser.com) [www.hamarlaser.com](http://www.hamarlaser.com)  
[Click here](#) for a list of our distributors.



## L-742 Roll Alignment using a Reference Roll - Procedure

Here's how the process works for picking up a reference roll: (keep in mind that using the L-742WW or L-732WW is like having two walls, both perpendicular to each other, 100 feet (30.5 M) in radius and very flat).

1. Place the L-742 on the L-106 stand outside the machine near the reference roll, at the side of the machine and level it. The L-742's Laser Plane #1 (LP#1) should be about 5 in. from the side of the roll to allow space for the A-1519-2.4ZB Targets to measure the roll.

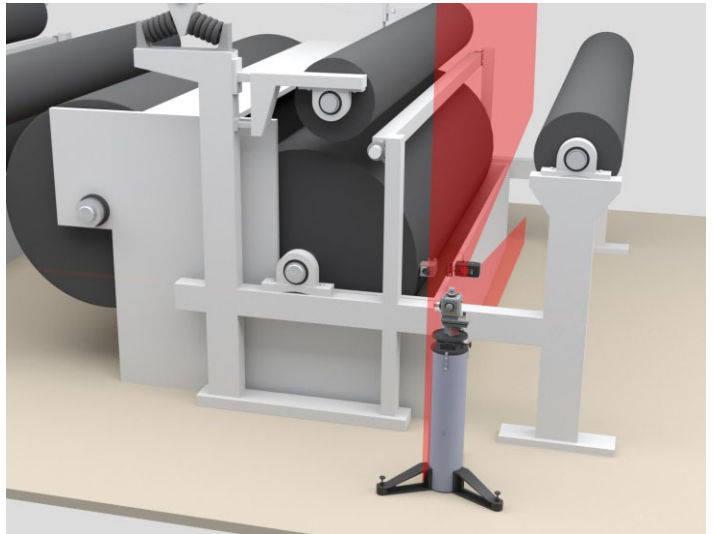

2. Place A-1519-2.4ZB Target #1 on the reference roll horizontally at the closest point to the laser and mark the location on the roll. Slide the magnetic base slowly up/down (or rotate the roll) until the bubble is centered on the bulls-eye level. This puts the target at the Top Dead Center (TDC) of the roll.



- Adjust the height of the target by loosening the thumb screw and sliding the post in/out of the magnetic base until the target detects the laser plane.

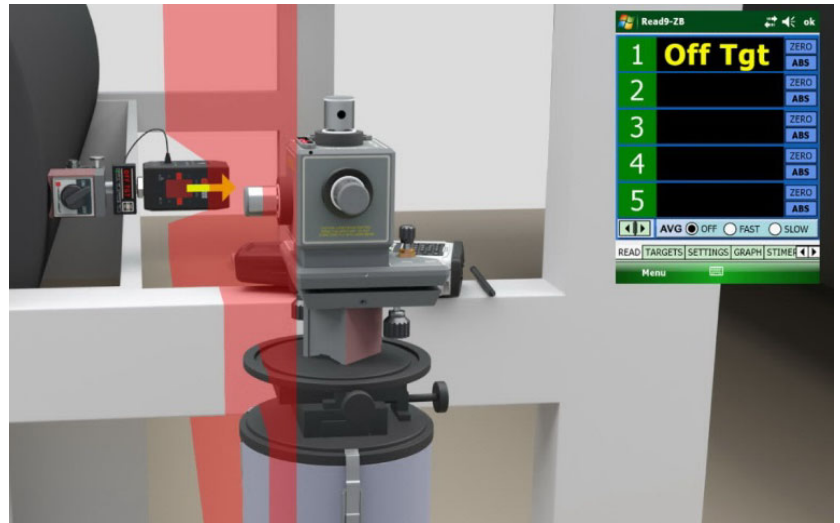

- Zero the value for Target 1 using Read15 in the R-1356-2.4ZB PDA Readout and move the target to the far end of the roll.



- “Buck in” or tilt Laser Plane #1 (LP#1) using the Yaw Adjustment until Target #1 reads zero at the Far Point. Move Target #1 back to the Near Point, re-zero, and repeat the process until the target reads zero at both locations, which usually takes 2-3 tries. If using the Remote Buck-in Formula (see Page 10), this process can be done in one pass.

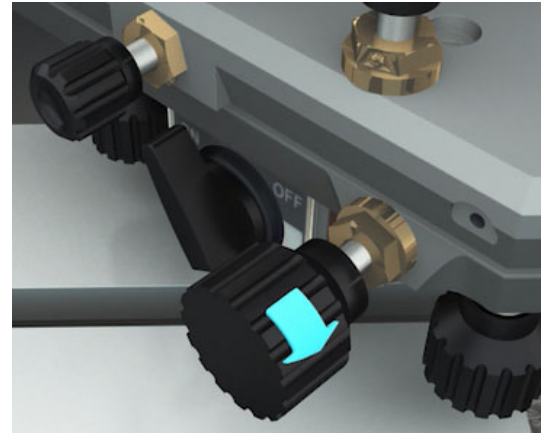

*Yaw Adjustment Knob on L-124 PRY Base*

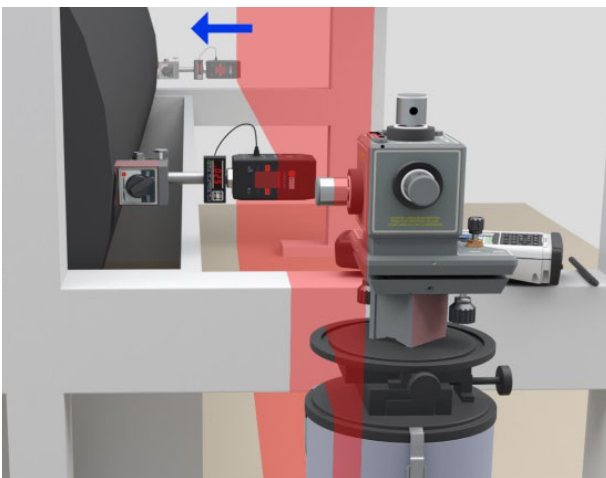

*Adjusting the Yaw Axis moves the vertical laser plane left or right to align it to the roll*

- The laser plane is now parallel to the reference roll.

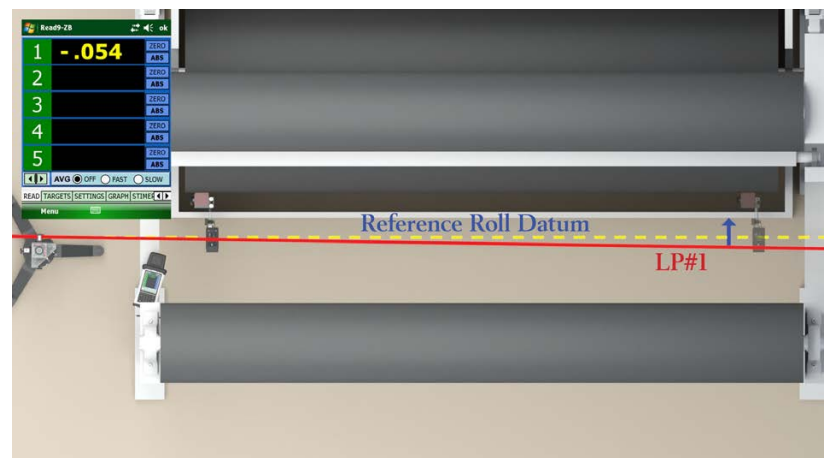

*Top View showing the laser plane moving in the Yaw Axis to the Reference Roll Datum*

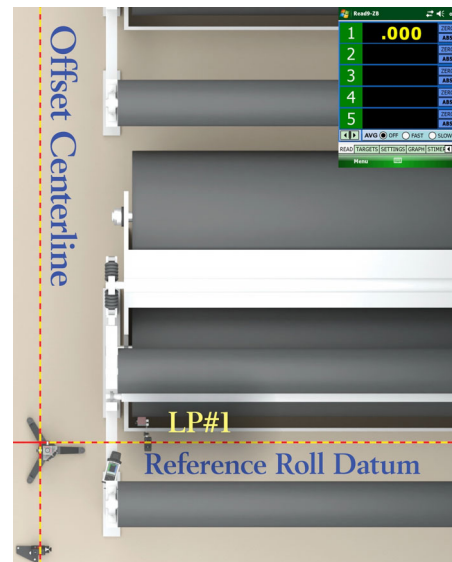

- Laser Plane #1 is now parallel to the Reference Roll Datum (centerline of the roll).
- Laser Plane #2 is perpendicular and is now parallel to the machine’s centerline but offset to the side of the machine.



- Since the LP#2 is perpendicular to LP#1, LP#2 becomes the *offset centerline* of the mill. This *offset centerline* has a range of 100 feet (30.5 meters) on either side of the laser and can be transferred as many times as needed to align even the longest machines.



- Place Target #2 and #3 on floor fixtures at both ends of the machine and adjust until the laser beam hits the middle of the target windows. Turn on LP#2 and zero the values for targets in Read15, establishing the *offset centerline*. These targets are *not* touched during the remainder of the alignment.

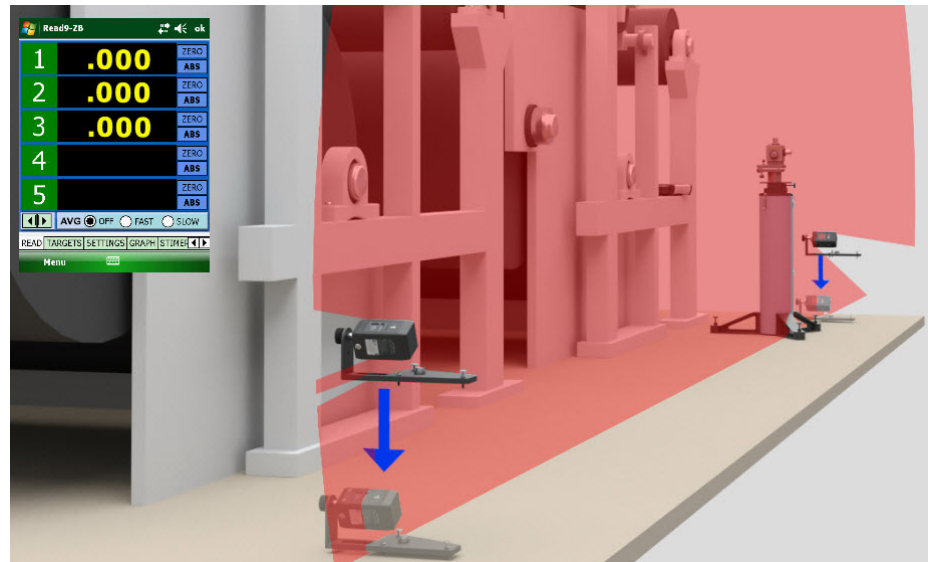

*Placing A-1519-2.4ZB Targets in Floor Fixtures to establish the Offset Centerline*

- To check the parallelism of a section of rolls, move the L-742 and L-106 stand along the *offset centerline* to the desired machine section and position the laser so LP#1 is about 4-5 in. from the roll to be measured. Level the L-742.

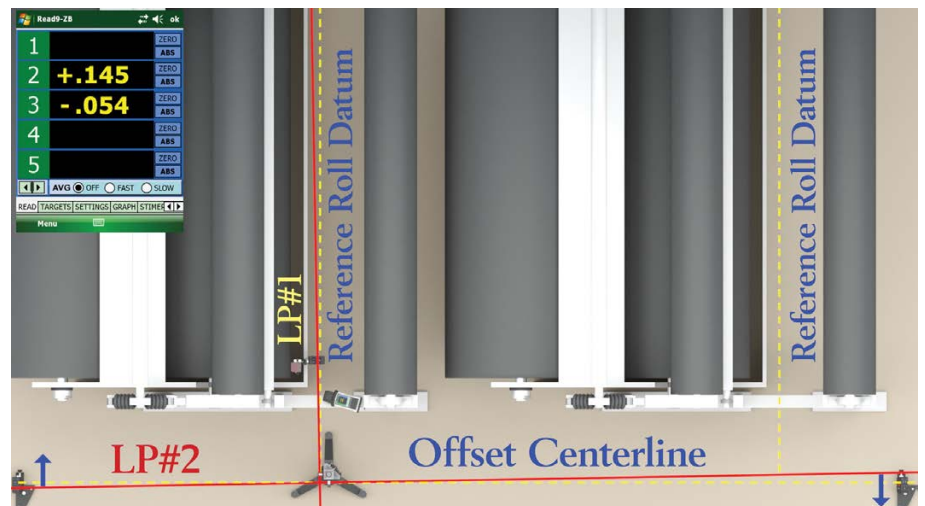

10. Adjust the yaw adjustment on the laser base so that LP#2 is tilted until both Target #2 and #3 show the same readings. LP#2 is now parallel to the offset centerline.

*Note: The readings do not have to be zero, but just the same number and same sign.*

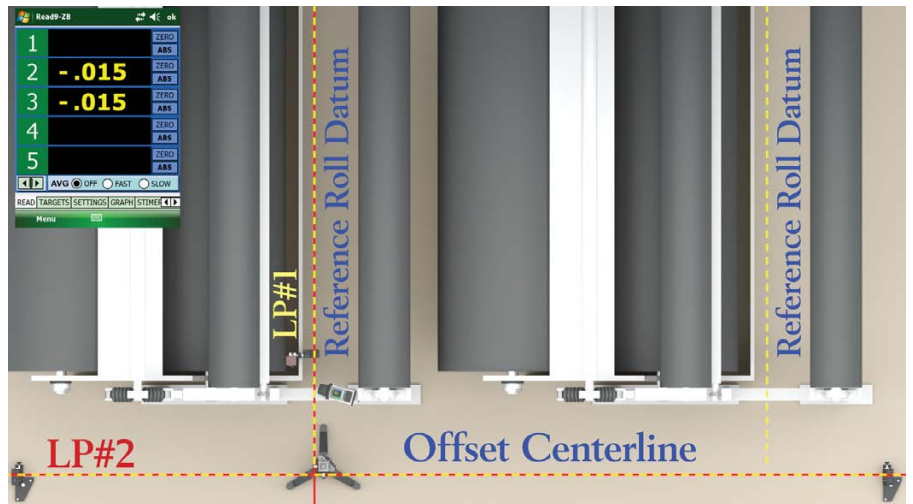

11. To measure one of the rolls for parallelism, place Target #1 horizontally on the roll closest to the laser. Adjust the post so the laser plane is near the center of the target window. Move the magnetic base up/down the roll until the bubble is level. Zero Target #1 in Read9.

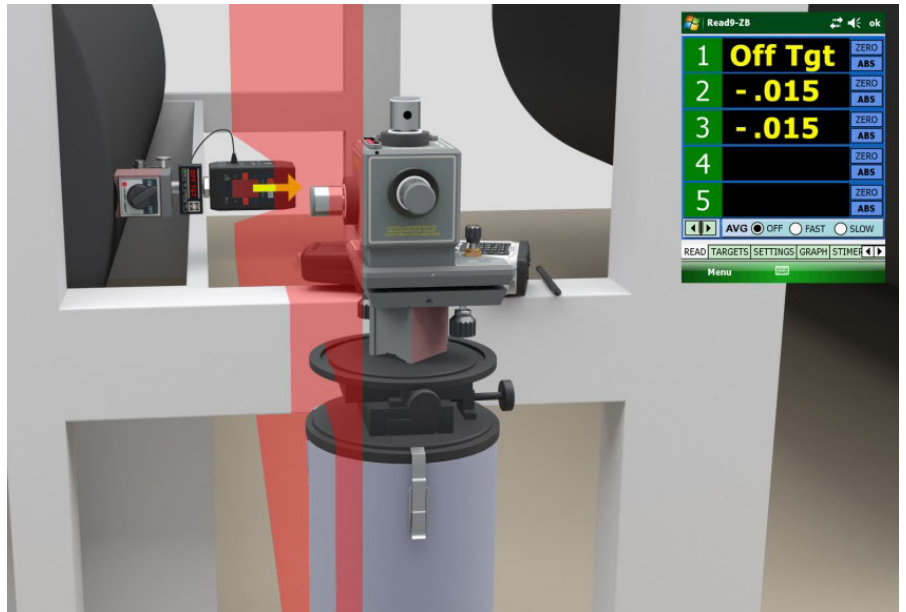

*Adjusting the post length for A-1519-2.4ZB Targets in mag base so it can detect the laser.*

12. Move Target #1 to the far end of the roll. The resulting value is a measure of the parallelism of this roll relative to the reference roll. In this case, a plus (+) reading means the far end of the roll is pointing to the right by .025 in.. To align it, adjust the roll until the readout shows zero, which means the roll is aligned and parallel to the reference roll.

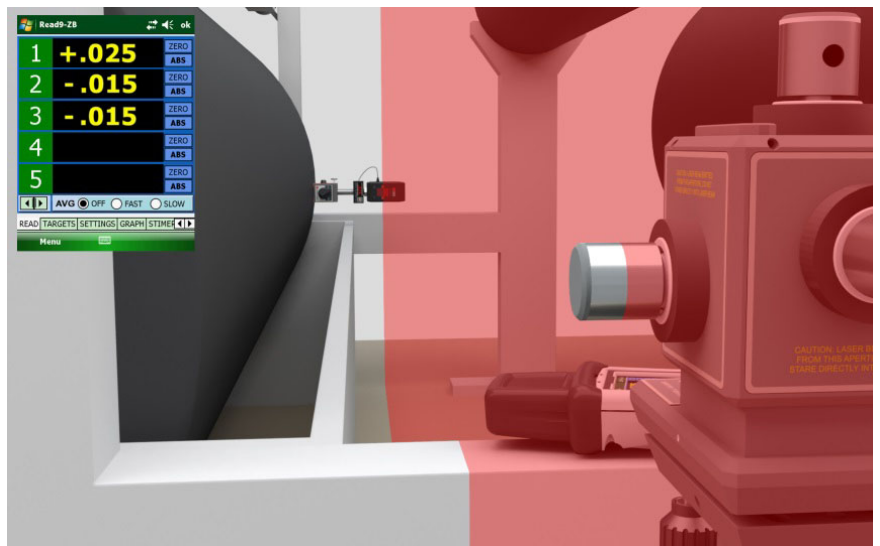

*A-1519-2.4ZB Measuring Target at the far end of the roll measuring the parallelism*

13. Since the laser generates a plane, rolls in the same machine section that are up to 100 feet (30 m) above the laser, and are within 2 feet (610 mm) horizontally of the laser plane, can be measured for parallelism without changing the setup of the laser.

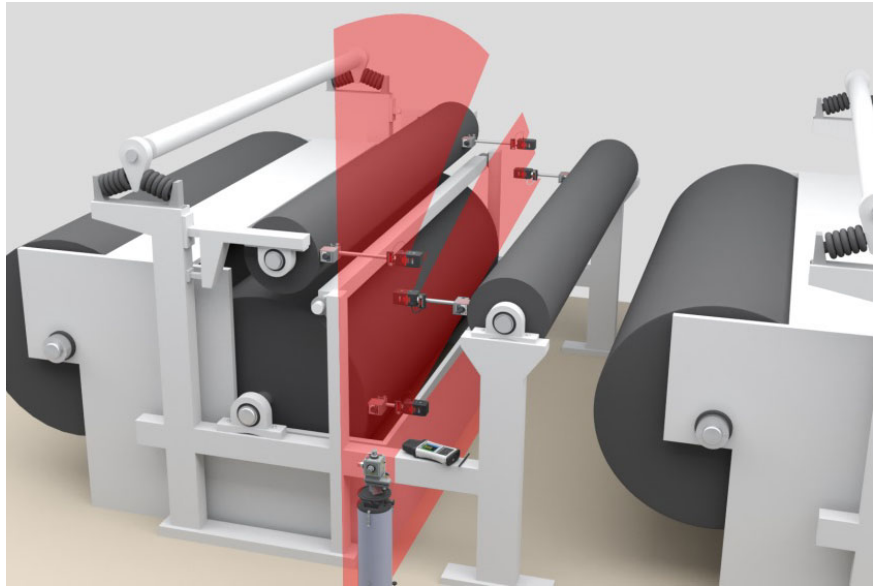

*L-742 Measuring plane can measure multiple rolls off the same setup just by moving targets to the near end of the roll, zeroing and measuring the far end for alignment. Rolls that are up to 100 feet (30 m) above the laser can easily be measured.*

### Arc Measurement Method - Sweeping Through the Arc

For hard-to-reach rolls that are farther than 2 feet (610 mm) from the laser, or where the roll radius is greater than 2 feet, the Arc Measurement Method can be used to get accurate results. In this method, instead of using the bullseye level, the target is swept through an arc to find the Top Dead Center (TDC), or the highest point on the arc that is tangent to the laser plane. To do this, the target is attached to the roll and it is slowly rotated (or slid around it) until the highest value is determined (*see procedure below*).

### Arc Measurement Sweeping Through the Arc

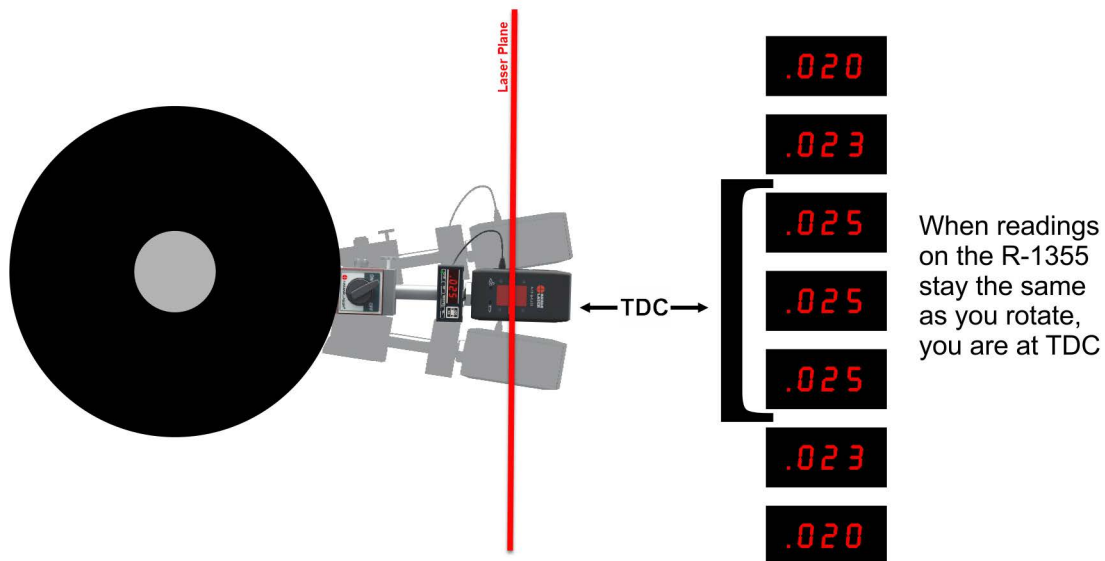

### Arc Measurement Method Procedure

1. Set up the A-1519-2.4ZB Target magnetic base (or use the T-1600 as described below). Ensure that the level on the magnetic base or fixture is centered, indicating you are close to TDC.
2. Slowly slide (or rotate the roll) the target magnetic base (or T-1600 fixture) around the roll in one direction while watching the R-1356 display. If you see the target reading *decreasing* in value, stop and rotate in the opposite direction. You will then see the target value *increasing*. As you continue to sweep through the arc, you will notice the value stops increasing for a short time, and if you continue to rotate in the same direction, then you will notice the value will start to decrease again.
3. The highest reading (most positive or least negative) occurs when the target is at the TDC. This is the value to record as the measurement for that point.
4. This method should work for roll diameters or target rod lengths up to 6 feet (2 m).



### Remote Buck-in Formula

Many times in Roll Alignment, the laser has to be far from the edge of the machine. In this case, the normal buck-in process does not work very well. To circumvent this, we use the Remote Buck-in Formula:

**Set Point =  $-1 * (D1/D2) * \text{Far Reading}$ , where:**

*D1 = distance from laser base to Near Point target location on the roll.*

*D2 = distance from the Near Point target location to the Far Point target location on the roll.*

*Far Reading = the value in the PDA with the target zeroed at the Near Point and moved to the Far Point.*

After calculating the Set Point, put the target back on the Far Point. Then adjust the L-742's Yaw Axis until the target value equals the Set Point. When you move the target back to the Near Point, you will see the reading is the same as the Set Point. This means it's bucked in. Taking care with the dimension measurements will result in doing the buck-in in one pass.

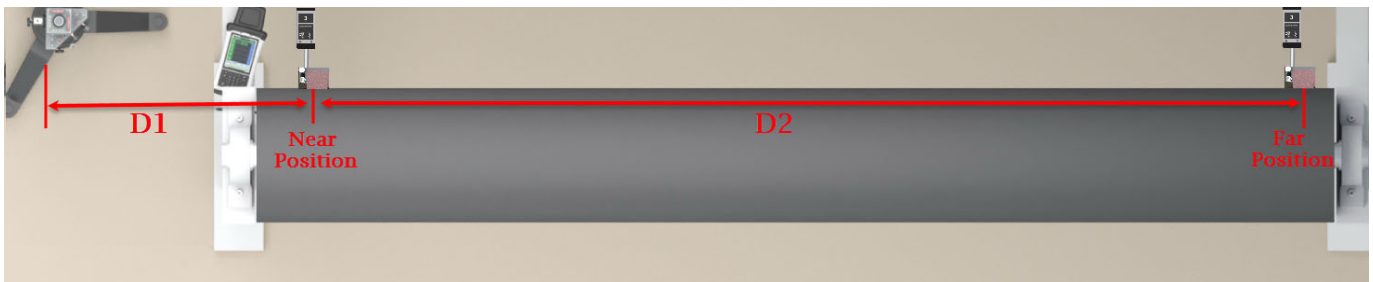



## Tramming Method for Hard-to-Reach Rolls

1. There are times when the side of the roll is impossible to reach with the target. In this case, we can attach a tram bar to the end of the shaft and put the A-1519-2.4ZB Target on it. Rotate the shaft to 12:00 and zero it in Read15. Then rotate it to 6:00 and the deviation is a measure of how out of level the roll is *relative* to earth level since the laser has been leveled.

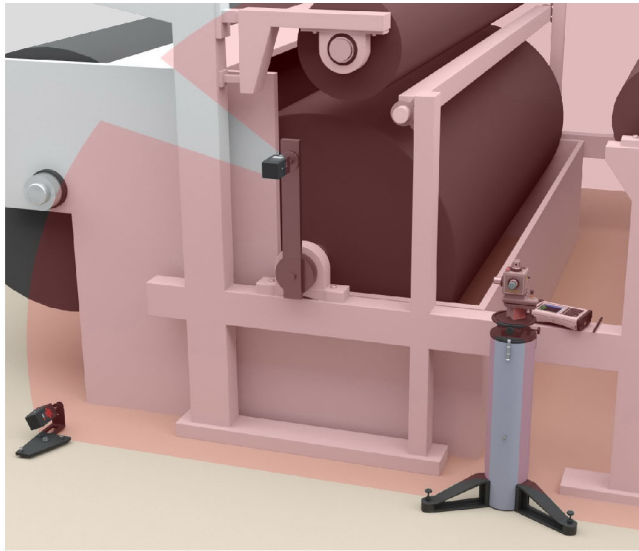

A-1519-2.4ZB Target at 12:00

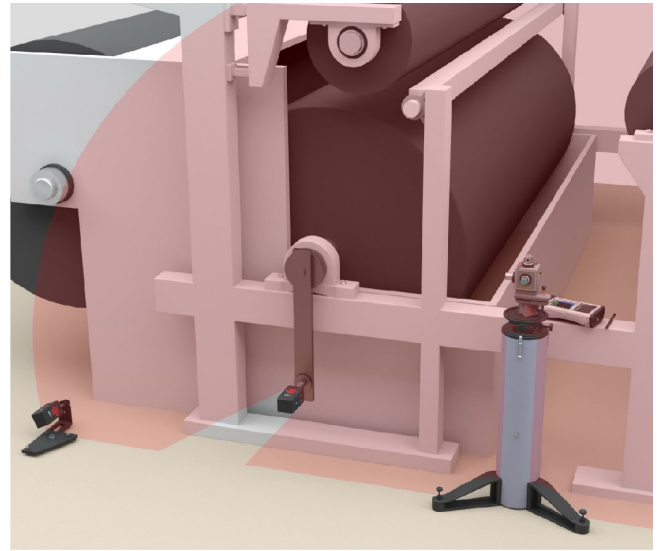

A-1519-2.4ZB Target at 6:00

2. For the horizontal parallelism, rotate the shaft to 3:00 and zero it. Then rotate it to 9:00 and this gives you a measure of how out of parallel the roll is *relative to the reference roll*.

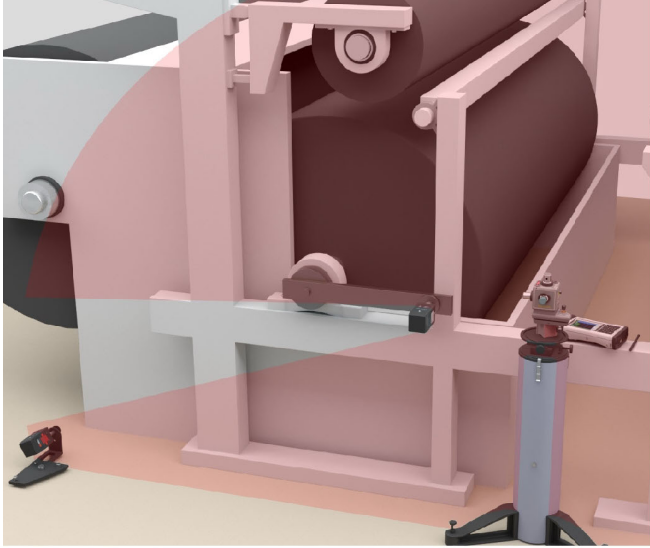

A-1519-2.4ZB Target at 3:00

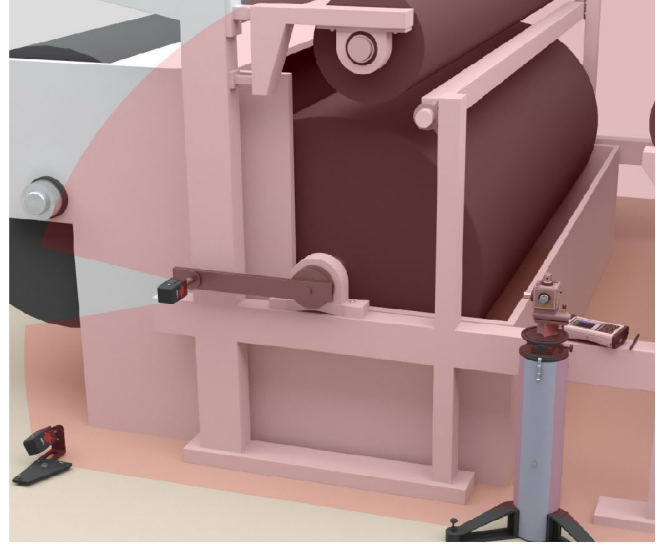

A-1519-2.4ZB Target at 9:00

**Note:** If the tram bar radius is 18 in. (500 mm) long and the difference in the reading is .009 in. (0.23 mm), then that equals a parallelism error of .003 in/ft (0.25 mm/m) ( $.009 / 36 \text{ in.} = .003 \text{ in/ft}$ ). If the roll is 15 feet (4.5 m) long, then this means the far end of the roll is out by .045 in. (1.14 mm) relative to the reference roll.

### Leveling Rolls

For checking level on applications with multiple rolls in or near the same horizontal plane, you can upgrade to the L-743 or L-733 Triple Scan® lase, which add a horizontal laser plane to the 2 vertical planes in the L-742WW or L-732WW.

To level a roll, the laser is leveled and a target is placed on one end of the roll and zeroed using the Arc Measurement method. The target is then moved to the other end of the roll and the deviation from level is measured. If both readings are zero, then the roll is level. If not, it can be adjusted using the target as an electronic indicator.

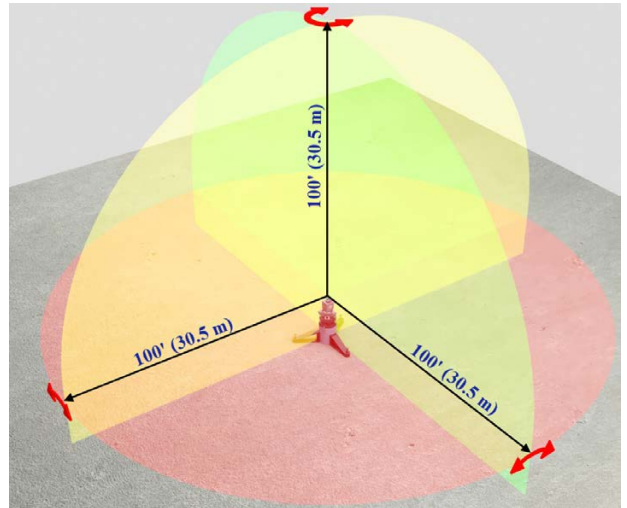

#### Arc Measurement Sweeping Through the Arc

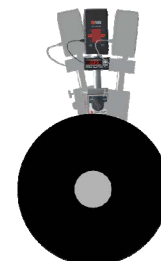
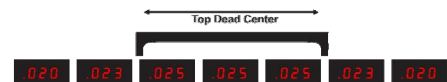

As the roll is rotated, when the readings stop changing, you are at Top Dead Center.

## The T-1600 Non-Magnetic Roll Fixture for the A-1519-2.4ZB Targets

The T-1600 Non-Magnetic Roll Fixture is used for aluminum, rubber and stainless-steel rolls. Also available is the T-1601 Tight Space Roll Fixture/Tram Bar, which uses two A-1519-2.4ZB Targets to measure alignment in tight spaces. The following procedure describes the setup and procedure for using the T-1600.

