

*L-703SP Surface Plate
Calibration System*

*April 2026
Revision C5*



HAMAR LASER INSTRUMENTS, INC.
www.hamarlaser.com

5 Ye Olde Road, Danbury, CT 06810
+1 203-730-4600

WARRANTY

Hamar Laser Instruments, Inc., warrants each instrument and other articles of equipment manufactured by it to be free from defects in materials and workmanship under normal use and service, its obligation under this warranty being limited to making good at its factory any instrument and other article of equipment which shall within one year after shipment of each instrument and other article of equipment to the original purchaser be returned intact to Hamar with transportation prepaid, and which Hamar's examination shall disclose to Hamar's satisfaction to have been thus defective; other than this express warranty, Hamar neither assumes nor authorizes any other persons to assume for it any other liability or obligation in connection with the sale of its products.

This warranty is not applicable to instruments or other articles of equipment manufactured by other companies and limited by a warranty extending for less than one year. In such an event, the more limited warranty applies to said instrument or article of equipment.

This warranty shall not apply to any instrument or other article of equipment which shall have been repaired or altered outside the Hamar factory, nor which has been subject to misuse, negligence, or use not in accord with instructions furnished by the manufacturer.

The software described in this manual is furnished under a license agreement and may be used or copied only in accordance with the terms of the agreement. It is against the law to copy the software on any medium for any purpose other than the purchaser's personal use.

The information in this manual is subject to change without notice. No part of this manual may be reproduced by any means, electronic or mechanical, without written permission from Hamar Laser Instruments, Inc.

**© Copyright Hamar Laser Instruments, Inc., 2025
5 Ye Older Road, Danbury, Connecticut 06810**

Table of Contents

L-703SP Surface Plate Calibration System	1
L-703SP Surface Plate Calibration System - Hardware Overview	3
L-703S Angular Adjustments	4
L-703S Level Vials	5
The T-1297 3-Axis Wireless Spindle & Straightness Target.....	5
How to Use the T-1297 Targets	5
How to Pair the T-1297 Target's Bluetooth to a PC	7
L-703SP Surface Plate Calibration System - Fixture Overview.....	9
A-1297-SP High Accuracy, Flatness Measuring Base for T-1297 Target.....	12
A-703SP-SE-A/B/C/D Target Straight-Edges and Rulers	13
Selecting Straightedge Length	14
A-703SP-SE-CLT Corner-Locating Tools.....	15
A-808-1297-DM Target Calibration Fixture.....	16
Preparing for an Alignment	17
System Warmup Period.....	17
Cleaning the Plate.....	17
Maintenance and Cleaning of L-703SP & T-1297.....	18
S-1409 Plane6 Surface Plate Calibration Software - System Requirements	20
Installing Plane6.....	20
Getting Started with Plane6	21
Hamar Product Registration	21
Authorizing Lapping Line View™	22
Creating a New Project File or Opening an Existing Project File.....	23
Converting Raw Data Values in CSV files to Inches or Millimeters	24
Plane6 Software – Summary of Main Screens	25
Plane6 Screens - File Menus.....	27
Plane6 Screens - Preferences	29
Targets – Setup Procedure.....	31
Plane6 Screens - Step 1: Dimensions and Tolerances	34
Plane6 Screens - Step 2: Data Collection – Plate and Line Views	36
Plane6 Screens - Step 3: Results.....	41
Plane6 Screens - Step 4: Graph.....	43
L-703SP - How It Works	48
Step-by-Step Surface Plate Calibration Procedure	48
L-703SP - How to Do a Reverse Line Check.....	59
L-703SP - How to Take a Data Point without a Straightedge	62
How It Works – Plane6 Step 2 - Line View	64
Performing a Flatness Quick-Check on a Line Segment after Lapping	64
Printing the Report.....	68
Appendix A – Installing Additional Microsoft Software	70
Appendix B – ANSI B89.3.7.2013 Standard Tolerance Table.....	71
Appendix C -Troubleshooting Guide.....	72
Appendix D - How to Calibrate the T-1297 Target.....	74

L-703SP Surface Plate Calibration System

The L-703SP Surface Plate Calibration System has been designed to quickly and very accurately check the calibration of surface plates using the Moody Method, following the ASME B89.3 Standard for Surface Plate Calibration. It uses Plane6 Surface Plate Calibration Software and specially designed fixtures to give a high degree of accuracy when calibrating surface plates.

System Components

The L-703SP Surface Plate Calibration System includes the following components:

- L-703S Spindle & Straightness Laser
- T-1297 3-Axis Wireless Straightness Target with .00001 in. (0.25 μ m) Resolution, 10x10 PSD, Bluetooth & Center/Scan Mode
- A-703SP-LM Surface-Plate Mounting Fixture for L-703SP Laser
- A-1297-SP High Accuracy, Flatness Measuring Base for T-1297 Target
- A-703SP-SE-A Target Straight-Edge and Ruler – 18 in. (457 mm)
- A-703SP-SE-B Target Straight-Edge and Ruler – 36 in. (914 mm)
- A-703SP-SE-C Target Straight-Edge and Ruler – 54 in. (1,373 mm)
- A-703SP-SE-D Target Straight-Edge and Ruler – 72 in. (1,829 mm)
- A-703SP-SE-CLT-1.5 Corner & Midpoint Straight-Edge Locating Tool - Set of 2 for 1.5 in. border
- A-703SP-SE-CLT-2.0 Corner & Midpoint Straight-Edge Locating Tool - Set of 2 for 2.0 in. border
- S-1409 Plane6 Surface-Plate Calibration Software for Win 10/11
- A-818 Shipping Case for L-703/L-705 Spindle & Extruder Systems
- A-819 Shipping Case for L-703SP Straight-Edges and A-703SP-LM

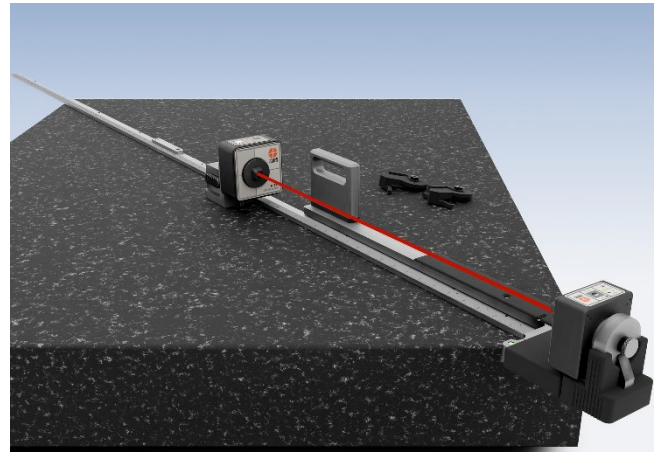

Optional Components

- A-703SP-SE-E Target Straight-Edge and Ruler – 12 in. (305 mm)
- A-703SP-SE-D-EXT-A 18 in. (457 mm) Target Straight-Edge Extension and Ruler for 72-90 in. (1.8-2.3 m) lengths
- A-703SP-SE-D-EXT-B 18 in. (457 mm) Target Straight-Edge Extension and Ruler for 90-108 in. (2.3-2.7 m) lengths
- A-703SP-SE-D-EXT-C 18 in. (457 mm) Target Straight-Edge Extension and Ruler for 108-126 in. (2.7-3.2 m) lengths
- A-703SP-LM-M “Mirrored” Surface-Plate Mounting Fixture for L-703SP Laser
- A-808-1297-DM Calibration Fixture for the T-1297 3-Axis Wireless Straightness Target

Computer System Requirements

- Physical memory (RAM): 8 GB recommended
- Processor: Intel Pentium4 or later version or AMD equivalent, 1.3 GHz minimum speed
- Available Hard Drive space: 20 GB minimum
- Video Resolution: 1366 x 768 minimum (32-bit color) with hardware acceleration and dedicated video memory.
- Windows 10/11 professional editions.
- Bluetooth 2.0 and higher

L-703SP System Features

- Geometry laser, not interferometer with resolution of 10 μ m. (0.25 μ m).
- Fast, easy setup – 30-40% faster than levels
- Super-linear PSD sensor with <0.25% measurement error

- Bluetooth wireless with 100 ft. (30 m) range
- 3-point measuring base accommodates nearly any measuring increment
- Kit includes a set of straight-edge rulers for fast setups for plates up to 72 in. diagonal. Optional add-on straightedges are available for diagonals up to 126 in. (3.2m).
- Also includes corner & midpoint, straightedge-locating tools to position the straightedge so that the target is located directly on the measurement line.
- Plane6 Surface Plate Calibration Software corrects setup errors and quickly records data, producing a calibration report with a graph
- Plane6 software runs on most typical Windows® laptops/tablets running Win 8/10/11.
- Li-Po rechargeable batteries for laser/ target with 14+ hrs life

L-703SP Surface Plate Calibration System - Hardware Overview

This section describes the equipment and operation for calibrating surface plates using Hamar Laser's L-703SP Surface Plate Calibration Laser System. The system includes the laser, targets, fixtures, and software.

L-703S Spindle & Straightness Laser - Features and Setup

- Operating range of 50 ft. (15 m).
- Pitch and yaw angular adjustments with a resolution of .00002 in/ft (1.6 $\mu\text{m}/\text{m}$) and adjustment range of $\pm 0.36^\circ$ (± 0.075 in/ft. or ± 6.26 mm/m).
- A .4995 in. (12.69 mm) mounting stud with the laser beam concentric to $< .0003$ in. (0.008 mm).
- Under good environmental conditions, it is accurate to .0015 in. (0.075 mm) in 50 ft. (15 m).
- Rechargeable Li-Ion battery with 20+ hours of battery life.



Figure 1 - L-703S Laser

The L-703S is mounted directly in the A-703SP-LM Surface-Plate Mounting Fixture and aligned to the T-1297 Target located at the end of the line segment. This provides a straight reference line for checking the flatness of the line segment and the rest of the surface plate.

Applications include:

- Surface plate calibration
- Linear guideway straightness
- Flatness/straightness of large parts

L-703S Laser Control Panel and Functions

The I/O and Status LEDs

- *Battery Status LED* – green – normally it is off.
 - Blinks when the battery is low.
 - Solid green when the battery is charging. Turns off when the battery is fully charged.
- *I/O LED* – indicates the laser is turned on. This is also the mode indicator for the laser mode (see Laser Modes below).

The On/Off Button

Press the **I/O** button once to turn it on and *press and hold* for 3 seconds to turn it off. The I/O LED will illuminate when the power turns on.

L-703S Laser Modes

There are 2 laser modes:

1. **Double-Blink Mode** (default) – this is used for the T-1294, T-1295/T-1296/T-1297 Targets only. The I/O LED will blink twice and pause, blink twice and pause, and will do this continuously.
2. **Fixed (Continuous) Beam mode** – the laser beam is turned on continuously and does not blink. This is used for legacy targets using the R-358 Computer Interface or R-307/R-307V Readouts. The I/O LED will be continuously on (no blinking).

To change the mode, press the **I/O** power button once – do not press and hold, just press one time.

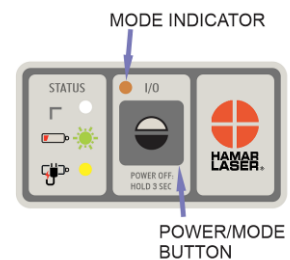

Figure 2 - L-703S Power Overlay

A/C Connector

The L-703S comes with a rechargeable battery. The connector is shown in *Figure 3*. To connect it, line up the red dot on the A/C adapter plug with the red line on the connector.



Figure 3 - The L-703S - Laser A/C Adapter Connector

L-703S Angular Adjustments

The L-703S comes with pitch (vertical) and yaw (horizontal) angular adjustments to adjust (tilt) the laser to align it to reference points or a rotation axis. The angular adjustments have a resolution of .00002 in/ft (0.0016 mm/m) and an adjustment range of $\pm 0.36^\circ$ (± 0.075 in/ft or ± 6.26 mm/m)

<i>L-703 Specifications</i>		
Beam Centering to Mount	.0003 in.	0.008 mm
Angular Range (slope)	± 0.08 in/ft.	6.6 mm/m
Angular Range (deg.)	± 0.38 deg.	
Angular Resolution	.00002 in./ft.	0.0016 mm/m



Figure 4 - L-703S Laser showing Pitch & Yaw Adjustments

L-703S Angular Adjustments – Returning Adjustments to the Center of their Range

To start an alignment, it is best to return the L-703S's angular adjustments to the middle of their range. The middle of the range is when the knob is flush with the overlay (see below). If the knob is unscrewed all the way, then knob will come out but this will not harm the mechanism, so just screw it back in. If the knob is screwed in, then it will also go into the face plate about .25 in. (10 mm).

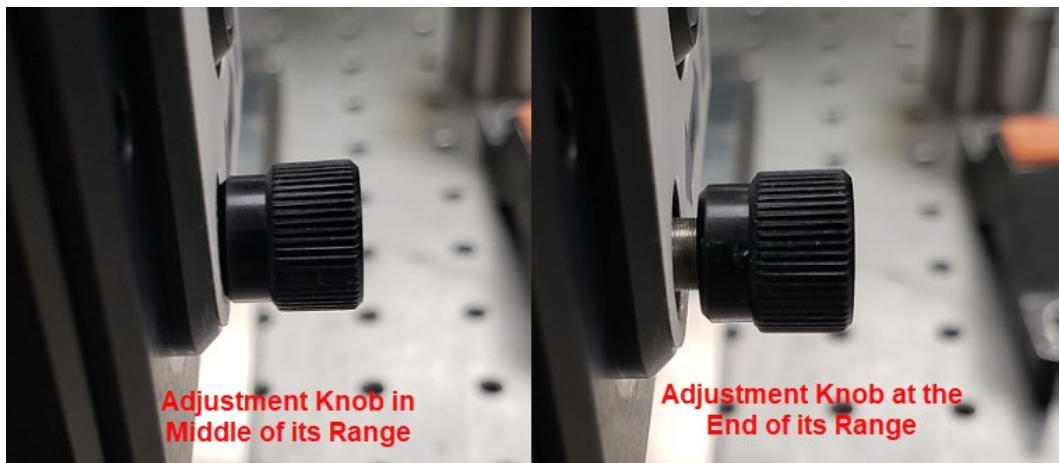

L-703S Level Vials

When using the L-703S in machine tools, we typically will do measurements with the laser at the NORMal position (12:00) and then rotated with the spindle 180 degrees to the INverted position (6:00). There are level vials on the *side* of the laser to help you know if the laser is directly at 12:00 or 6:00. However, this is not typically used in surface plate calibration, so they are not used in this application.

To use the level, rotate the laser 90 degrees so that the control panel is on the side (i.e. at 3:00 or 9:00). Then, slowly rotate the spindle until the bubble is centered in the circle. This indicates the laser is ready to be aligned to the rotation axis.

Note - the levels are not used in surface plate calibration applications.



Figure 5 - L-703 Level Vial

The T-1297 3-Axis Wireless Spindle & Straightness Target

Hamar Laser's T-1297 3-Axis Wireless Spindle & Straightness Target is designed to work with our L-703S Spindle & Straightness Laser. With Bluetooth communication and multiple measuring axes, the T-1297 target is a multi-purpose target that can be used for many different applications.

- Offers 2 measurement modes:
 - ❖ *Center Mode* - 2-axis center measurement for use with the L-703S Spindle laser.
 - ❖ *Flatness (Scan) Mode* - single-axis flatness measurement for use with our series of auto-rotating lasers (L-730/L-740/ L-702SP) in Scan Mode. (*Note – Scan Mode is not used with the L-703S Laser, nor used for surface plate calibration.*)
- PSD (Position Sensing Detector) Size:
 - ❖ .39 x .39 in. (10x10 mm) PSD
- Resolution (2 axis & 1 axis): .00001 in. (0.00025 mm)
- Wireless communication via Bluetooth Class 2 radio with 30 ft. (10 m) of communication range.
- The measurement error is < 0.25% of the measurement
- PSD is concentric to the mounting stud to < .0003 in. (0.008 mm).
- The T-1297 is designed so the measuring plane of the target is located at the face plate of the mounting stud, so when used with the A-1297 High-Accuracy Flatness-Measuring Base, it achieves the highest accuracy possible.
- Accelerometer rotation axis (3rd axis) helps to orient the PSD sensor axes to the alignment axes of the spindle.
- Lithium polymer rechargeable battery with 14+ hours of battery life.

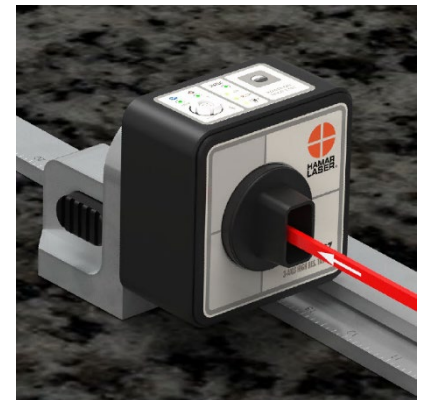

Figure 6 - T-1297 3-Axis Wireless Spindle &

How to Use the T-1297 Targets

The T-1297 Targets are designed for use with the L-703S in **Double-Blink Mode** (center/angular measurements) or **Scanning Beam Mode** (flatness measurements using one of our scanning laser plane lasers). The targets have a .4995 in. (12.69 mm) mounting stud for mounting spindles and fixtures, such as the A-1297 High-Accuracy Flatness Measuring Base.

Note – this section describes the full functions of the T-1297 Targets. For surface plate calibration applications, the L-703S Spindle Laser and the T-1297 are used only in Double-Blink Mode.

T-1297 Center Mode with the L-703S Spindle Laser

This is the default mode when the target is turned on and is what is used with the L-703S Spindle Laser and Plane6 Software. It is recommended while in **Center Mode** to use the light/dust shield, which is held in place with magnets. While in this mode, the values shown in Plane6 Software displays show the V & H center (offset) values of the target's mounting stud relative to the laser beam. It follows the same sign convention as shown on **Page 44, Interpreting the + and – Signs in the Live Displays**.

T-1297 Scanning Laser Mode - Optional

For applications other than surface plate calibration, the T-1297 Targets can be converted to Scanning Mode and used with the auto-rotating laser planes in our L-702SP and any L-730/L-740 Series lasers. These lasers automatically rotate to create a laser plane, which can then be measured with the T-1297.

Note: The T-1297 in Scan Mode is not compatible with the L-703S Spindle Laser

To change the T-1297 target into Scanning Mode, make sure the laser is *turned off* or the laser beam is blocked. Then press and hold the Power Button (see **Figure 7**) for 2 seconds. The **ON-TGT LED** will blink instead of being continuously on, as it is when it's in **2-Axis Center Mode**. To return the T-1297 to **2-Axis Center Mode**, power down the target and turn it back on.

Note: Plane6 Software does not support Scan Mode. To use Scan Mode, you must purchase MultiTurn10 or Plane5 Software. Please see those manuals for more details.

T-1297 Target LEDs

The T-1297 LED's have several colors and actions to indicate certain functions:

Bluetooth LED Green – means the target is connected to the computer

Bluetooth LED Green/Yellow – alternating green/yellow means the target is communicating with Plane6 software

On Tgt LED Continuous Green – means the target is detecting the laser beam in **Center Mode**.

On Tgt LED Continuous Red – means the target is not detecting the laser beam in **Center Mode**.

On Tgt LED Blinking Green – means the target is detecting the laser scan plane in **Scan Mode**.

On Tgt LED Blinking Red – means the target is not detecting the laser scan plane in **Scan Mode**.

Status LED Green – means the target is turned on.

Status LED Yellow - means the target is charging. It will turn off when fully charged.

Status LED Blinking Yellow – means the battery is low and the target needs to be charged.



Charging the T-1297

The T-1297 comes with a USB charging cable that plugs into the top of the target. Simply line up the red dot on the connector with the red dot on the female connector on the top of the target. You can use any standard USB A/C adapter to charge the target.



Figure 7 - T-1295/1296 Control Panel

Please note:

1. **The Status LED will flash yellow for 0.25 seconds and turn off if the battery is fully charged.**
2. **Charging the battery will generate heat and can cause thermal growth in the target, which could add additional uncertainty to the measurements. We recommend charging the target prior to starting the measurements. When the battery capacity gets low, it will also generate heat, so make sure to charge the battery when it gets below 20%.**

How to Pair the T-1297 Target’s Bluetooth to a PC

For your computer to see the Bluetooth device, you need to turn it on.

1. Tap on **Start** (the Microsoft Logo) > **Settings**.
2. Navigate to **Devices** and go to **Bluetooth**

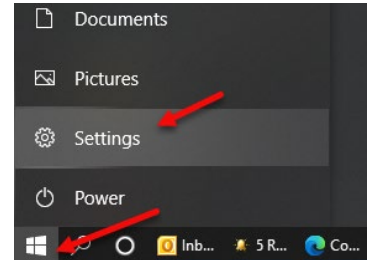

Or click on the **Bluetooth** icon in the system tray and click on **Add a Bluetooth Device**.

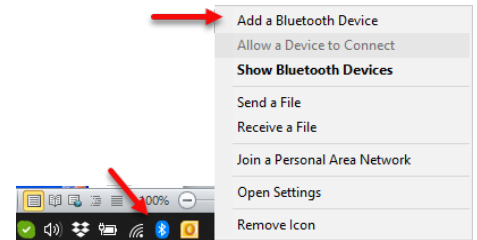

3. Make sure the Bluetooth toggle is in the **On** position. (You’ll know it is working because you’ll notice the message that reads “Your PC is searching for and can be discovered by Bluetooth devices.”)
4. Click on **Add Bluetooth or other device**
5. Select the device type you want to connect (usually you will select **Bluetooth**). You will see the devices listed under **Add a Device**.

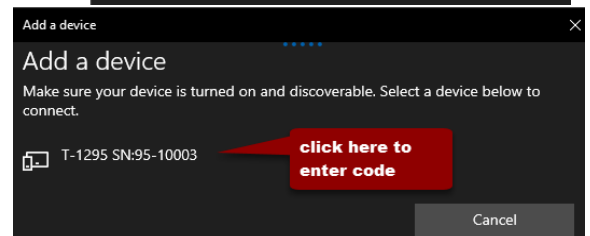
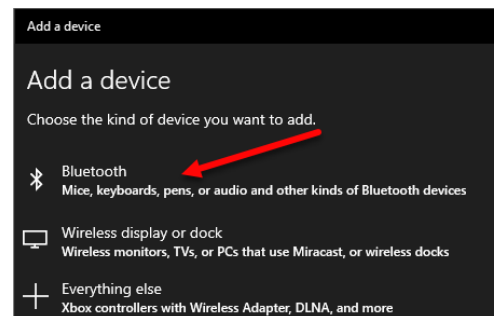
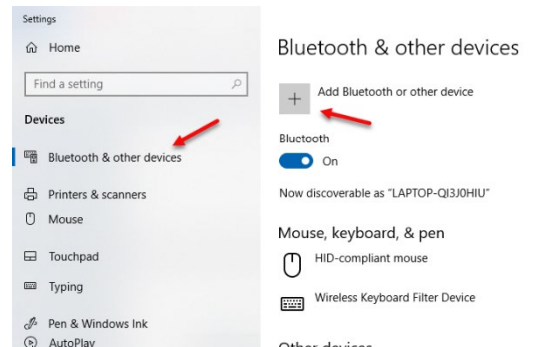

- Enter **1280** for the passcode when prompted and hit **Connect**. Your Target is now paired and ready to be used. Exit Settings window

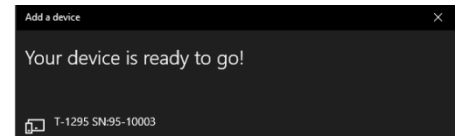
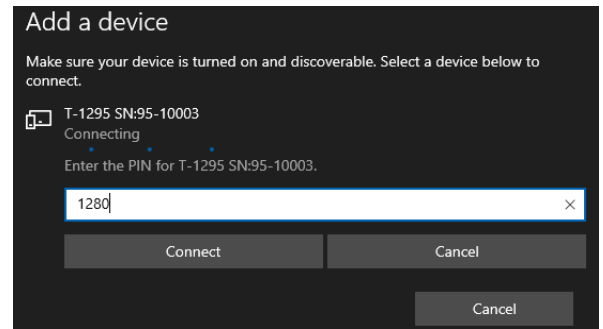

T-1297 USB Data Backup Communications Cable

The L-703SP's USB charging cable also functions as a data backup communications cable in case something happens to the Bluetooth connection. Here's how to connect it:

Important Note: To use the USB charging cable as a backup, you will need the Silicon Labs USB Driver installed on your computer **before** connecting the cable. Here is the [download link](#). Here is [more information](#) on the driver.

- Connect the cable to the top of T-1297 Target just as you would do to charge it (see pg. 6).



- Insert the USB cable into one of the USB ports on your PC.
- If Plane6 is running already, then make sure you are in Step 2. Wait about 20 seconds and you should see target values in the display area.

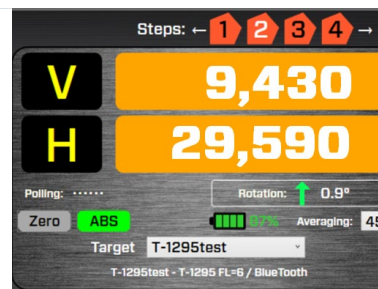

- If Plane6 is not running, then open the program, go to Step 2 and make sure you have the target selected in the dropdown box.
- After a few seconds, you should see target values in the display area.

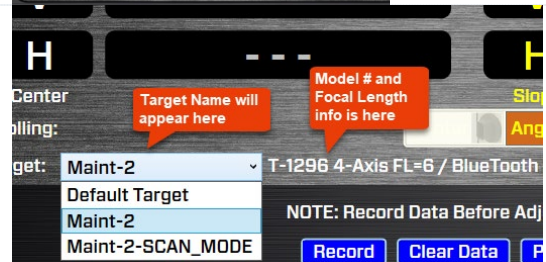

L-703SP Surface Plate Calibration System - Fixture Overview

A-703SP-LM Surface-Plate Mounting Fixture

To accurately measure the flatness of surface plates, the L-703SP requires a stable mounting fixture to hold the laser and a special flatness-measuring base for the target to achieve the highest accuracy possible.

The A-703SP-LM is used to mount the L-703S (see **Figure 8**) on flat surfaces for measuring:

- Flatness measurements of surfaces, such as surface plates.
- Flatness, straightness & squareness measurements of machine tool axes.

The A-703SP-LM-M is a “mirrored” version of the laser fixture for use on line segments that require the laser fixture position to be opposite of the normal position, such as when the plate is against a wall.

To secure the laser in the A-703SP-LM, insert the mounting stud into the .4995 in. (12.7 mm) mounting hole in the fixture. Then use the thumb screw to tighten the mounting stud. Make sure to make it very tight to ensure a rigid mount and avoid laser drift issues.



Figure 8 - A-703SP-LM Surface-Plate Mounting Fixture

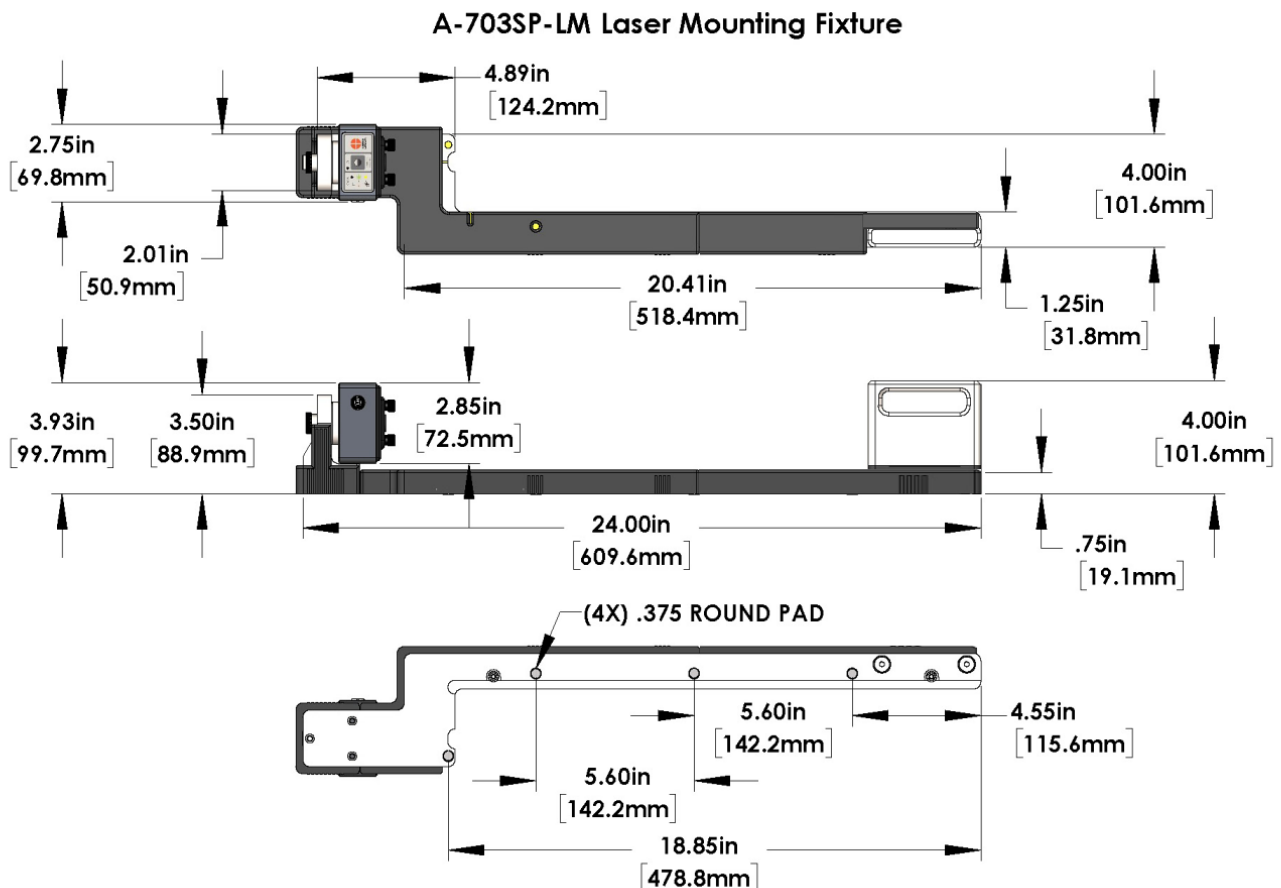

Figure 9 - A-703SP-LM Laser Mounting Fixture Dimensions

Please note - for surface plates smaller than 24 inches (611 mm), there is a second mounting foot (pad) location that is approximately 10 inches (250 mm) from the back mounting foot, so the A-703SP-LM can be used on plates as small as 12x12 in.

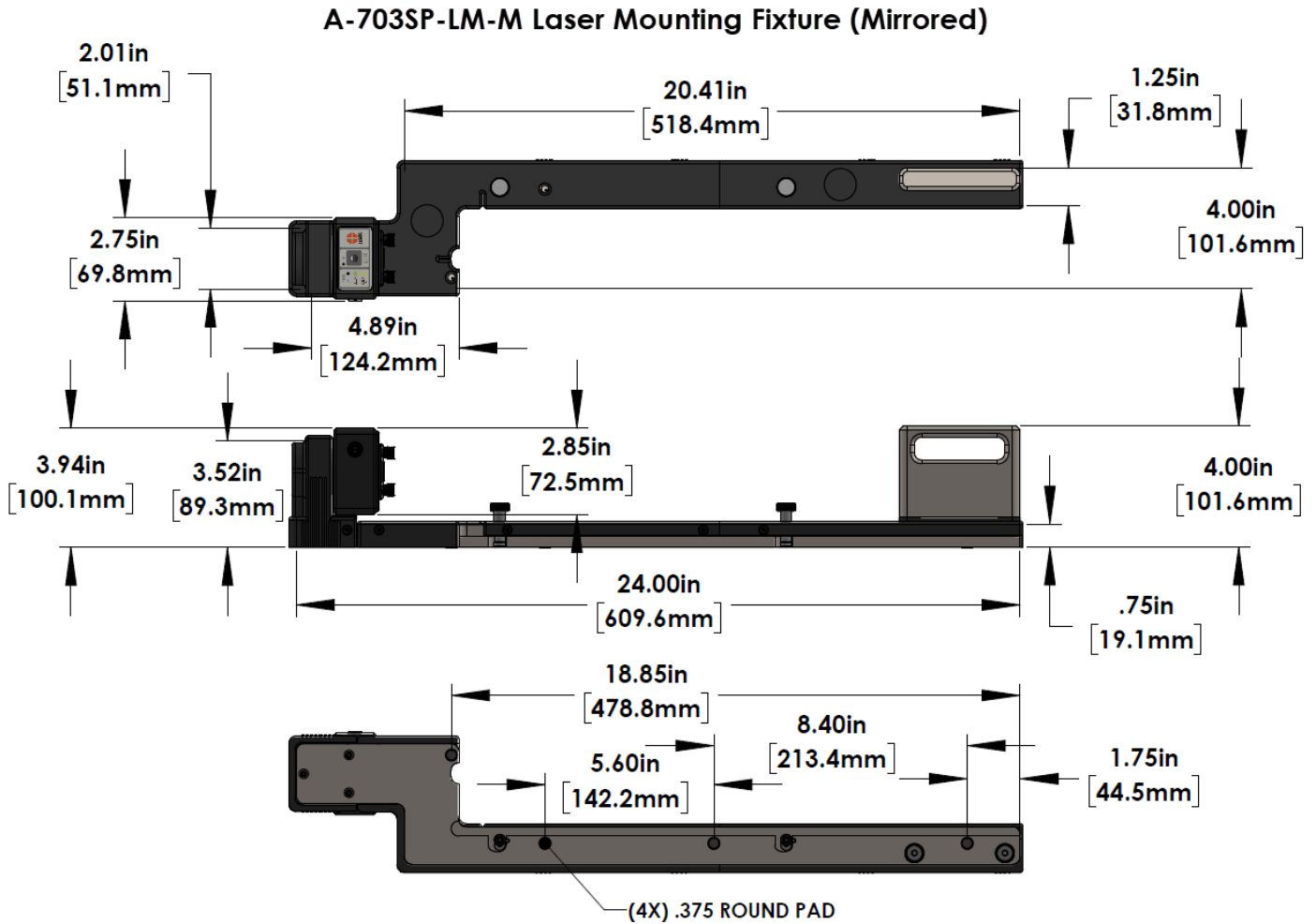

Figure 10 - A-703SP-LM-M “Mirrored” Laser Mounting Fixture Dimensions

*****Important Note when Handling the L-703SP-LM Laser Fixture*****

It is very important to only touch the plastic parts or the steel handle (see figure xx below) when moving the L-703SP-DM from line to line. If you touch some of the metal, the heat in your hand will cause the fixture to grow thermally, and this will happen remarkably fast! Keep in mind that a small growth in the metal upright can cause an angular change in the mounting surface, tilting the laser, which can turn into a significant change in the measurement value when the target is located several feet away.

We also recommend a short waiting period after positioning the A-703SP-LM fixture against the straightedge before taking data to maximize the stability of the laser fixture – see the table below. This waiting time gives the fixture time to settle down and stabilize.

Waiting Time - Laser Fixture	
Grade B	30-45 seconds
Grade A	60-90 seconds
Grade AA	90 to 120 seconds

Figure 11 - Laser Fixture Wait Times

Finally, do NOT touch the L-703SP-LM during the measurement of the line. This can cause the laser beam to move and add uncertainty to the measurement. If you do move the fixture, then make sure to move it back against the straightedge and wait 30-60 seconds for it to settle down. Hit **Clear Line** and then re-record the points.

Note - it is good practice when something moves the laser fixture (laser beam) to clear the data for the line segment and take a fresh set of data.

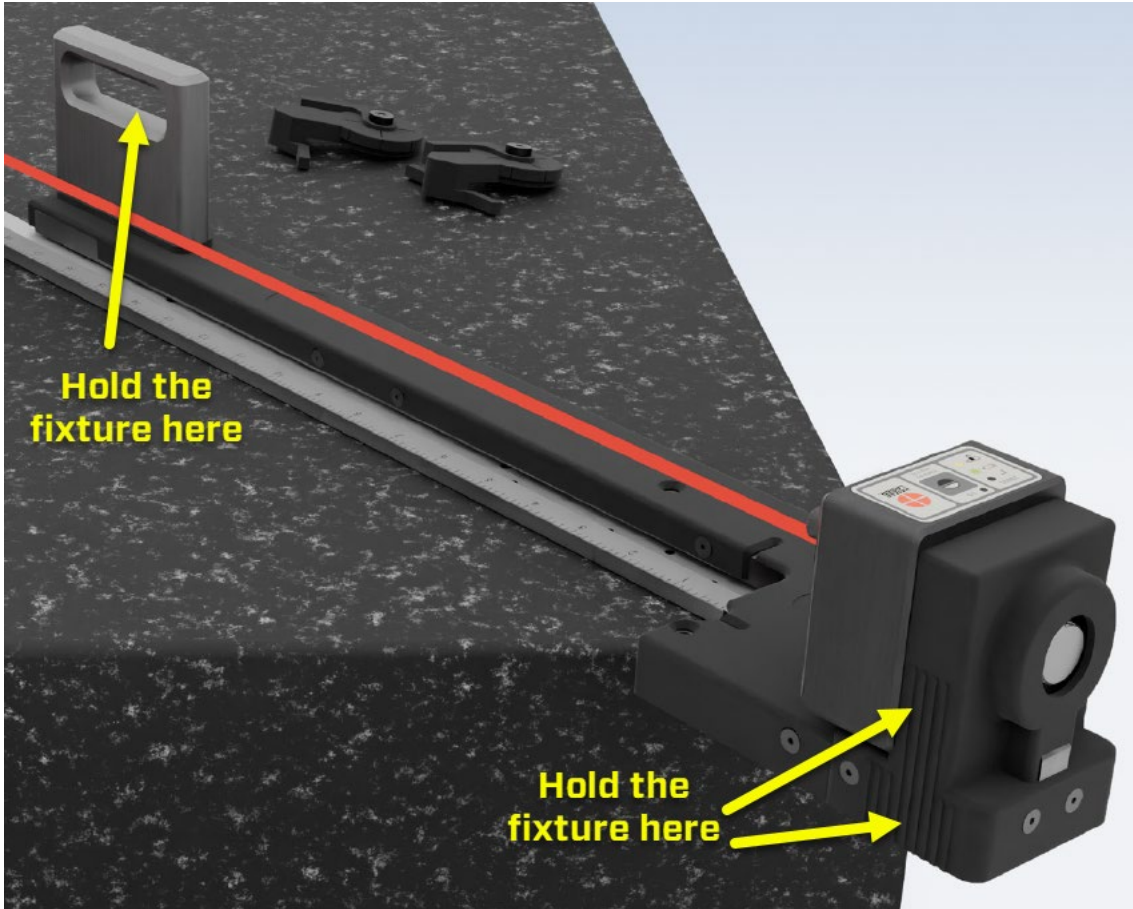

Figure 12 - A-703SP-LM Laser Mounting Fixture Handholds

A-1297-SP High Accuracy, Flatness Measuring Base for T-1297 Target

A-1297-SP is used to mount the T-1297 Target (see **Figure 13**) to measure the flatness of the plate for measuring:

- Flatness measurements of surfaces.
- Flatness, straightness & squareness measurements of machine tool axes.

The A-1297-SP has a measuring foot that is .375 in. in diameter and this is the minimum increment that you can move the target for the measurements. Insert the T-1297 Target into the .4995 in. (12.7 mm) mounting hole, making sure to insert the alignment pin (see **Figure 13** and Step 4, starting on Page 45) into the smaller hole below the main hole. Make sure to tighten very tightly to ensure a rigid mount and repeatability issues.



Figure 13 - A-1297-SP High Accuracy, Flatness Measuring Base for T-1297 Target

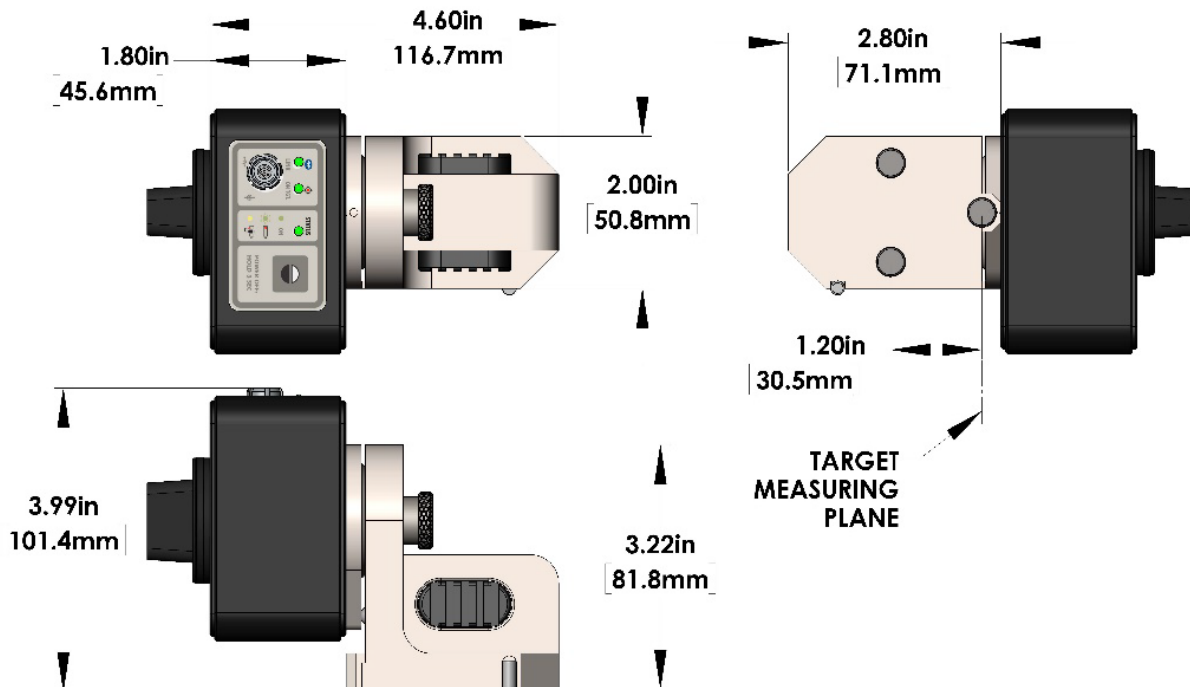

Figure 14 - A-1297-SP Measuring Base - Dimensions

A-703SP-SE-A/B/C/D Target Straight-Edges and Rulers

Used with the A-703SP-LM Surface-Plate Mounting Fixture (see **Figure 8**) as a guide for the T-1297 Target to take flatness data for each line segment. They come in the following sizes:

- A-703SP-SE-A Target Straight-Edge and Ruler – 18 in. (457 mm)
- A-703SP-SE-B Target Straight-Edge and Ruler – 26 in. (660 mm)
- A-703SP-SE-C Target Straight-Edge and Ruler – 36 in. (914 mm)
- A-703SP-SE-D Target Straight-Edge and Ruler – 54 in. (1,373 mm)
- A-703SP-SE-E Target Straight-Edge and Ruler – 72 in. (1,829 mm)
- A-703SP-SE-F Target Straight-Edge and Ruler – 12 in. (305 mm)
- A-703SP-SE-D-EXT-A 18 in. (457 mm) Target Straight-Edge Extension and Ruler for 72-90 in. (1.8-2.3 m) lengths
- A-703SP-SE-D-EXT-B 18 in. (457 mm) Target Straight-Edge Extension and Ruler for 90-108 in. (2.3-2.7 m) lengths
- A-703SP-SE-D-EXT-C 18 in. (457 mm) Target Straight-Edge Extension and Ruler for 108-126 in. (2.7-3.2 m) lengths

For the 18-in add-on extensions, they must be assembled as shown in **Figure 15** To assemble the pieces:

1. Screw in the mounting screws but leave them loose.
2. Place the scale side edge of each straightedge down on the surface plate to align the straightedge pieces and make them straight.
3. Tighten the screws very tightly to ensure the straightedge stays straight.
4. Add the GPR-RB Reinforcement Bar to the top of the straightedge to make it rigid. Do NOT overtighten the bolts. Just a light tightening is fine. Over-tightening may cause the straightedge to bow up, which can cause the rubber feet to fail to make contact with the surface plate.

Note: If the rubber pads come off, use Loctite 496 Glue to reinstall them. Contact the sales office to get replacement rubber pads.

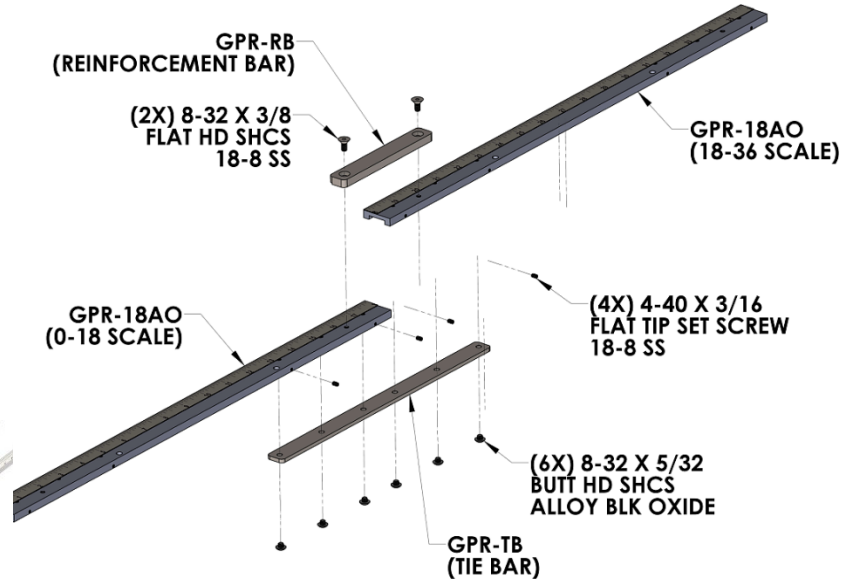

Figure 15 - A-703SP-SE-EXT-A/B Target Straight-Edge



Figure 16 - A-703SP-SE-A/B/C/D Target Straight-Edges and Rulers

Selecting Straightedge Length

To select the length of the straightedge, use the table below to see which length to use. It is recommended that you select the straight-edge length that is less than 1.5 times the Grid Line Dimension, which ensures the best stability for the bar. For example, for the 18x18 plate, use the 18 in. straightedge for the sides and midpoint segments and the 36 in. straightedge for the diagonals.

Note – For situations where the laser fixture location has to be reversed, such as when the plate is against a wall, then the straightedge length needs to be less than the line length minus 2x the border width.

We recommend that you assemble the longer straightedges (see above) before starting the alignment checks. This allows you to easily swap in a longer or shorter bar as needed for each segment and speeds up the calibration process.

Here are some definitions for the table:

- *Plate Size* – this is the nominal dimensions of the plate from edge to edge.
- *Diag Bar Increments* – this is the total number of 18-in. increments needed for the straightedge.
- *Longest Bar* – this is the longest bar that is needed for the longest line segment (the diagonal).
- *Grid Line Dimensions* – this is the length of the plate side minus 2 x the border width. This represents the total length needed for the measurements for that line segment.
- *Diag Angle* – this is the angle of the diagonal relative to the edges and is generally not needed for a measurement but is for informational purposes.

Note - if you use a straightedge that is too long for the plate, it will not be stable and may lead to errors.

Plate Size			Diag Bar Increments	Longest Bar	Grid Line Dimensions [(Length/Width - (Border*2))]			
Width	Length	Diag			Width	Length	Diag	Diag Angle
12	12	17.0	0	18.0	9.0	9.0	12.7	45.0
12	18	21.6	0	18.0	9.0	15.0	17.5	31.0
18	18	25.5	0	26.0	15.0	15.0	21.2	45.0
18	24	30.0	0	36.0	15.0	21.0	25.8	35.5
24	24	33.9	0	36.0	21.0	21.0	29.7	45.0
24	36	43.3	0	54.0	21.0	33.0	39.1	32.5
24	48	53.7	0	54.0	21.0	45.0	49.7	25.0
36	36	50.9	0	54.0	33.0	33.0	46.7	45.0
36	48	60.0	0	72.0	33.0	45.0	55.8	36.3
36	60	70.0	0	72.0	33.0	57.0	65.9	30.1
36	72	80.5	0	90.0	33.0	69.0	76.5	25.6
48	48	67.9	0	72.0	45.0	45.0	63.6	45.0
48	60	76.8	1	90.0	45.0	57.0	72.6	38.3
48	72	86.5	1	90.0	45.0	69.0	82.4	33.1
48	96	107.3	2	108.0	45.0	93.0	103.3	25.8
48	120	129.2	3*	144.0	45.0	117.0	125.4	21.0
60	120	134.2	3*	144.0	57.0	117.0	130.1	26.0
72	96	120.0	2	126.0	69.0	93.0	115.8	36.6
72	144	161.0	3*	162.0	69.0	141.0	157.0	26.1

* Requires customized extensions that are not part of the optional extensions.

A-703SP-SE-CLT Corner-Locating Tools

To set the straight edges at the proper spacing from the edge of the plate, we supply a set of A-703SP-SE-CLT corner locating tools to aid in the setup. They come in 3 sizes:

A-703SP-SE-CLT-1.5 Corner & Midpoint Straight-Edge Locating Tool - Set of 2 for 1.5 in. border - included

A-703SP-SE-CLT-2.0 Corner & Midpoint Straight-Edge Locating Tool - Set of 2 for 2.0 in. border - included

A-703SP-SE-CLT-2.5 Corner & Midpoint Straight-Edge Locating Tool - Set of 2 for 2.5 in. border - optional

Select the right tool to match the desired border width. You must also set the border width in Plane6 Software Step 1 (see Page 34).

There are two types of locating tools:

1. The first type is used on the laser end of the straight edge, and
2. The second type is used on the target end of the scale.

The laser side tool has a rotary edge locator that is used to set the end of the straight edge at the correct dimension from the plate. You need to match the end of the rotary piece with the zero point on the straight edge.

Note – you always put the scale side of the straightedge touching the corner-locating tool – see the images to the right.

*However, if you click **Reverse Direction** in Step 2 and are using the A-703SP-LM-M Mirrored Fixture, then place the straightedge's non-scale side against the corner locating tool.*

The target-side tool does not have the rotary edge-setting tool.

Note - When the straight edge is positioned in the correct location, you must remove the corner locating tools by sliding or peeling them off the plate. Try not to move the straightedge when removing them.

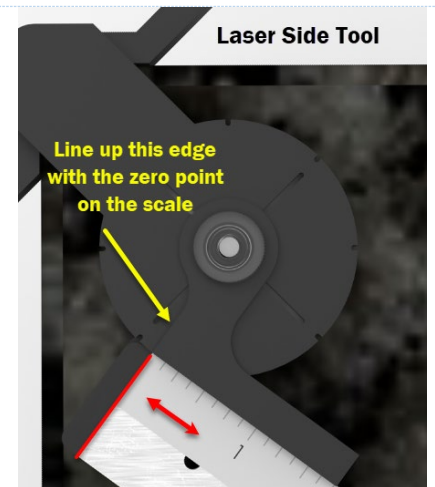

Normal Setup for AG

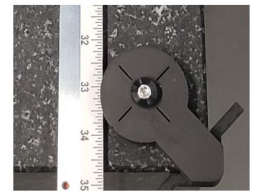

Reverse Setup for AG



A-808-1297-DM Target Calibration Fixture

The A-808-1297-DM is a calibration fixture to calibrate the T-1297 Target. The calibration factors are stored in Plane6 Software and can be recalibrated using the A-808 fixture. See Appendix D - How to Calibrate the T-1297 Target for more details.

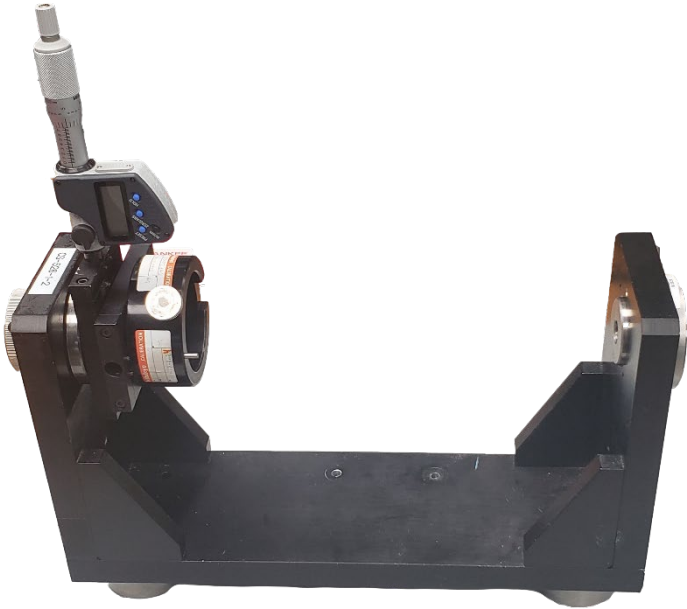

Figure 17 - A-808-1297-DM

Preparing for an Alignment

There are several preparations that need to be made before beginning a measurement or alignment process. Ensure that accurate records are kept for all procedures.

System Warmup Period

IMPORTANT!

We recommend that the user let the L-703S Laser and T-1297 Target warm up for at least 30 minutes for the lower-accuracy plate grades and for 45-60 minutes for the high-accuracy plate grades (see table below). To warm it up, simply turn them on and let them run for the recommended time. The warmup period allows the internal mounting hardware to thermally grow to a stable state, which reduces the variability in the measurement.

It is also essential to let the A-703SP-LM Surface Plate Fixture and A-1297-SP Target Base acclimate to ambient temperature (“soaking”) because, as the fixture grows thermally, it can cause the laser beam to move significantly, increasing uncertainty. For a few degrees difference, we recommend 30 minutes of “soaking” time. For greater temperature differentials, here are the recommended “soaking” times for the A-703SP-LM:

	Soaking Times (minutes)		
	Grade B	Grade A	Grade AA
A-703SP-LM Laser Fixture	30	45	60
Fixture Temp < 5° F from Ambient	30-45	45-60	60
Fixture Temp 5-10° F from Ambient	45-60	60-90	120-150
Fixture Temp >10° F from Ambient	60-90	90-120	150-300

Cleaning the Plate

For accurate calibration results, it is highly important to clean the surface plate prior to starting the calibration check. Use approved surface plate cleaners and cloths to remove all dust and dirt (see **Figure 18** Relative Particle Sizes).

For example, if you are trying to calibrate a 36x36 in. plate to a Grade A spec, the flatness requirement is 300 μin. or 8 μm (microns). As you can see a few grains of dust (4 microns) on your plate and this eats up half of the Grade A tolerance, which can significantly impact the flatness data! Run your hand over the plate to feel for dust and make sure it’s ready to check the flatness. We also recommend using a cloth to wipe each measurement line before taking the data – you can even use your hand. Also, frequent wiping of the bottom of the target base is important to keep dust off of it.

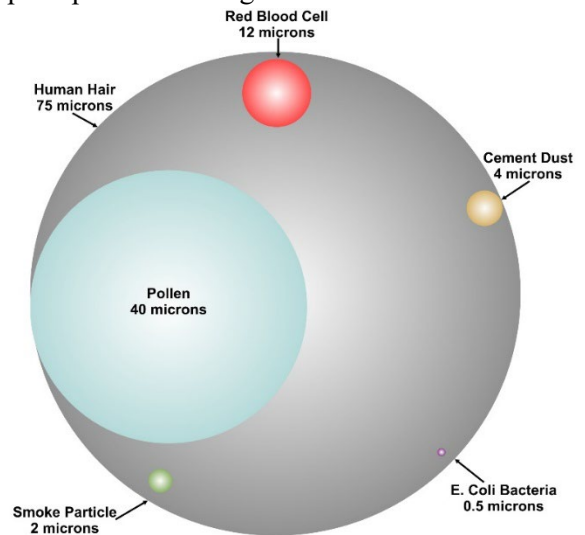

Figure 18 - Relative Particle Sizes

Maintenance and Cleaning of L-703SP & T-1297

The windows on the T-1297 target should be clean and free from dirt, thumbprints, and other smudges. Clean the window with alcohol wipes or a Q-tip soaked in alcohol. Always wipe in the same direction. Do **not** wipe back and forth.

The same applies to the L-703SP Laser Window. If you see a bright reflection on the lens window on the laser (see **Figure 19**), which means it is contaminated and needs to be cleaned.

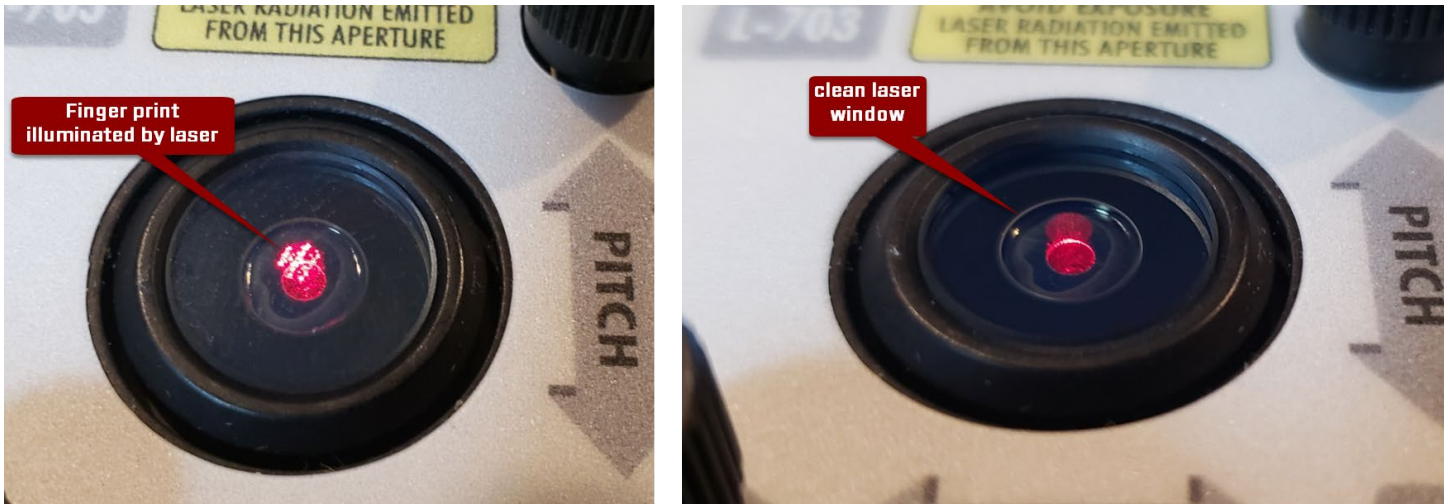
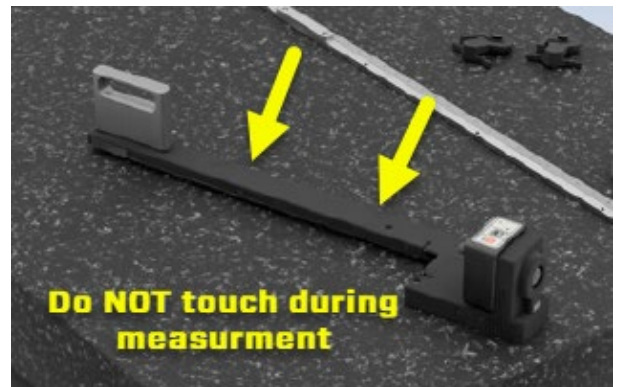

Figure 19 - Dirty vs. Clean Laser Window Example

Important Tips for Taking Data with the L-703SP

1. **Do Not Touch L-703S-LM During Measurement** – After positioning the laser fixture and straightedge, it is VERY important to NOT touch the laser fixture during the measurement of any of the lines. This can cause the fixture to bend or slide, which can move the laser beam and introduce additional uncertainty into the measurement.
2. **Wear Gloves for AA-Grade Plates** – We recommend wearing thin gloves to insulate the heat from your hands when handling the L-703SP-LM Laser Fixture when measuring AA-grade plates. If you touch the uncovered bottom of the fixture, your hand will warm the metal, causing it to grow thermally, which will happen remarkably fast – in 1 second! This can result in a significant change in the measurement value when the target is located several feet away.



3. Hold the L-703SP-LM Fixture at the Base – It is best practice to hold the L-703S-LM Fixture at the plastic base of the upright and the steel handle. Do not hold it from the bottom of the fixture, where the metal is exposed. See the image. This will limit the amount of bending in the fixture when moving from line to line and the fixture will stabilize faster.
4. Pause before Taking Data - We recommend waiting between 30-120 seconds (varies by plate grade – see page 10 for more details) after setting down the fixture before taking data for a new measurement line. This gives the fixture time to settle down and stabilize.
5. Wipe the Surface before Taking Data for Each Line Segment – Use the plate cleaning cloth to wipe the line segment before taking data for the line. This will capture any dust that has fallen on the plate while you have been taking data for the other lines.

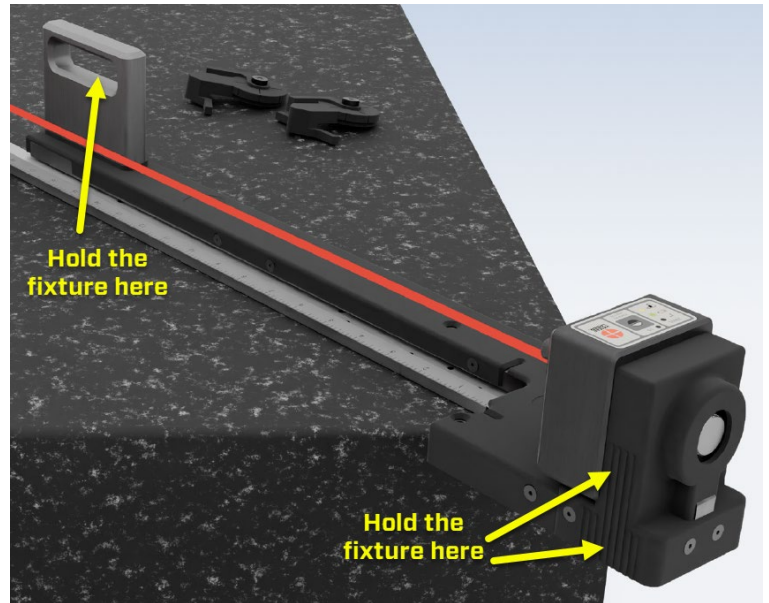

S-1409 Plane6 Surface Plate Calibration Software - System Requirements

- Physical memory (RAM): 8 GB recommended for Win10 & 11
- Processor: Intel Pentium4 or later version or AMD equivalent, 1.3 GHz minimum speed
- Available Hard Drive space: 20 GB minimum
- Video Resolution: 1366 x 768 minimum (32-bit color) with hardware acceleration and dedicated video memory.
- Windows 10/11 professional editions.

The following Microsoft Windows operating systems have *not* been tested and are not supported with Plane6:

- Windows 7 (All versions)
- Windows 8 (All versions)
- Windows XP (All versions)

Before installing Plane6, ensure that your computer has the latest Windows Service Pack and critical updates. To find security updates, visit www.windowsupdates.com.

In addition, to read this Plane6 Surface Plate Calibration manual PDF file on your laptop, it is necessary to install Adobe Reader/Acrobat or an equivalent PDF reader program. Adobe Reader can be downloaded for free from: [Download Adobe Acrobat Reader: Free PDF viewer](#).

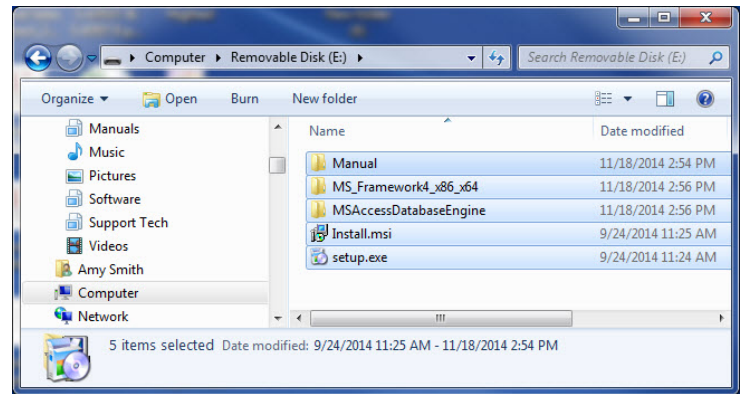

Installing Plane6

1. Insert the USB flash drive provided into the USB port on the laptop or tablet PC. Or insert the CD into the CD drive.
2. If your system is configured to do so, the AutoPlay window displays. Click **Open folder to view files**.
3. If the AutoPlay window does not display, click **Start>Run**. Click **Browse>My Computer** and select the USB flash drive.
Note: *.NET 4.0 framework must be installed– see Page 70 if you are unsure if this has been installed.*
For CDs, Start>Run. Click **Browse>My Computer** and select the CD ROM drive.
4. Click **setup.exe** to begin the Plane6 installation.



Getting Started with Plane6

Hamar Product Registration

After a Hamar product is installed and when the program is run for the first time, the user is prompted to enter the Product Registration Code (see **Figure 20**). To obtain the Product Registration Code, send the **PC ID** Code (16 digits) automatically generated and displayed on the screen to Hamar Laser Support (Support@hamarlaser.com). A Hamar representative will issue a Product Registration Code via email to complete the registration process (see **Figure 21**).

Enter the Product Registration Code and click **Register Product**. The product is now registered.



Figure 20 - Product Registration Screen

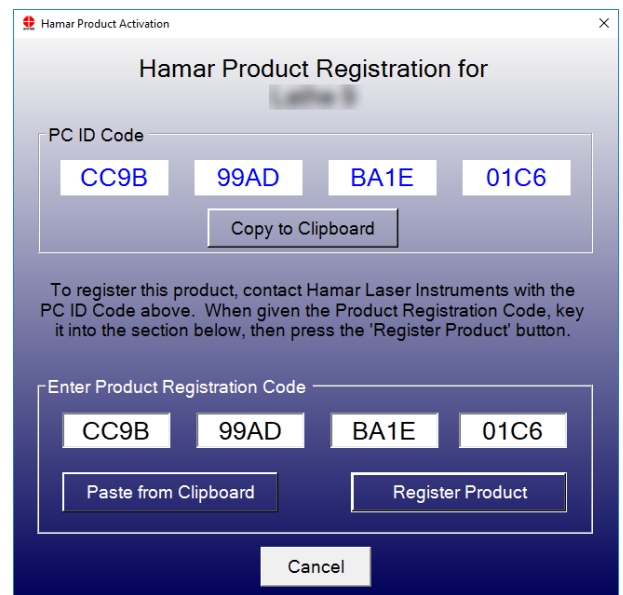



Figure 21 - Enter Product Registration Code

To begin using Plane6, double-click the Plane6 icon on your desktop or select the program from the Windows Start Menu. The initialization screen displays, providing the number of the current software version.

Authorizing Lapping Line View™

Lapping Line View is an optional feature that must be authorized before use. Please contact us at sales@hamarlaser.com (203-730-4600 x114) to request a quotation. Once the order has been placed, you will receive a Product Key code.

How to Authorize Line View

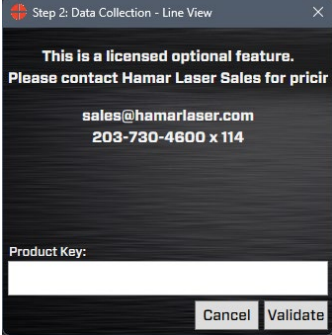
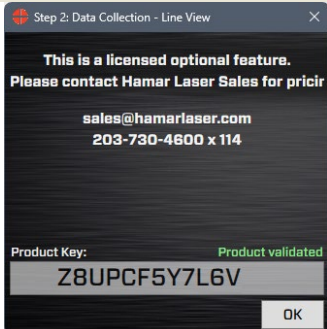
Click on the Lapping Line View (Line) Tab	
Enter the Product Key and click on <i>Validate</i> :	
You will see “Product Validated” and after clicking OK, you’ll see the new Line View enabled and ready for use.	

Creating a New Project File or Opening an Existing Project File

When creating a new project, Plane6 will create a folder with the filename entered here. It will then create a project file in the folder with a time stamp of when it was created. After saving a project, you can open the project file and save a new file for this project, which will save the information entered in Step 1 but will clear the data recorded in Step 2.

Project Selection Screen:

When Plane6 opens, the **Project Selection** screen displays the following:

Recent Projects – This will list the most recent projects that were saved.

Open Project – select one of the recently saved projects and click **Open Project** to open the project. You can also double-click the filename to open it.

New Project – click here to enter a filename and create a new project *folder* and project *filename* within the folder.

Browse – Click here to open the Windows File Open dialog box and browse for a saved file, either from another folder or from a USB drive.

Exit – this closes the window.

Note: This screen can also be accessed by clicking **Open Project** from the **File** menu.

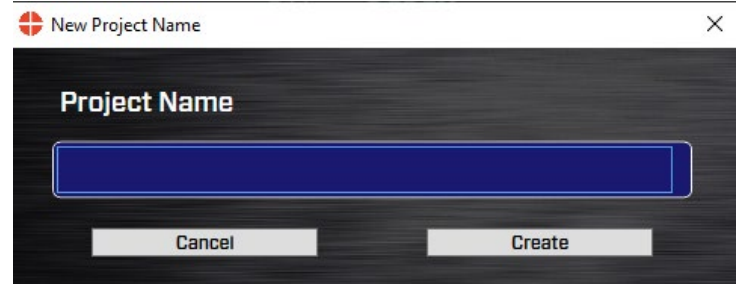
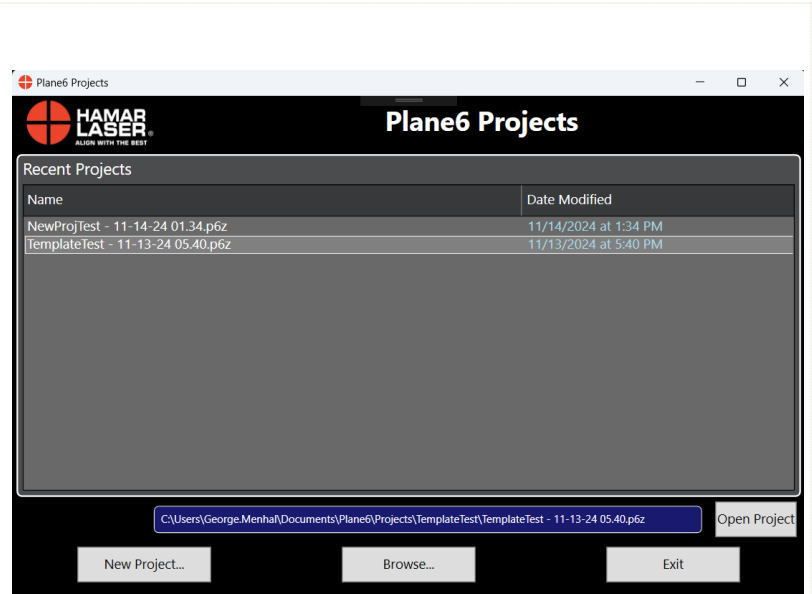

File Menu

New Project – see above

Open Existing Project – same as above

Save File – saves the project.

Save New File for Existing Project –allows you to save a file of the same project name (stored in the same folder) to the current Windows folder. It gives you the option to keep the saved data or clear it. If you are doing a second calibration check for plate, then click on *Erase Saved Data*

Save As New Project –allows you to save a project file of a *new* name to a *new* folder. It keeps only the information entered in Step 1. All the data from Step 2 is erased.

Exit – exits Plane6, and if the project has not been saved, you will be prompted to save it.

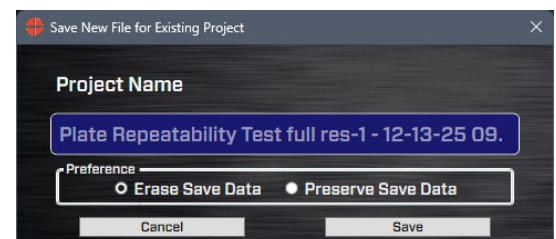
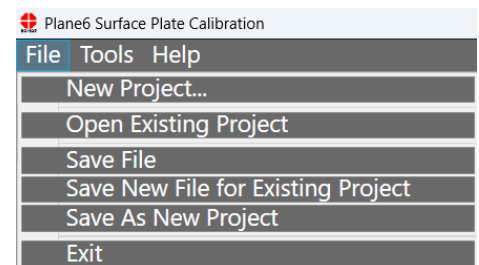

File Location

Files are saved in the *Documents/Plane6/Projects* folder.

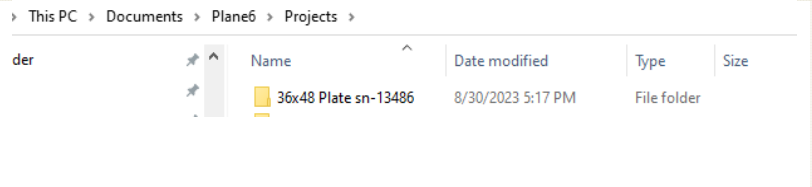

Each project is saved into a dedicated folder in the Projects folder that you specified in the New File dialog box.

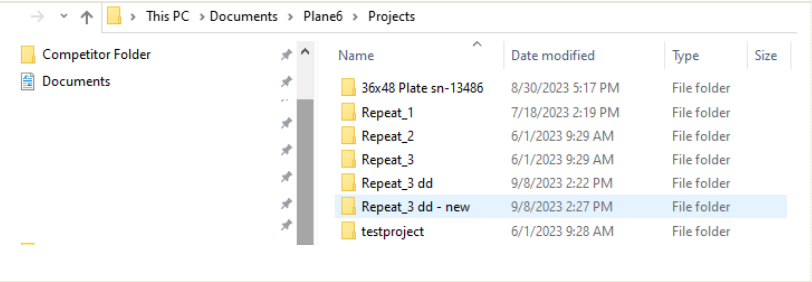

File Structure

In each Plane6 folder, there are 2 data files.

- The *****.p6z** file contains all the data taken during the session.
- The ***.p6z.backup*** are backup files recorded during each session you save data.

The data format for these files is XML but it can be exported to a CSV file by clicking on the Tools menu. The file can be opened in Notepad and viewed there. All data is recorded in microns. Divide all values by 1000 to get millimeters.

Warning! Do not delete or modify the P6z files in these folders as Plane6 will be unable to open the project.

Converting Raw Data Values in CSV files to Inches or Millimeters

The values stored in the CSV file correspond to the units chosen in Preferences, either μin or μm .

- To get inches, divide the microinch value by 1,000,000:
- To get mm's, divide the micron value by 1000

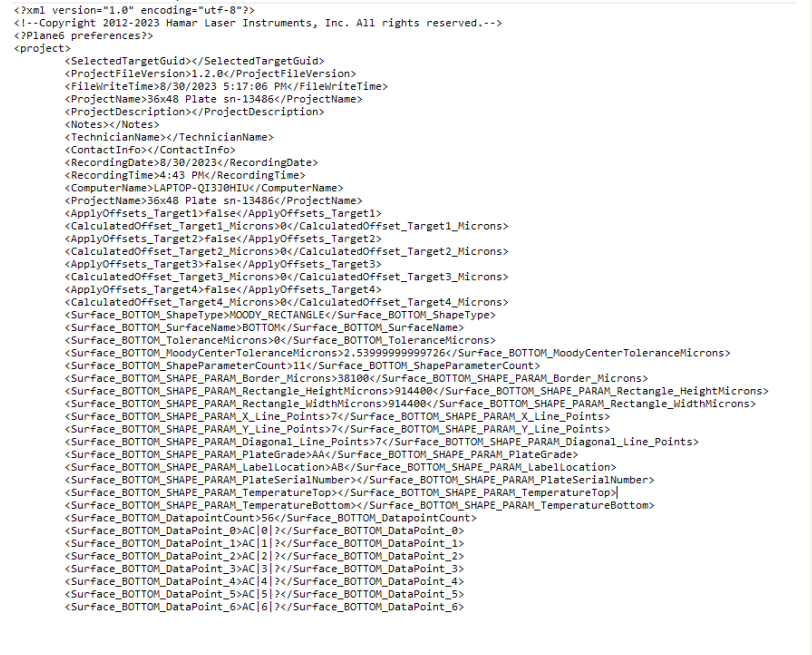
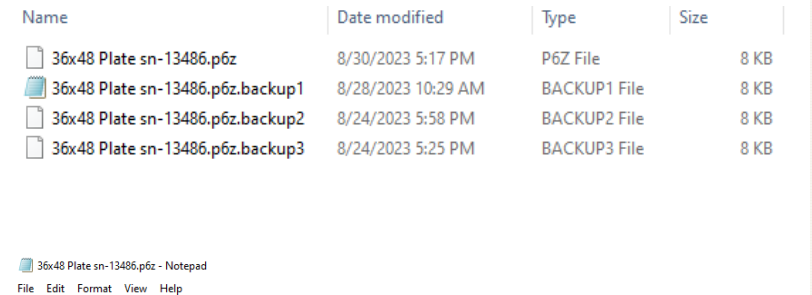

Plane6 Software – Summary of Main Screens

Step 1: Set Up Plane6

Enter the horizontal and vertical dimensions of the plate and the border width from the edge of the plate to the measuring line. Then select the number of points you want to measure for the horizontal, vertical and diagonal lines. Next, select the plate grade, enter the plate serial number and top and bottom temperature (if measured).

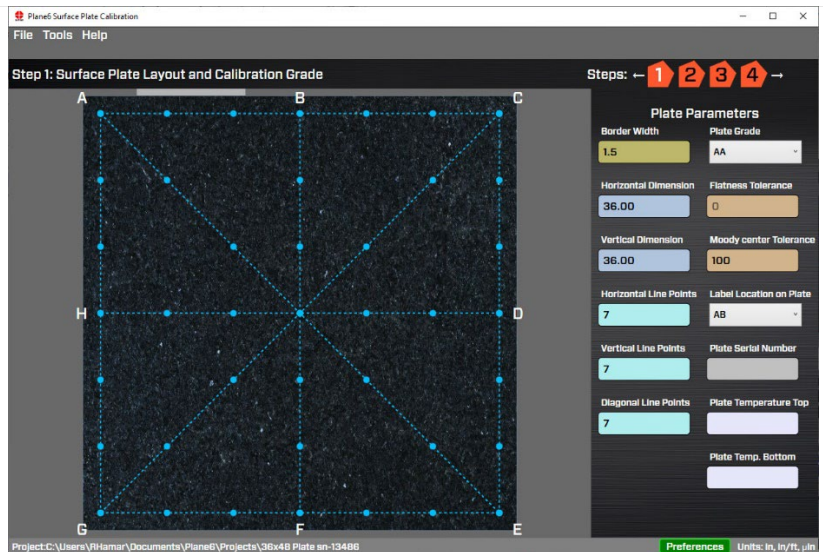

Figure 22 - Plane6 - Step 1 Dimensions & Tolerances

Step 2: Data Collection – Plate View

There are 2 data collection screens: *Plate View* and *Line View*.

Plate View - This is the main data recording screen. It features a 2-axis, real-time data display, with a graphical layout for the plate, measurement points, and distances. It guides the user through the sequence of data taking for the 8 line segments in the Moody Method for calibrating surface plates.

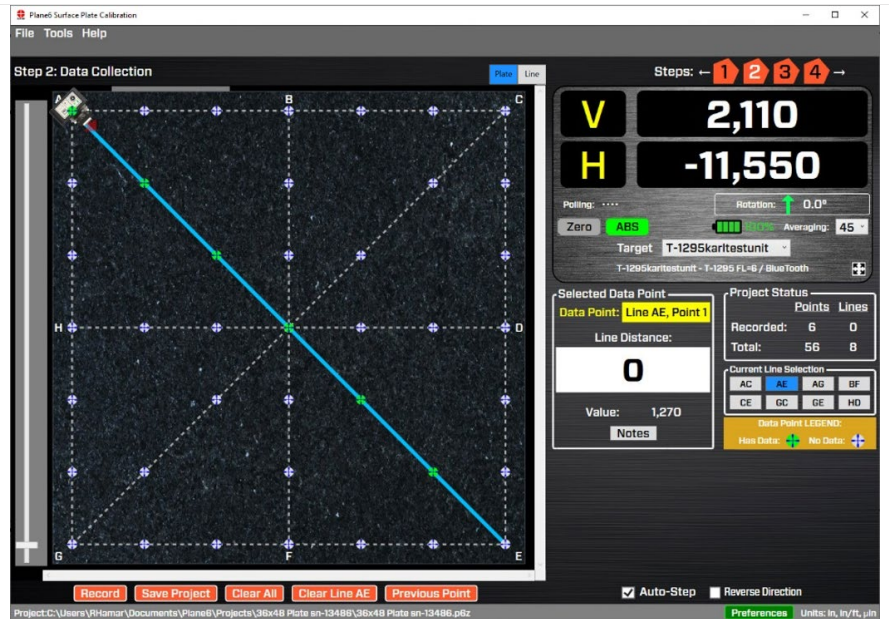

Figure 23 - Plane6 - Step 2: Data Collection

Step 2 Data Collection – Line View - Optional

For situations where the plate has failed calibration and needs to be resurfaced (lapped), a second data-taking method, called Line View, has been developed. It is an optional feature and requires an additional license (*on page 2222*).

Just as with *Plate View*, *Line View* features a 2-axis, real-time data display and enables the recording of line flatness data for each of the 8 individual line segments in the Moody Method and features the ability to chart the flatness of up to 5 line revisions at once.



Step 3: Results -

After recording the data, click on Step 3 to view the overall flatness results and whether it is in tolerance or out. You can also view the data for each line segment and a 3d graph of the alignment.

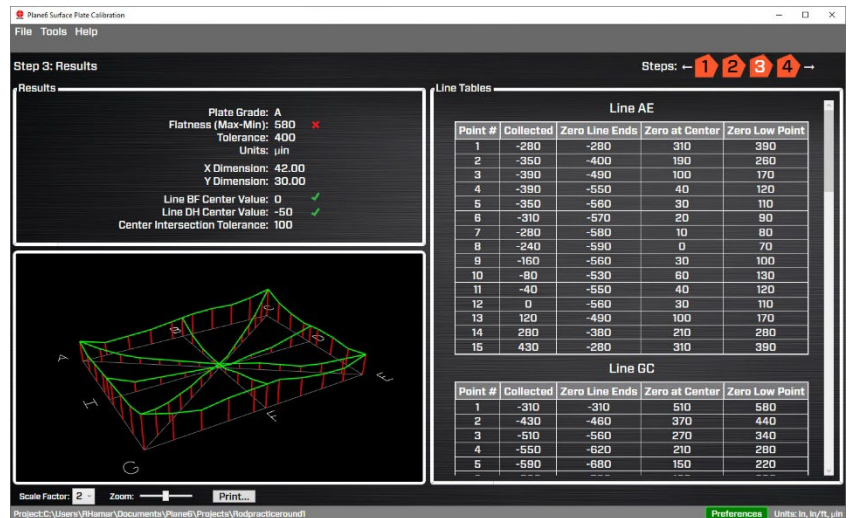

Figure 24 - Plane6 - Step 3: Results

Step 4: 3D Graph

In Step 4, you can view an adjustable, 3D graph of the alignment. Rotate and zoom in to see the results for each line segment plotted on the graph.

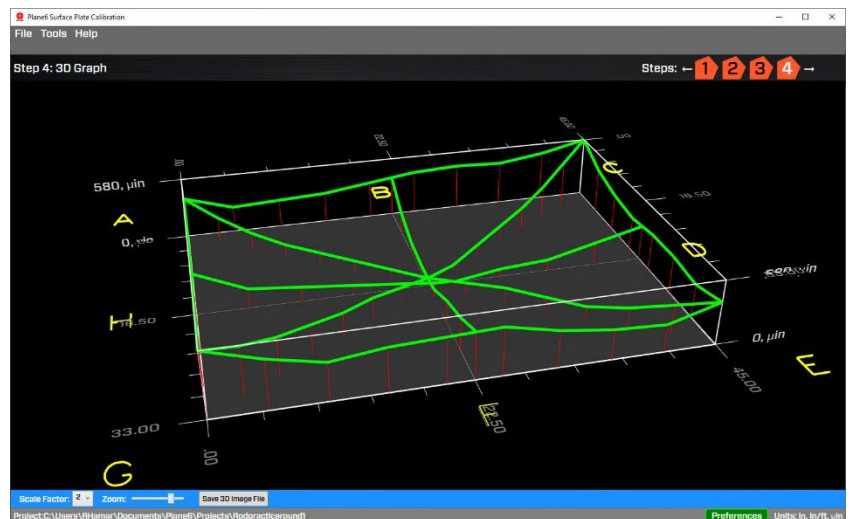

Figure 25 - Plane6 - Step 4: 3D Graph

Plane6 Screens - File Menus

File Menu

New Project – see above

Open Existing Project – same as above

Save File – saves the project.

Save New File for Existing Project –allows you to save a project file of the same project name to the current working directory. It keeps only the information entered in Step 1. All the data from Step 2 is erased.

Save As New Project –allows you to save a project file of a new name to a new folder. It keeps only the information entered in Step 1. All the data from Step 2 is erased.

Exit – exits Plane6 and if the project has not been saved, it will prompt you to save it.

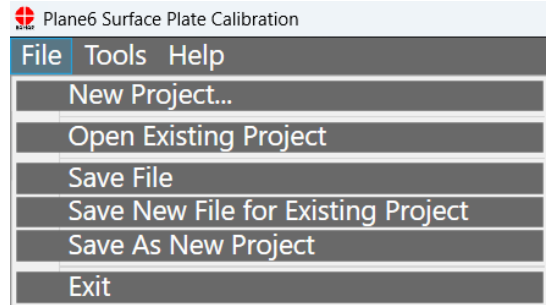

The Tools Menu

Preferences - Opens the Preferences window to change units, resolution, decimals, target type, etc. See more details below.

Export Line Data to CSV File – Exports data in a CSV format to easy importing into Excel. The CSV file is saved in the same folder as the main project file. After clicking on this item, you will be prompted to enter a filename for the project. It uses the existing filename by default.

Note – if you previously exported to a CSV file from another project, you will need to change the directory to match the current Project Filename when you export to a new CSV file.

After saving the file, use Excel to open the file and the data will be in there. The file contains the raw data from the table and does not display the results.

Show Line Dimensions – Opens a window showing the number of measurement points, the line distance for each point on the line segment for the horizontal, vertical and diagonal lines.

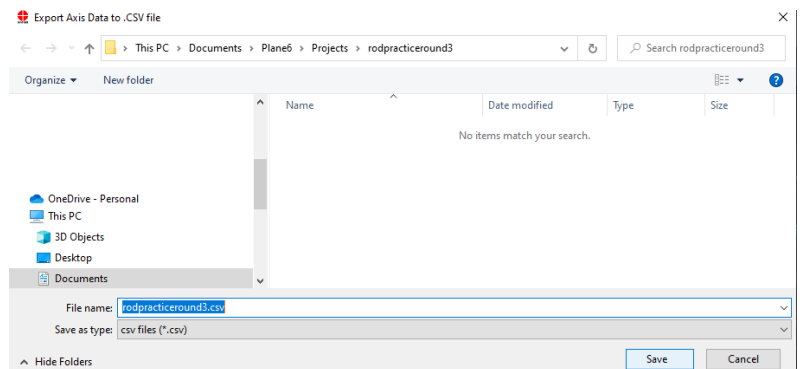
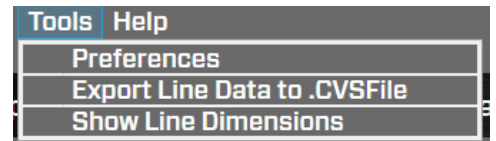

Horizontal Lines		Vertical Lines		Diagonal Lines	
Point #	Distance	Point #	Distance	Point #	Distance
1	0	1	0	1	0
2	5 1/2	2	5 1/2	2	7 3/4
3	11	3	11	3	15 1/2
4	16 1/2	4	16 1/2	4	23 1/4
5	22	5	22	5	31
6	27 1/2	6	27 1/2	6	39
7	33	7	33	7	46 3/4

Figure 26 - Plane6 Show Line Dimensions window

The Help Menu

View Manual - Opens a PDF of the manual.

About This Program - Usual info about the program.



Navigating Plane6 with the Status Bar

Software Steps

In the upper right part of all the screens is the Navigation Bar. It lists the number of steps in the software along with arrows to move to the left or the right. You can either click the arrow to move back or forward to the previous or next step or click on any step to go straight to the page.



Plane6 Screens - Preferences

Click **Preferences** to open a window to change Plane6 settings. You can also click on the Preferences button in the lower right side of each screen in Plane6.

Note: If you are installing the software yourself, you will need to go to **Enter Target Info** (see **Page 32**) and follow the procedure to enter the target serial number and calibration factors.

Navigation – Use the Navigation button to go to a particular section in Preferences. You can also use the scroll bar to move the scrollable section up and down.

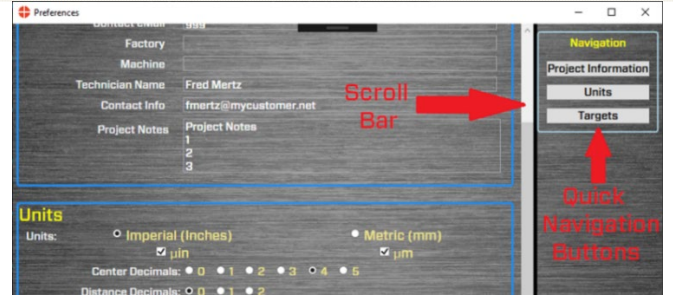

Project Information

Enter a project description, company contact information and notes that will be displayed in the reports here. You can also add a custom logo to the report. Click on the ellipse (3 dots) to the right of *Company Logo Filename* to upload the image into Plane6.

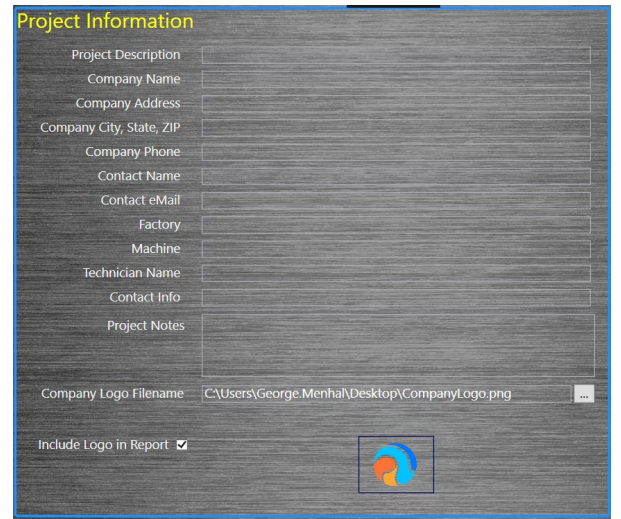

Units

Select **Imperial (in.)** or **Metric (mm)** and units for the project. Check on the μ in checkbox to see the units in *microinches* (e.g. 1,000 instead of .00100 in.), or μ m to see the units in *microns* (e.g. 10 instead of 0.0100 mm).

If you prefer normal digits (i.e. .0001), then select the number of digits to show in the display.

For the line dimensions, you can also select the fraction rounding increment and Plane6 will round the fraction up or down to the selected value. For example, if "1/4" is selected and the next point dimension is 5 3/16, then Plane6 will display 5 1/4 as the dimension for the next point. You can also choose a decimal in the display.

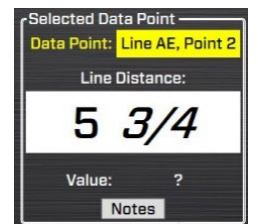
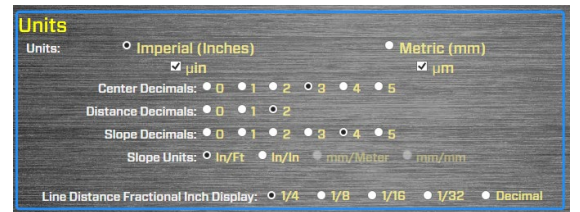

Targets

Target settings

Averaging – This controls the amount of sampling the software does for both the live data display and for recording each value. If the Averaging value is set to 40, then Plan6 will record 40 values and average them, applying a spike filter to reduce noise in the measurement. The data updates at a rate of 14-15 readings per second, so for 40 samples, the data display should update in about 3 seconds.

Spike Filter – This is the number of data points that are filtered out of a set of recorded data after sorting them from high to low. The default is 40%, or $\pm 20\%$ off each end of the sorted data, meaning the highest 20% of the values and the lowest 20% of the values are removed. Then, the rest of the data points are averaged into a single recorded value.

Vertical & Horizontal Tolerance (\pm) – this is a display tolerance for Step 2 that changes the display background color to orange if these tolerances are exceeded. The recommended values (default) are:

Imperial:

Vertical: $\pm .0075$ in. ($\pm 7,500$ $\mu\text{in.}$)

Horizontal: $\pm .010$ in. ($\pm 10,000$ $\mu\text{in.}$)

Metric:

Vertical: ± 0.19 mm (190 μm)

Horizontal: ± 0.25 mm (250 μm)

If the display values are higher than these, the values will start to become slightly less accurate. If you are working on a B-grade plate, then these values can be exceeded without an issue.

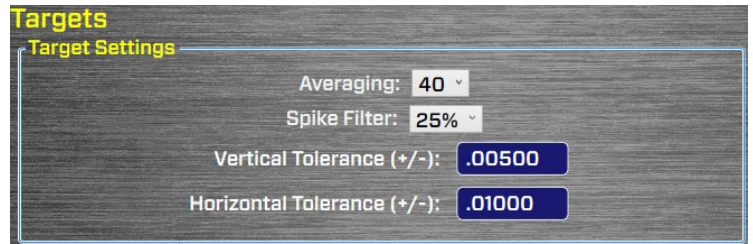

Calculation of 1 data point with 10 Samples Using Spike Filter

40% Filter										
Num Points to delete (.4*10)	4									
Point	1	2	3	4	5	6	7	8	9	10
Recorded Values	210	250	220	200	210	250	210	220	210	240
Sort Low to High	200	210	210	210	210	220	220	240	250	250
Delete 2 hi & 2 Lo Points	200	210	210	210	210	220	220	240	250	250
Ave the remaining values:	218.33									
Rounded Recorded Value	220									

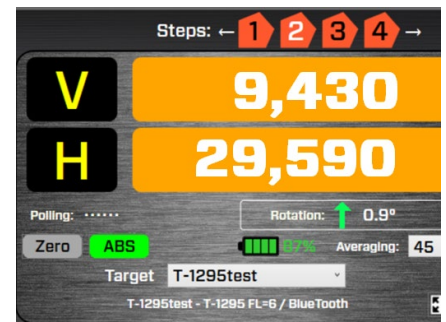

Defined Targets

This is a list of T-1297 Targets (or other similar targets) that have been set up in Plane6.

This list will show up in the dropdown menu in Step 2.

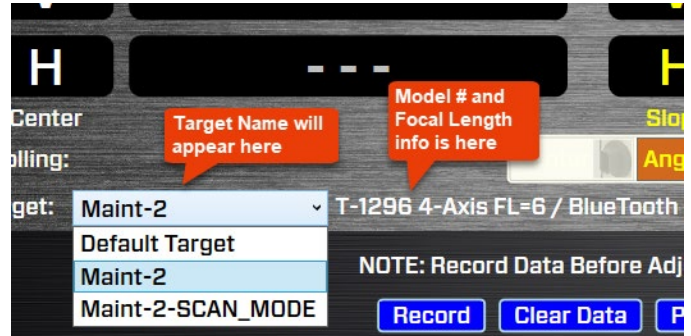
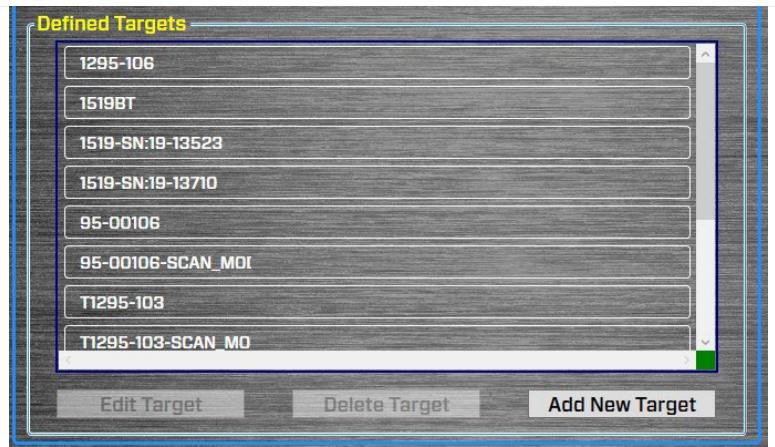

Targets – Setup Procedure

When you buy a new system and laptop from HLI, the target setup is already pre-configured into Plane 6. However, if you are installing Plane6 on your laptop, then you must follow this procedure to set up the target.

1. Click the **Target** button or scroll to the bottom of the screen.

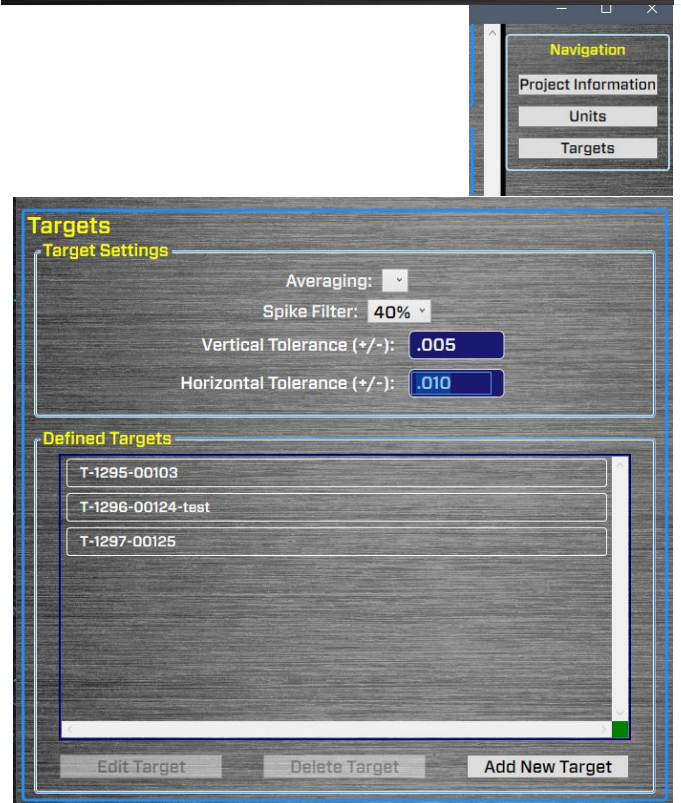

2. Click **Add New Target** to specify and set up a target type and computer interface if needed. There will be a dropdown list of target types supported by Plane6.

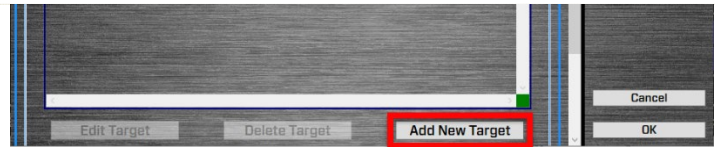

3. **Select Target Type – T-1297 Targets 3-Axis Mode**

To choose the T-1297 targets, select T-1297 (3 Axis Mode).



4. **Target Name.** Enter a “nick name” for the target. This name will show up in the Target area on the data displays. The Plane6 display area automatically displays the target part number and serial number. We suggest using the target’s type and the last 4 digits of its serial number for the name, especially if there are many targets set up.

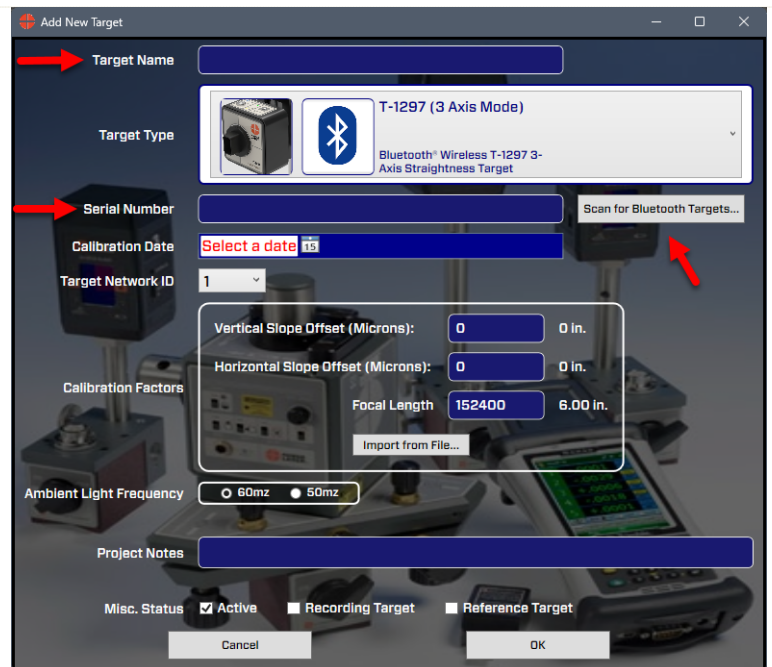
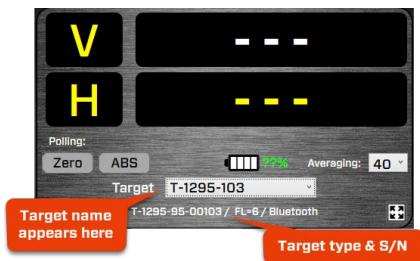

5. **Serial Number and Calibration Date** – enter the serial number and calibration date (supplied with the system)

6. **Scan for Bluetooth Targets** - You will need to pair the targets with the laptop - see Page 7 How to Pair the T-1297 Target’s Bluetooth to a PC.

After pairing, click on **Scan for Bluetooth Targets** to see if your target has been paired with your PC. Paired targets will display in the window (shown right). If your target is not displayed, it will need to be paired.

If it shows up in the list, then click on the serial number and click on **Select Serial Number XXXX** to select the paired target. Then click on **Close Window**.

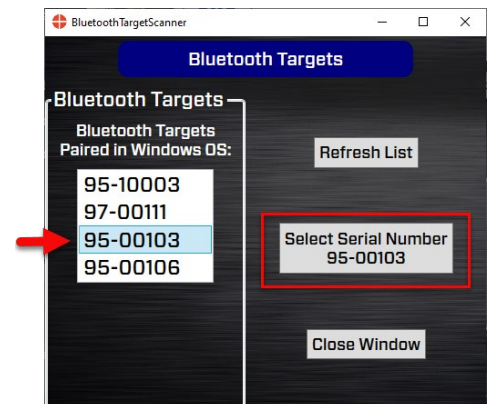

7. Target Network ID

This is needed for our A-1519/1520 Scanning targets and is not used in this application.

8. **Calibration Factors - Vertical and Horizontal Center** . These are calibration factors for the target. There are separate factors for the + and – areas on the PSD. You can either enter them from the calibration sheet supplied by HLI or click on *Import from File* and upload them from a USB drive or CD ROM.

Note - If you have purchased the A-808-1297-DM calibration fixture, then you can generate your own calibration factors. See T-1295, T-1296 & T-1297 Calibration Manual for a detailed procedure.

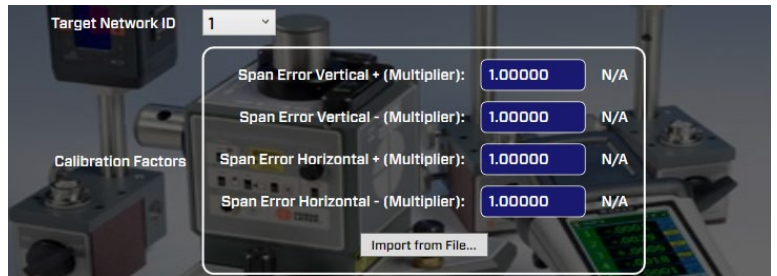

9. **Ambient Light Frequency** – The T-1297 Targets utilize an ambient light correction feature that improves accuracy. This requires that the target be set to the existing electrical frequency. Normally the U.S. is 60 Hz and Asia/Europe is 50 Hz

Note – the target must be turned on and paired with the PC to change the frequency. Normally, this is set at the factory to match the country it is being shipped to.

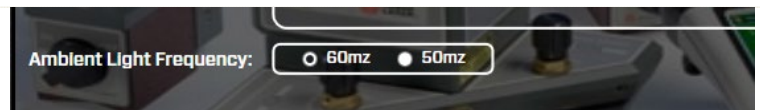

10. **Defined Targets** - You can set up multiple targets if desired. The target names and modes will appear in the **Defined Targets** area.

To select a different target, go to **Step 2** and choose from the **Target** dropdown list, where up to 10 target setups may be stored.

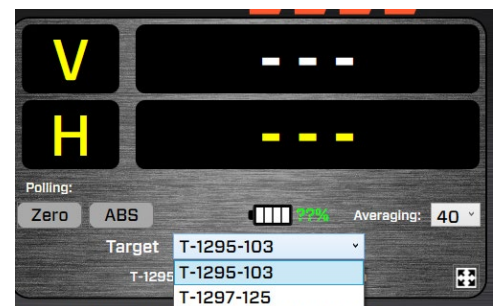
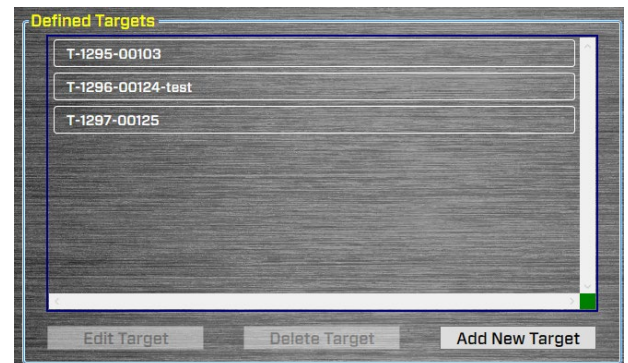

Plane6 Screens - Step 1: Dimensions and Tolerances

Enter the horizontal and vertical dimensions of the plate, as well as the border width, which is the distance from the edge of the plate to the measuring line. Then select the number of points you want to measure for the horizontal, vertical and diagonal lines. Next, select the plate grade, enter the plate serial number and top and bottom temperature (if measured).

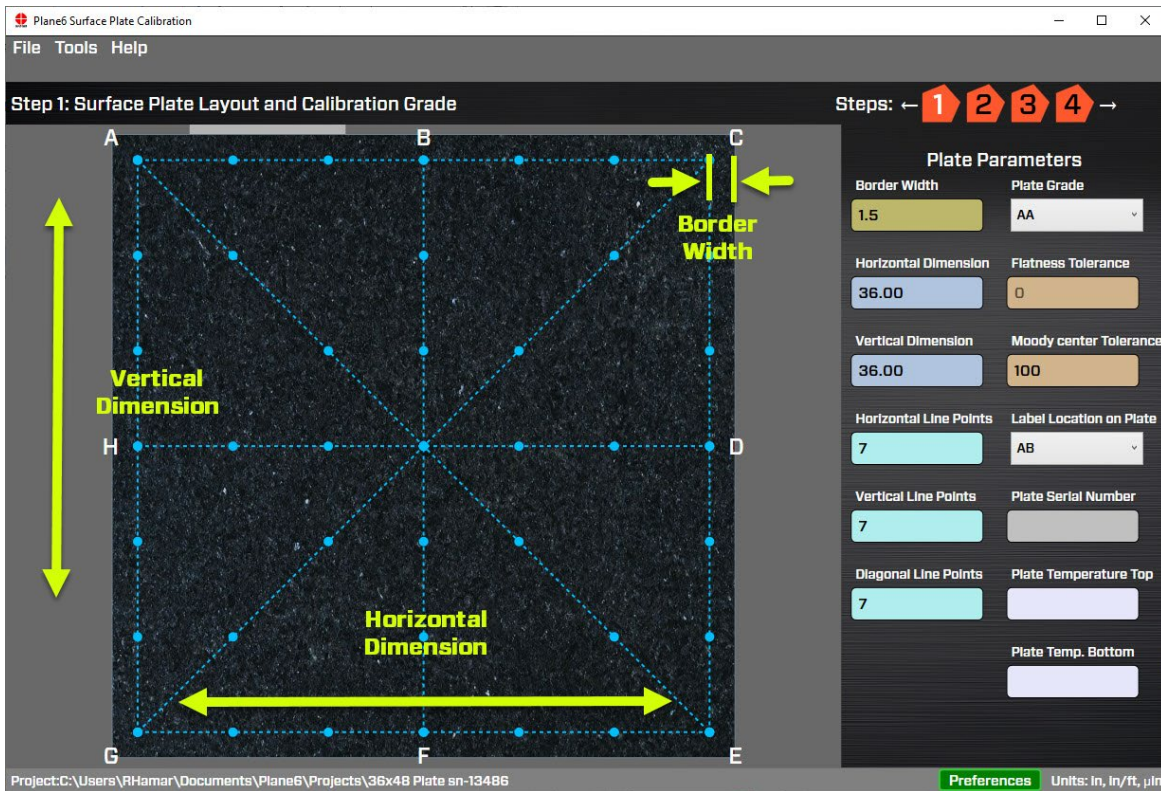

Border Width: Width of the margin between the physical outside edges of the plate and the measurement area. The ANSE B89.3.7.2013 Standard specification typically calls for 1.5 in. (33.1 mm) border spacing. However, some specifications allow for larger borders, so we allow several to be chosen.

Note - the border width chosen here must match up with the border width noted on the Corner Locating Tool - on page 15.

Horizontal Dimension: Outside horizontal dimension of the physical plate in inches or mm's.

Vertical Dimension: Outside vertical dimension of the physical plate in inches or mm's.

Horizontal/Vertical/Diagonal Line Points: The number of points to be recorded for each of the line types.

Plate Grade: AA, A, B or Custom. The *Flatness Tolerance* is set automatically based on B89.3.7.2013 standard. If *Custom* is selected, the *Flatness Tolerance* can be manually set.

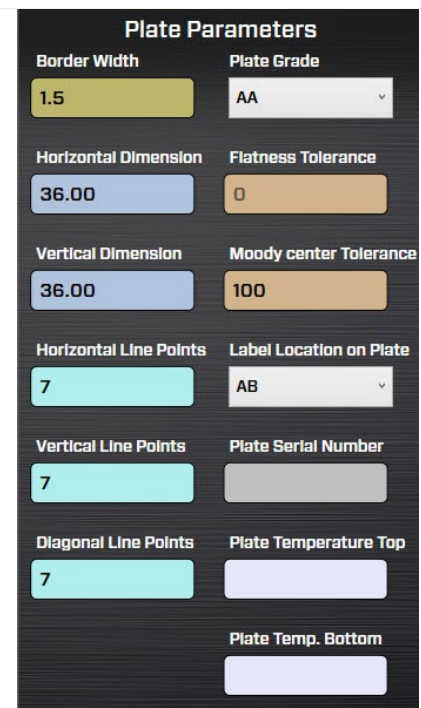

Flatness Tolerance: This displays the plate tolerance based upon the plate grade and diagonal length. It automatically updates when you change the size or grade. If *Custom* is selected under *Plate Grade*, then the display area becomes an entry box where you can enter your own tolerance. The tolerance value is the overall flatness allowance for the plate based upon the ASME-B89.3.7-2013 Surface Plate Specification. The value is the difference between the highest and lowest measured points after the calculations are done. Enter the value and click on any other part of the screen for Plane6 to accept it.

Moody Center Tolerance: As per *Moody Method* procedure, this is the maximum allowed deviation between the intersecting diagonal lines after all point adjustments have been made. If this tolerance is exceeded, it suggests that measurement errors were made, and it is recommended that the data be retaken.

Plate Serial Number: Enter the plate's serial number for the report.

Label Location on Plate: Location of the manufacturer's label applied to the plate. The letters correspond to the letters on the plate graphic A...H points as shown above. *AB* means the plate is located between A & B on the plate.

Plate Temperature Top/Bottom: Temperatures for the top and bottom of the plate (if measured) as the flatness data was recorded.

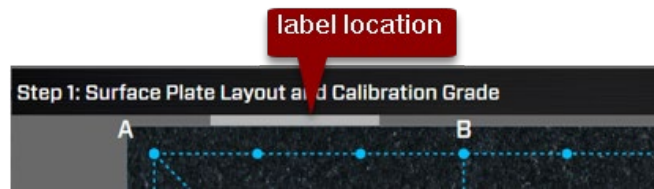

Plane6 Screens - Step 2: Data Collection – Plate and Line Views

Plate View

In *Step 2: Data Collection – Plate View*, the flatness data is recorded for each line segment on the plate. The screen uses a predetermined sequence for recording each line segment that minimizes the time to record the plate data. When setting up the laser, the A-703LM Laser Fixture and L-703S Laser should be placed at the point where the target icon is located and should be pointed in the direction of the arrow (see more information below under *L-703SP How it Works on page 48*).

Plane6 highlights the line segment that it is ready to record in blue. In addition, it will show the point number and ruler dimension for that point. After a data point is recorded, the point-location icon will turn green, indicating it has recorded data, the target icon will move to the next point and the *Selected Data Point* display will show the ruler dimension for the next point to record.

After recording the last point for a given line segment, Plane6 will move the target icon to the next recommended line segment and highlight it in blue.

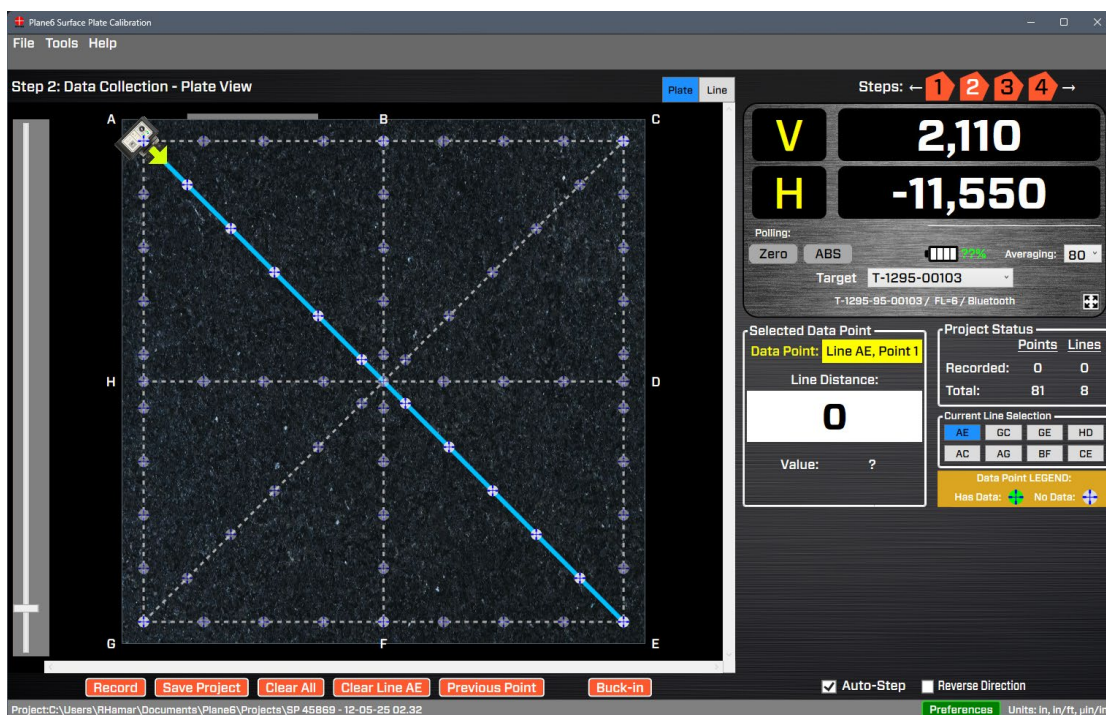

What the Buttons Do

Record – click **Record** or press the *spacebar* to record the data point. After pressing **Record**, a window will open and display the percentage progress of the samples being recorded. When Plane6 is finished sampling, a ding is played and the window will close. The number of samples is changed by changing the *Averaging* in the display area – see below.

Note: When first hitting record, Plane 6 pauses for 2 seconds to let the readings settle. Also, if the laser is blocked during sampling, Plane6 will automatically restart the data-taking.

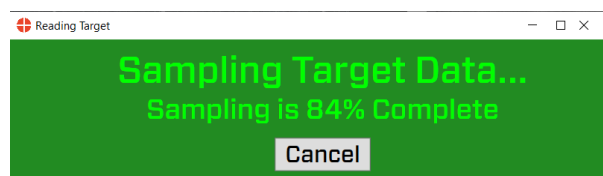
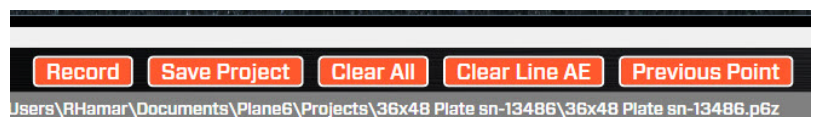

Save Project – click here to save the data already recorded.

Clear All – this clears all the data from all the line segments recorded for the plate.

Clear Line XX – this clears all the data from the line segment currently selected.

Previous Point – this moves the target icon (cursor) to the previously recorded point to re-record it. If you click **Record**, then a window will pop up warning you that a data point was already recorded and asking if you want to overwrite it.

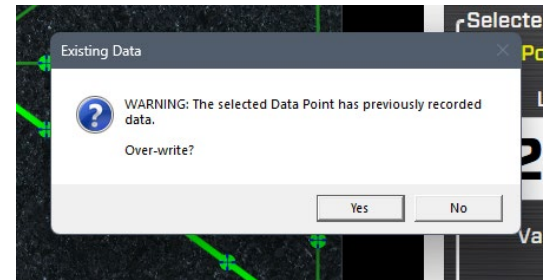
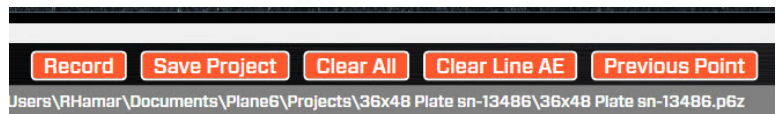

Zero – Click here to zero the display.

ABS – Click here to return the data display to the default absolute (raw) value display from the target. This is a measure of how far from the PSD sensor's center the laser beam is located.

Note – The data values that are recorded are the absolute (raw) values. Zero Mode is only used for the display.

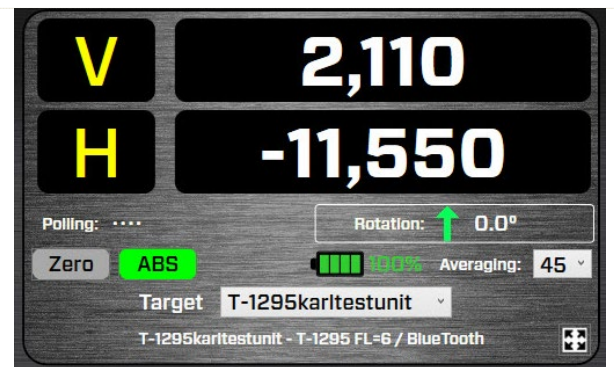

Averaging – enter values from 1 to 200 and this will change the number of samples Plane6 uses to average for each of the values shown in the data displays.

This also changes the amount of sampling the software takes when recording each data point. A value of 45 means that Plane6 will record 45 target values, process them, and record the averaged value as the data value for that point.

Note: *The higher the averaging value, the more noise fluctuations will be dampened out, but also the slower the response time for movements in the laser position. The data updates at ~13 readings per second, so with an averaging value of 26 (after the 2-second pause), the data takes about 2 seconds to finish updating .*

The recommended starting value for most small-to-medium plates in good environmental conditions is 40 (~4 seconds per point) for A & B grades. If doing AA grade, then up the sampling to 60-80 (5-7 seconds per point plus the 2-second pause time).



Target Battery Icon – displays the estimated remaining battery life of the target. It updates continuously.



Target – this is the dropdown list of all the targets that have been set up in *Preferences* to allow you to change the target if using your laptop with different sets of lasers and targets. This is normally not changed unless you are switching laptops and laser/target kits. See **Target - Setup Procedure** on **page 31** to add to this list.

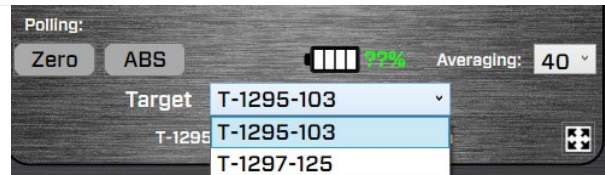

Line View

Step 2: Data Collection – Line View is used to collect the flatness data for one line segment, usually after resurfacing the plate to check to see how well the resurfacing did.

Plane6 Screens: Step 2 – Data Collection – Lapping Line View™

Click on the *Line* tab button to go to **Step 2: Data Collection – Lapping Line View**. Flatness data is recorded for a single line segment, with up to 5 line sets of data stored for each line segment at one time.

You can select any line segment from the *Plate View* and Plane6 will bring in the values from that segment. This allows you to focus on the line segment that has the biggest flatness error when resurfacing the plate.

Grid R – These are the raw values from the *Plate View* tab, which are currently recorded for the selected line either from the plate data or for newly recorded line values.

Grid C – These are the corrected values (end point adjusted to zero), which are automatically calculated once all **Grid R** values are recorded for a given line segment.

L is short for “Line Revision”, so **L1** is for “Line Revision 1,” etc.

L1 R is short for “Line Revision 1, Raw Values”

L1 C is short for “Line Revision 1, Corrected Values.”

Once corrected values have been generated for a line segment, the flatness of each line revision will be plotted in the **Line Chart** at the bottom of the screen. The color of each line in the **Line Chart** corresponds to the color of each line revision, as shown on the far-left side of the data grid.

Note - the original data imported from the *Plate View Data Grid* is also plotted in the graph and uses a white line.

Each individual point in the **Line View Data Grid** can be selected with a left-mouse click and is highlighted by a filled gray background. The information shown in the **Selected Data Point** display corresponds to the selected data point within the Line View Data Grid.



AE	Point 1	Point 2	Point 3	
Grid R	30.00	30.75	30.00	
Grid C	0.00	0.75	-0.25	
L1	R	36.50	36.75	37.50
	C	0.00	0.00	0.75
L2	R	32.00	31.75	32.25
	C	0.00	-0.25	0.00



You can change the line segment by using the **Current Line Selection** control, which features a dedicated button for each individual line segment. By clicking on a new line segment, Plane6 will bring into the Data Grid the values it recorded in **Plate View** for that segment.

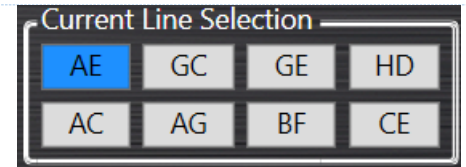

The **Line Chart Visibility** control can be used to toggle the visibility of the plotted line points for all Grid C, L1 C, L2 C, L3 C, L4 C, and L5 C values within the Line Chart control.

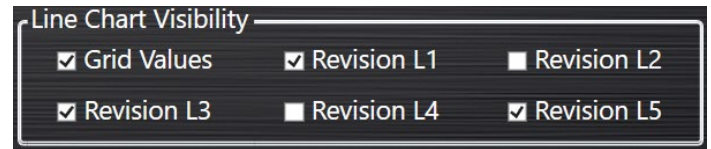

What the Buttons Do

Record – click **Record** or press the spacebar to record the data from the target. After displaying the value in the grid, the cursor will jump to the next oi



New – click **New** to find the next available grid line to record a new set of data for the line. **New** works in ascending order, meaning it searches for the first available data point in L1, then proceeds to check for any available data points in L2, L3, L4, and L5.

Clear Line – click **Clear Line** to erase all previously recorded data point values for a single line revision. **Clear Line** works in descending order, meaning it first clears all recorded data point values for L5, then proceeds to clear all recorded data point values for L4, L3, L2, and L1.

Step 2: Data Collection - Line View

GE	Point 1	Point 2	Point 3	Point 4	Point 5	Point 6	Point 7	
Grid R	1,170	1,180	1,200	1,200	1,170	1,180	1,210	
Grid C	0	0	20	10	-30	-20	0	
L1	R	690	700	720	670	690	700	
	C	0	10	30	-30	-10	0	
L2	R	1,620	1,580	1,650	1,610	1,620	1,590	
	C	0	-30	40	10	20	-10	0
L3	R	1,570	1,550	1,530	1,530	1,560	1,560	1,530
	C	0	-20	-30	-20	10	20	0
L4	R	1,430	1,410	1,420	1,400	1,410	1,440	1,420
	C	0	-20	0	-30	-10	10	0
L5	R	1,450	1,420	1,450	1,380	1,430	1,420	1,440
	C	0	-30	0	-60	-20	-30	0

Clear All – click **Clear All** to erase all previously recorded data point values for all line revisions, including L1, L2, L3, L4, and L5.

Dump To Grid – click **Dump To Grid** to replace all previously recorded Grid R values with the data point values assigned to the currently-selected line revision. This will “dump” the data into the **Plate View** data grid updating the old data with the newly recorded data. You can then go back to Step 3 to see how this affects the overall flatness data.

Plane6 Screens - Step 3: Results

When all the data is collected, click on the Step 3 icon to bring you to **Step 3: Results**. This shows the Moody Method calculations to get the overall flatness results.

The results are summarized in the *Results* Table. The plate-grade tolerance, chosen from Step 1, is applied to the data and a red X or green checkmark is displayed to indicate if the overall flatness is in or out of tolerance.

A graph is also shown, giving a snapshot of the flatness data. A more dynamic graphic of the flatness is shown in **Step 4: Graph**.

The data tables for each line segment are also shown, along with the various values needed to calculate the overall flatness. The **Zero Low Point** column is the corrected flatness value for that line segment. The zero point is the lowest value of all the sets of data.

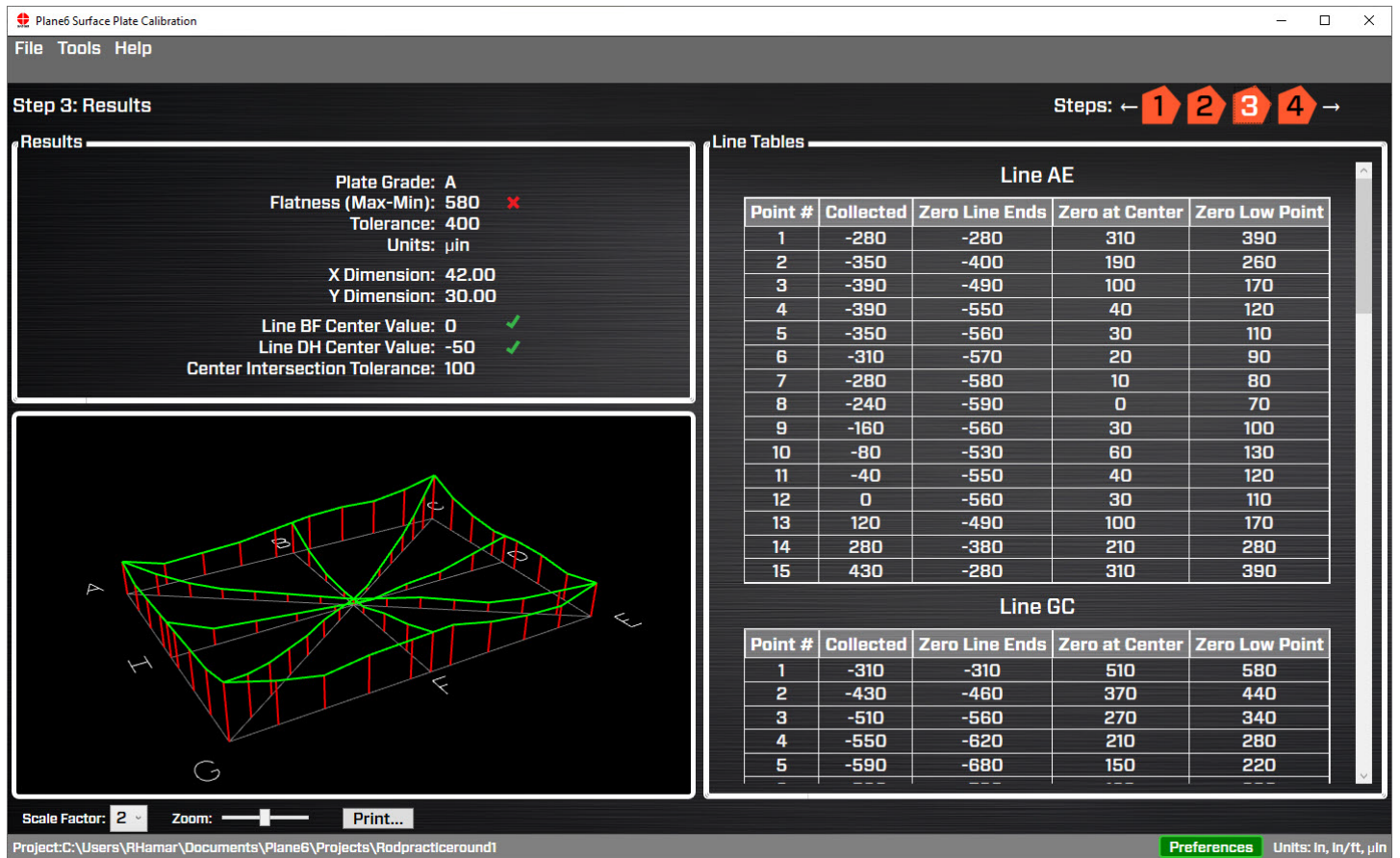

Figure 27 - Plane6 Step 3: Results

Center-Line Tolerance Data Quality Check

Check to make sure both center-line value tolerance checks are in tolerance. This is a data quality check and an in-tolerance value means it's a good set of data. A green check mark indicates it's in-tolerance.

However, if the center value is out of tolerance (**X**), then the B89.3.7-2013 Surface-Plate Standard recommends that the data be retaken. You can either retake the entire plate data or you can first try to retake the data for the line segment that is out of tolerance. In the example below, you would retake the BF line data. As long as this data is taken within a reasonable amount of time from the time the overall plate data was recorded, then this is a valid way to try to correct the out-of-tolerance condition.

Procedure to retake a line segment when the Center Tolerance Check Fails.

1. Open the saved file if it's not already opened.
2. Go to Step 2 and select the line segment that is out of tolerance.
3. Set up the laser, laser fixture, straightedge and target, as detailed above, for the line segment you want to re-shoot.
4. Click on *Clear Line XX* button at the bottom of the screen (in this case, the button will say *Clear Line BF*).
5. Retake the data for the line.
6. Go to Step 3 to see if the results are now in tolerance.
7. Save file.

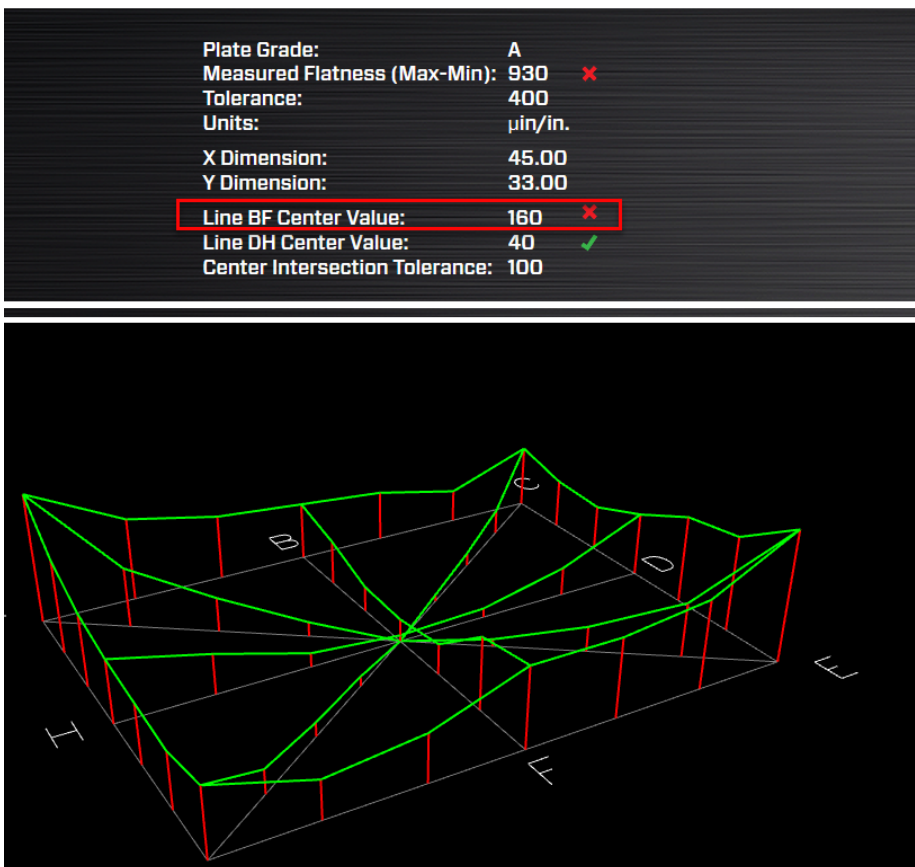

Plane6 Screens - Step 4: Graph

To see a more comprehensive graph of the flatness results, click on Step 4: Graph. This takes you to a user-adjustable graph where you can rotate the graph, zoom in and out and adjust the graph to study the results.

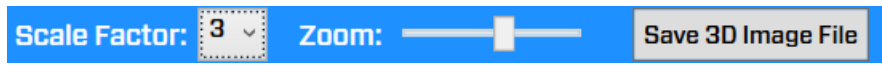

To rotate the graph, use a mouse to click and drag left/right or up/down. To make the elevation of the graph lines larger, click on **Scale Factor**. To zoom in/out on the whole image, slide the bar under **Zoom** or use the scroll.

You can also save the graph as a JPG file by hitting the **Save 3D Image File** button at the bottom of the screen. This saves the screen to a JPG file on your hard drive.

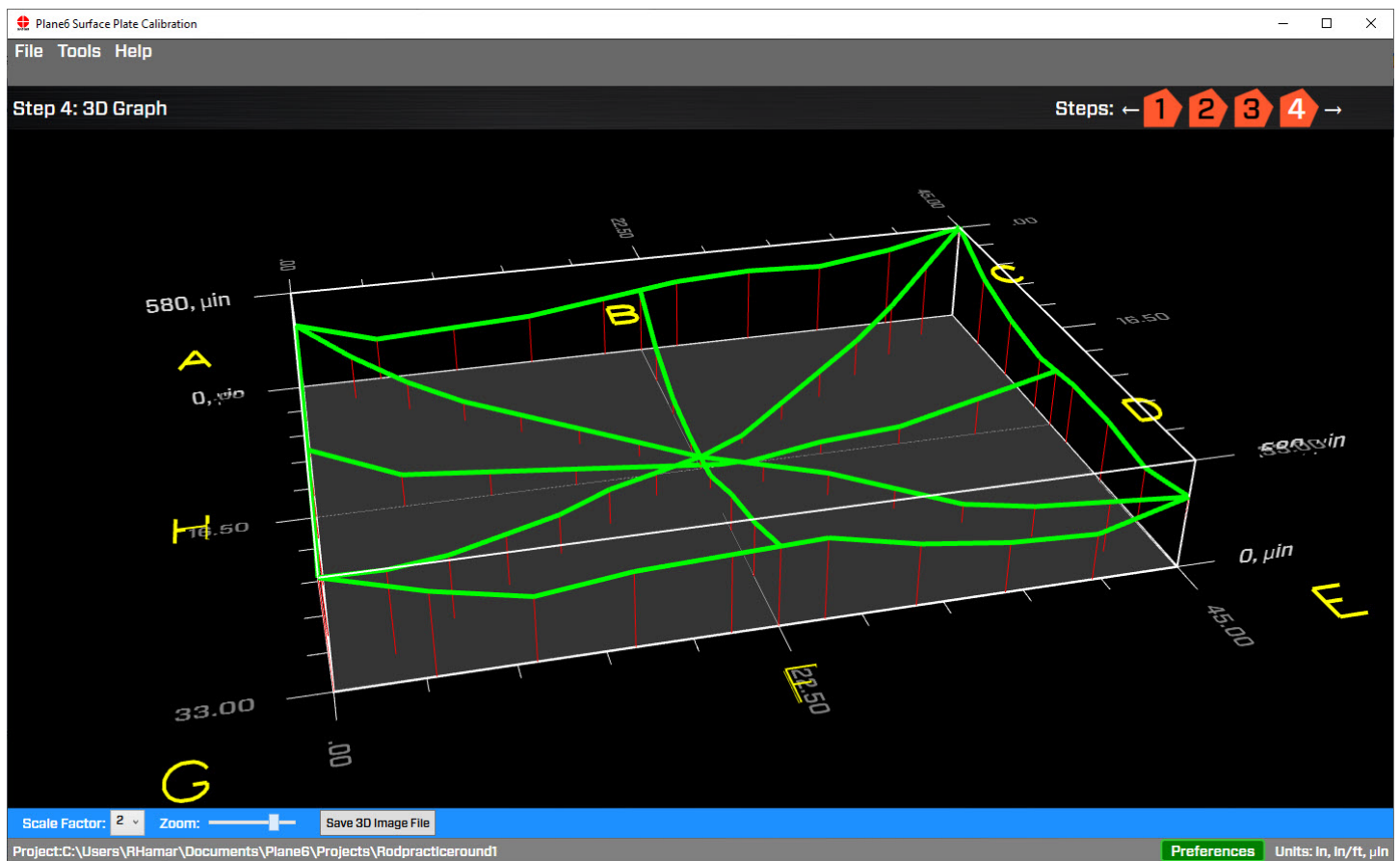
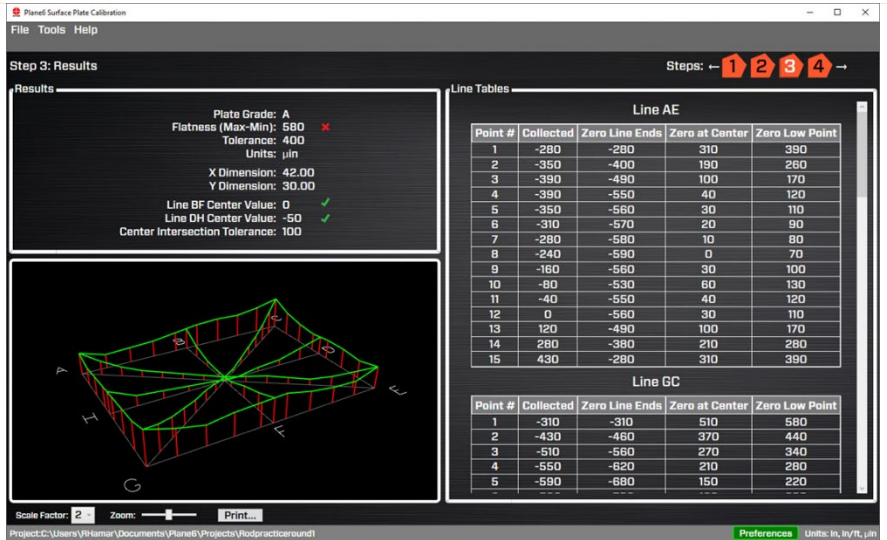

Figure 28 - Plane6 Step 4: Graph

Interpreting the Plus and Minus Signs in the Live Displays

The signs of the data displays indicate the position (high/low or left/right) of the target is relative to the laser beam. See the interpretation below.



Vertical Axis

A **+V** center value indicates the target is higher than the laser beam.

A **-V** center value indicates the target is lower than the laser beam.

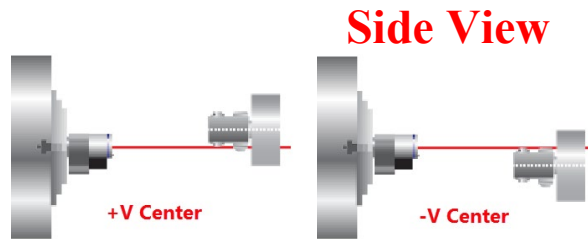

Horizontal Axis

A **+H** center value indicates the target is to the right of the laser beam when looking from the laser into the T-261 target.

A **-H** center value indicates the target is to the left of the laser beam when looking from the laser into the T-261 target.

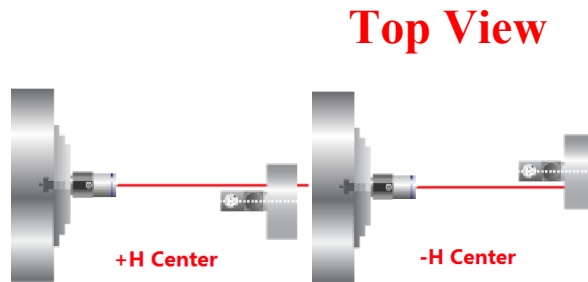

Notes on Using the L-703SP

1. Notes on Moving the Target when Taking Data

- When moving the target to the next point, it is important to only hold the straightedge to prevent it from moving. There are rubber pads on the bottom to help it from sliding, so light pressure on the straightedge will keep it from moving.
- However, during the measurement of each line, **DO NOT TOUCH THE L-703SP-LM Laser Fixture** since it does not have rubber feet and can be moved easily. Moving the fixture or pressing on top of the fixture can cause the laser beam to move, which may take up to 30-60 seconds to settle down. Either of these issues can lead to additional measurement uncertainty.
- If the A-703SP-LM moves, we **strongly recommend** repositioning it, making sure it is properly touching the straightedge, clearing the data for the line segment, and re-recording the data for the line segment.

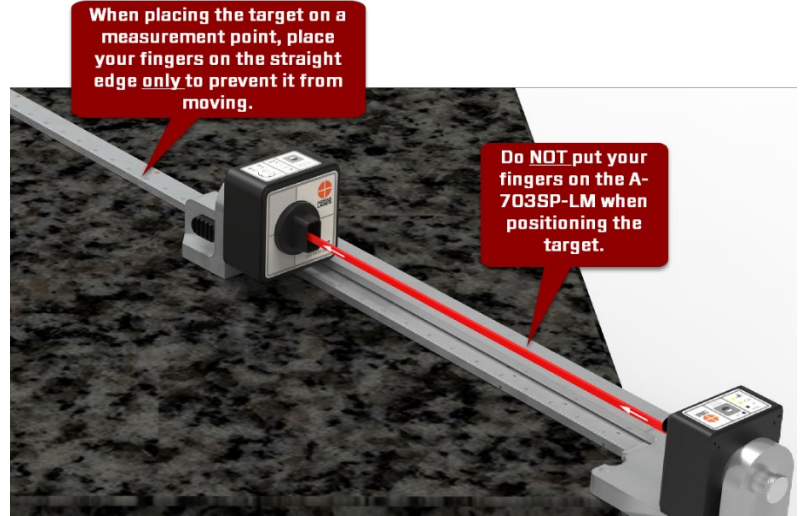

2. Notes on Moving the Straightedge for a New Line Segment

When moving the A-703SP-LM Laser Mount and A-703SP-SE Straightedge:

- Do not pick up the A-703SP-LM from the middle of the fixture.
- Place the straightedge on the line using the corner locating tool to position it correctly, as shown above in Step 2. Remove the tools.
- Place the laser mount next to the straightedge (see above) and slide it so it hits the straightedge at both ends. You can “pinch” them together to make contact but try to keep the straightedge from moving.
- Make sure to line up the start of the scale with the green mark on the laser fixture.
- Wait for 30-120 seconds, depending on the plate grade (**Figure 11 - Laser Fixture Wait Times**), before taking data.
- Once the laser fixture is in place, do **NOT** touch it when taking data. This is because even small movements of the laser fixture could cause the laser to move, especially at the far end of the line, which would require restarting the data taking for the line segment.
- If you change the straightedge to a different length, we recommend you redo the laser Buckin as noted in Step 5a & 5b. A different straightedge will have a

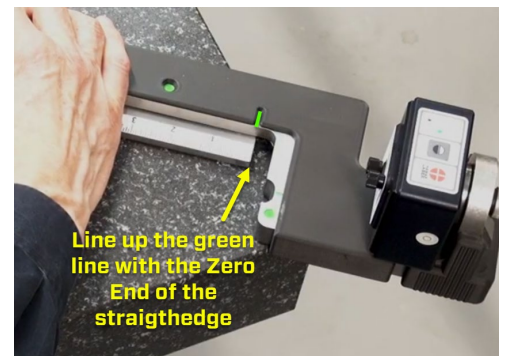
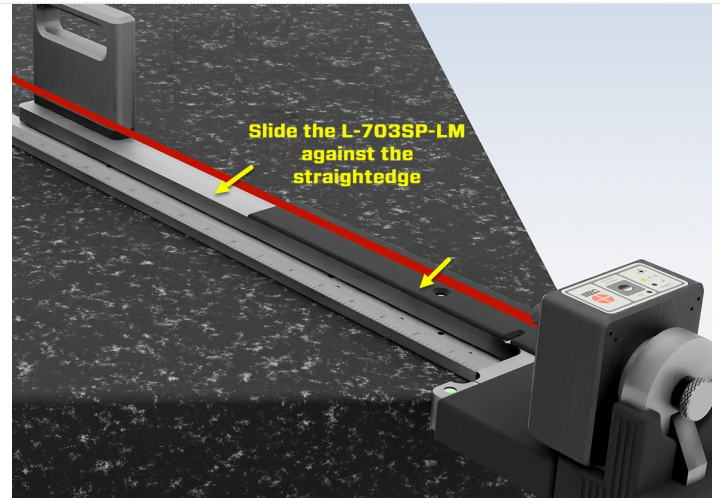

different straightness profile, so the laser may need to be adjusted to be parallel to the new straightedge.

3. Notes on Taking Data:

- a) **Display Value Tolerance** - Pay attention to the H axis value. If the value gets higher than 10,000 $\mu\text{in.}$ (760 μm), then the Plane6 data display will turn orange, indicating that this is too far off center in the horizontal axis. This may mean the laser fixture moved. Check to make sure the laser fixture is still against the straightedge. If not, then move them together again.

Then move the target to the end of the straightedge and see if the orange color disappears. If so, this means it's back in spec. Then hit **Clear Line XX** to restart the data taking for the line segment.

If it's still orange, you can simply adjust the H axis until it's less than 10,000. Then hit **Clear Line XX** and retake the data for that line.

- b) **Keep Display in Zero Mode** – When recording data, keep the displays set to Zero Mode to maximize the display tolerance range. For example, if the ABS H value is 9,000 $\mu\text{in.}$, this leaves only 1,000 $\mu\text{in.}$ of range before the display turns orange. However, if you have it set to Zero Mode, you will have a lot more range of laser movement before the displays turn orange.

Note – When a data point is recorded, the raw value (unzeroed) is stored, so if you hover over a point, the recorded value could be substantially different than the display value.

- c) **Checking Recorded Data Points** - You can always check data values for a given point by hovering over it and seeing the values or by clicking on it and seeing the values in the table.

- d) **Retaking a Data Point** - You can also click on a data point (green circle) on the plate image to see the value. To re-record it, move the target to the correct location and hit Record. Plane6 will ask if you want to re-record the value.

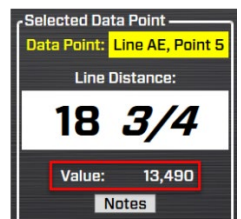
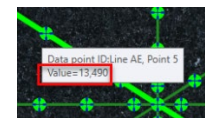
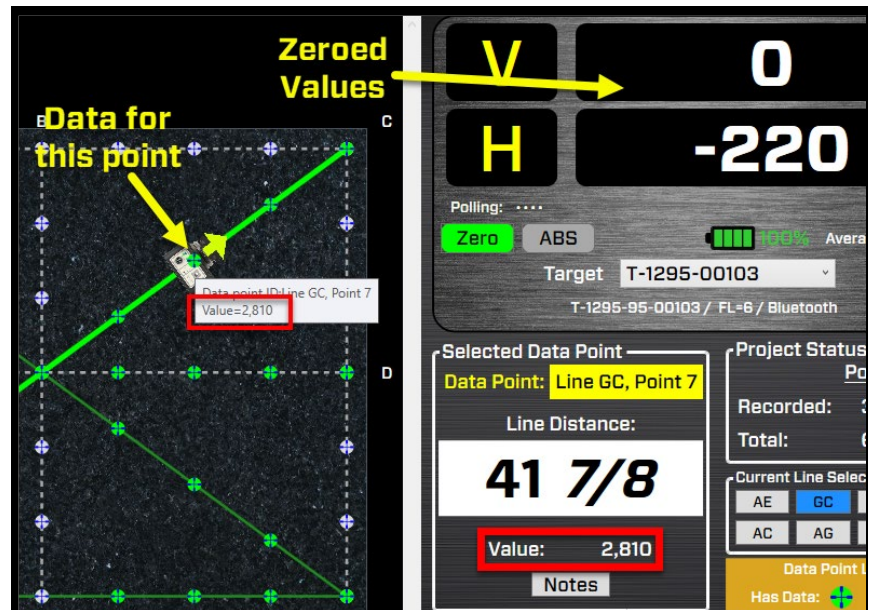
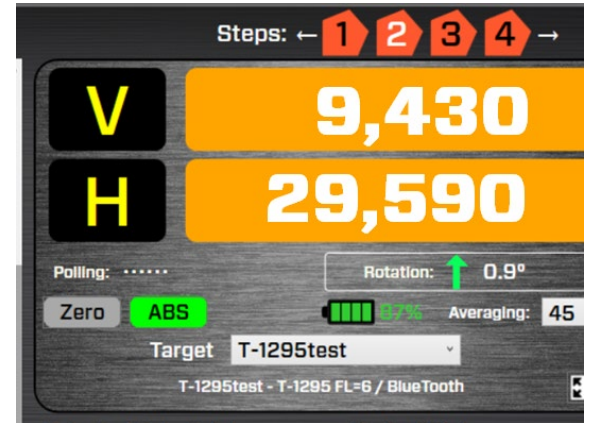

Note - After re-recording the point, Plane6 will automatically jump to the next point, whether it has been recorded or not..

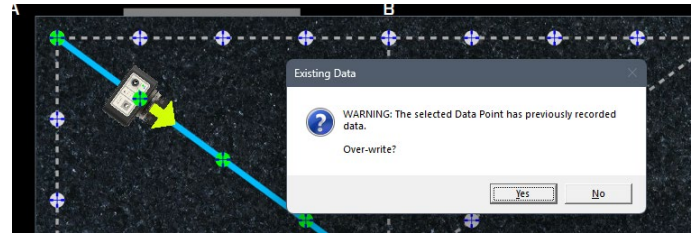
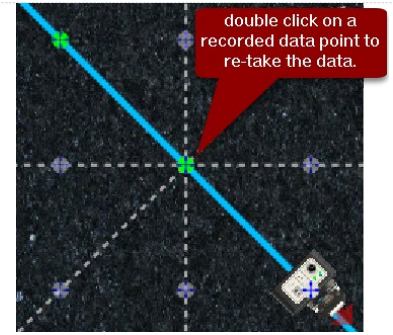

e) **Manually Picking Data Points** - You can turn off Auto Step if you want to move the target icon manually. First, click on the line segment you want and then click on the point you want to record. The target icon should be over the point indicating it's ready to take data.

f) **Reversing Direction on a Line Segment** - You can also hit Reverse Direction to change the direction of a line if you need to. See on page 59, L-703SP - How to Do a Reverse Line Check Using the A-703SP-LM-M for more details.

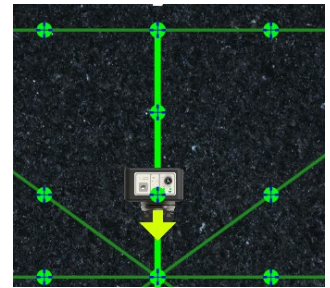

g) **Data Time-Outs**

There are two issues that can cause the data recording to restart:

a. The data buffer does not get enough samples for the averaging in the time allotted, so it will "timeout" (T/O). For example, if the Avg is set to 40 and the buffer only has 25 samples and the time has exceeded 4 seconds, you will see the timeout message. The formula for the T/O = (Avg/2)/13, subject to a minimum of 3 seconds. So, for 40 avg, the T/O is $40/2 = 20/13 = 1.5$ but that is less than the minimum, so the T/O is 3 secs.

b. The software receives an "Off TGT" message from the target. This will trigger the software to "flush the buffer" and restart the data-taking routine. This is to avoid potential bad data being recorded as the laser beam is being partially blocked. Plane6 will automatically retake the data unless **Cancel** is clicked.

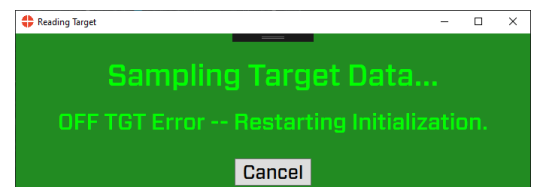
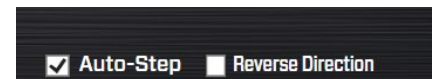

L-703SP - How It Works

Step-by-Step Surface Plate Calibration Procedure

Step 1 – Assemble Laser and Laser Mount

Turn on the L-703S Laser and T-1297 Target.

Insert the L-703S into the L-703SP-LM Laser Mounting Fixture and tighten the thumb screw very tight and make sure to keep the top of the laser level. Turn on the laser and make sure it is in *Double-Blink Mode* (See Page 3 of the manual). The LED will blink twice and pause, blink twice and pause, etc., when in *Double-Blink Mode*. Turn on the T-1297 Target.

Note: we recommend a warm-up period for the laser and target and an ambient temperature “soak” time for the laser fixture. on page 17 for details.

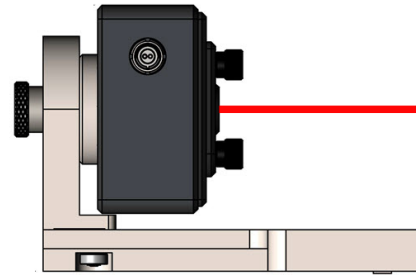

Step 2 – Plate Setup

These parameters need to be entered:

- the plate border size (default is 1.5 in. 37 mm). See Step 2 to determine what border to use.
- the plate grade,
- the plate size in X & Y,
- the number of points to measure for the horizontal, vertical and diagonal line segments,
- pick the label location,
- the plate serial number,
- the temperature for the top and bottom of the plate and,
- the alignment tolerance if you are using custom tolerances.

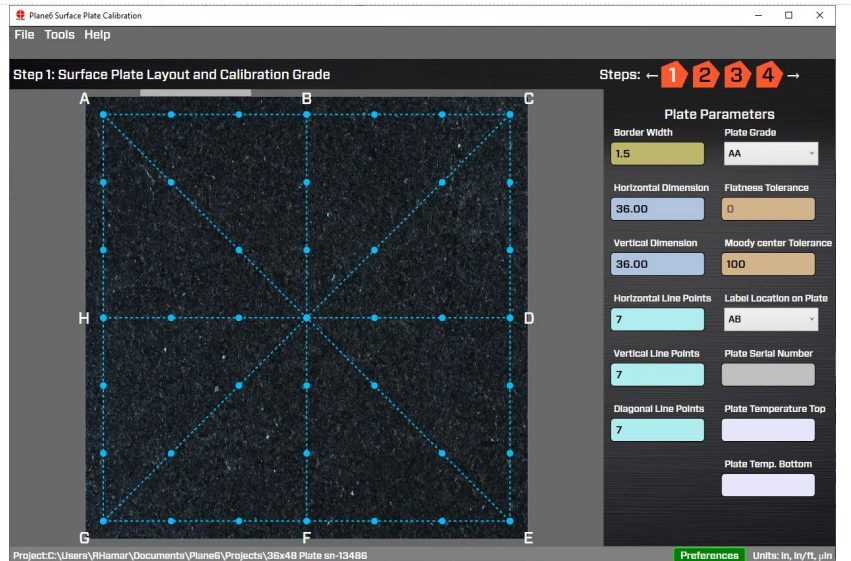

Step 3 – Use Corner-Locating Tool to Mark Mid Points

The A-703SP-SE-CLT-1.5 Corner-Locating Tools are supplied to create the proper border width and help align the straightedge to the line segment on the plate, speeding up the process. Select the border width that matches the tool (see the underside of the tool).

Note – We supply a 1.5 in. and 2.0 in. corner tool (A-703SP-SE-CLT-1.5 & A-703SP-SE-CLT-2.0), but we can make up different sizes if desired (2.5 in. or 3.0 in.). Enter the border-width value for the tool in Border Width in Plane6 Step 1.

- a. Use a tape measure to find the midpoint for each perimeter segment line, using the locating tool to show you where to position the tape measure and where to make the mark.
- b. Do this for all 4 outside line segments.

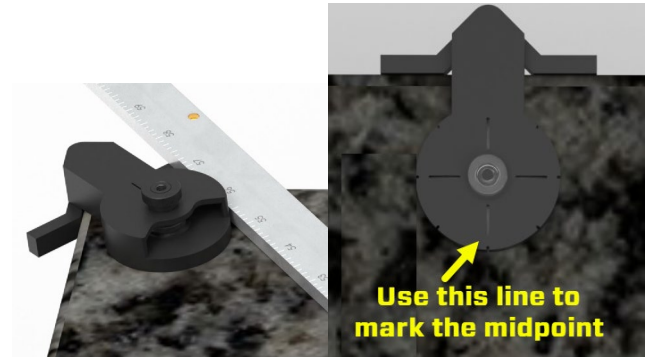

Step 4 – Place Straightedge on the Diagonal Segment

Plane6 preselects the line sequence that you will measure. This can be overridden but this sequence was selected to minimize the time it takes take all the data. To measure the diagonal:

- i. Locate the first diagonal segment as recommended by Plate6, using the plate label location to orient yourself (see screen below).

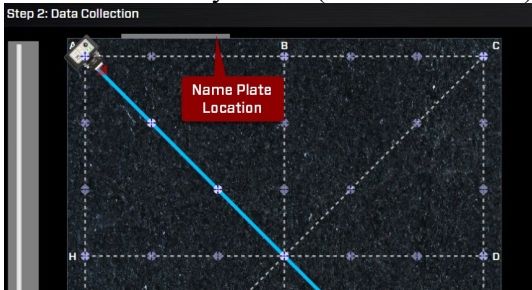

- ii. Place the A-703SP-SE-CLT-1.5 on both corners of the diagonal. Place the side of the straightedge with the ruler (scale), so it is touching the corner locator. See image. In general, you always want the *scale side* of the ruler to be touching the locator tool.
- ii. Position the end of the straightedge to line up with the line on the rotating-edge-alignment tool – see image.
- iv. Now the straightedge is located next to the line segment that you need to measure, so that when the target is put down against the straightedge, it is directly over the line segment.

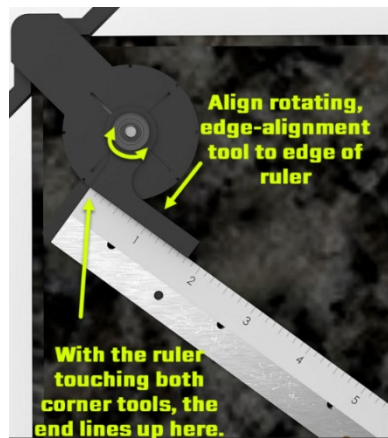

Step 4a –Place L-703SP-LM + L-703S next to the straightedge

- i. Find the correct corner on which to place the A-703SP-LM from the Step 2 Measure Screen, keeping track of the name plate location. Normally, this is on line AE.

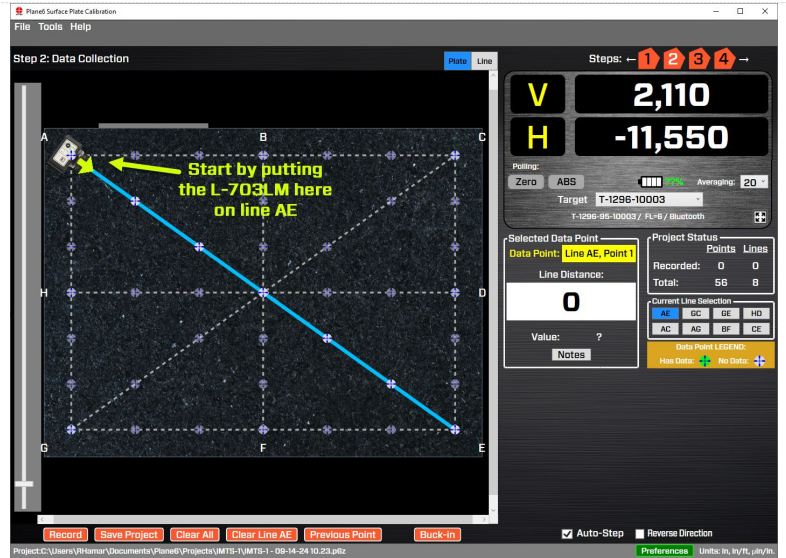
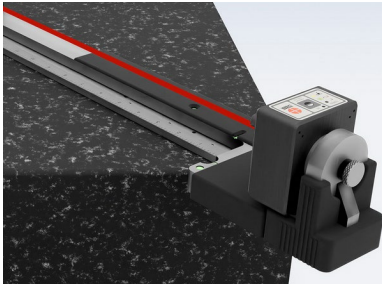

- ii. Place the A-703SP-LM on next to the straightedge. Then, holding down the straightedge, slide the laser fixture against it to make it parallel to the straightedge and line segment. Squeeze them together so the bearings on the bottom of the laser fixture make contact with the straightedge. Then slide the laser fixture along the straightedge until the green line is aligned to the end of it.

Note: After positioning the A-703SP-LM, wait at least 60 seconds before taking data. See Figure 11 for more details.

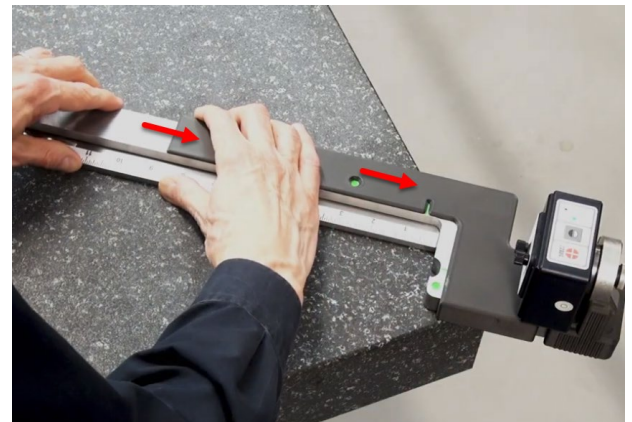
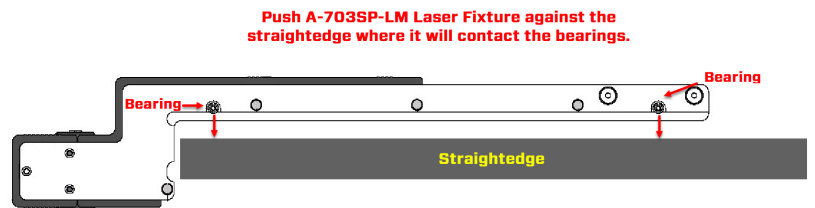

Step 5 – Assemble the T-1297 Target and A-1297-SP Measuring Base

Now assemble the T-1297 Target into the A-1297-SP Precision Measuring base. Notice that the T-1297 has an alignment ball. This should be inserted into the slot on the A-1297-SP to align the target to the A-1297-SP base's measuring feet. Tighten the thumb screw very tightly.

Turn on the T-1297 and use *Center Mode* (See Page 5).



Step 5a – Place T-1297 Target & Base on the Plate

Place the T-1297 Target and Base on the plate near the laser and *gently* push it against the straightedge, lining up the *Measuring Plane* of the target base with the zero point on the scale (see image). Check to make sure that the **H Axis** value is less than 10,000 μm . (250 μm), which it normally is.

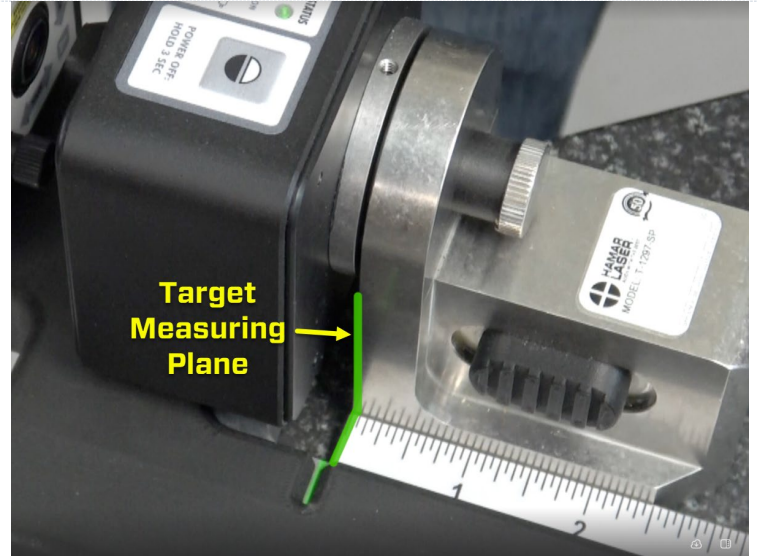

Zero the display by clicking **Zero**.

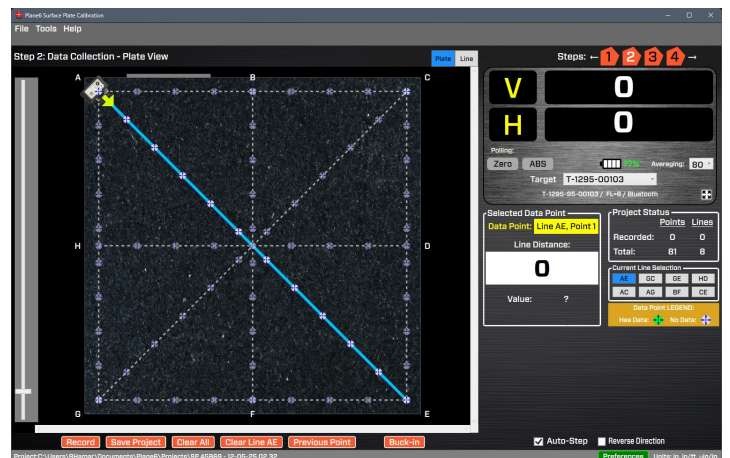

Step 5b – Move the T-1297 Target & Base to the Far End of Straightedge and Align Laser

a. Move the T-1297 Target + Base to the *far* end of the straightedge and gently push it against the straightedge. This is the Far Reading.

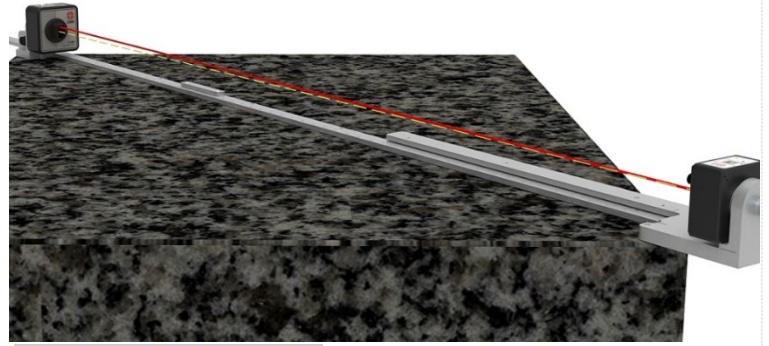

b. Adjust the H (yaw) and V (pitch) axis adjustments on the L-703S laser to tilt the laser beam until the display values equal the Set Points, using these formulas:

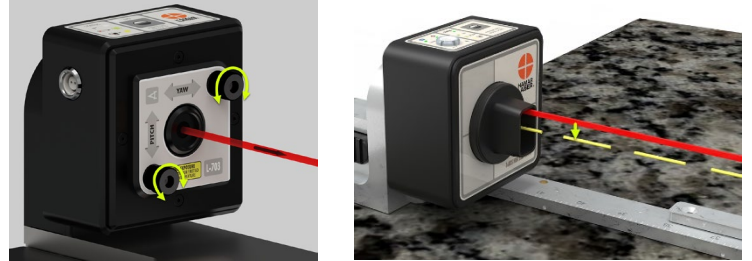

- Line Length < 18 in.:
 $Set\ Point = (-.20) * V\ Far\ Reading$
- Line Length > 18 and < 36 in.:
 $Set\ Point = (-.15) * V\ Far\ Reading$
- Line Length > 36 and < 54 in.:
 $Set\ Point = (-.10) * H\ Far\ Reading$
- Line Length > 54 in.:
 $Set\ Point = 0$

Adjust the laser until you are within $\pm 300\ \mu\text{in.}$ of the Set Point value.

c. Move the target back to the Zero Point to confirm the target readings match the Set Points to within:

$\pm 1,500\ (\pm 35\ \mu\text{m})$



This aligns the laser beam to the straightedge and puts it on the most accurate part of the PSD sensor.

Note - We need to get the laser closely aligned to the straightedge, but not perfectly aligned, so if you are over the 1,000 $\mu\text{in.}$ by 50 $\mu\text{in.}$, then that's ok.

Example:

- Zero target at Zero Point,
- Moved it to the far end of the straightedge at 54 in., where the values are:

V reading far point is +14,880 $\mu\text{in.}$
H reading far point is -21,180 $\mu\text{in.}$

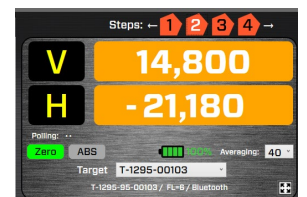
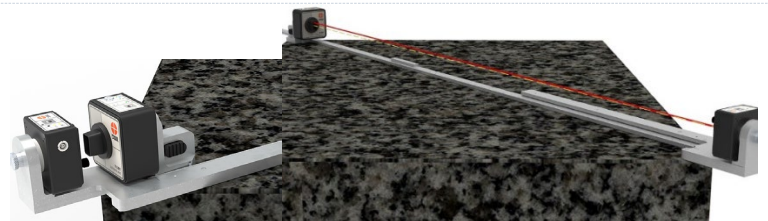

- Calculated the Set Points – multiply values by 0.1 and change the sign

$$V \text{ Set Point} = (-.1) * V \text{ far reading.}$$

$$H \text{ Set Point} = (-.1) * H \text{ far reading.}$$

V Set Point = -1,480 μin
H Set Point = +2,180 μin

- Steered the V & H adjustments until the display is within 300 μin . of these Set Points:

V = -1,480 \pm 300 μin .
 H = +2,180 \pm 300 μin

- Move the target back to the Zero Point and make sure the values are close to the Set Points within a tolerance of: \pm 1,500 μin (\pm 35 μm), so now the values are:

V: 710
H: 1660

Subtract the values from the Far Point:

V -1,540 - - 710 = 832
H +2,090-1660 = 430

So these values are good and the laser is bucked-in (aligned to the straightedge) and ready to record data.

Step 5c – With the T-1297 at the Near Position, Start Recording

With the target at the Zero Point, first, click Zero to re-zero the display. Keep the target in Zero Mode when recording data. Now click **Record** to record the first data point. When positioning the target, line up the *Measuring Plane* (front edge of target base mounting surface) with the ruler dimension before hitting **Record**. In this case, it should be on the zero (0) point on the ruler.

Note – for the zero point, most of the straightedges have a stop pin on the ruler to let you know you're at the zero point.



After steering Set Points are:



After moving to Zero Point, the values are:

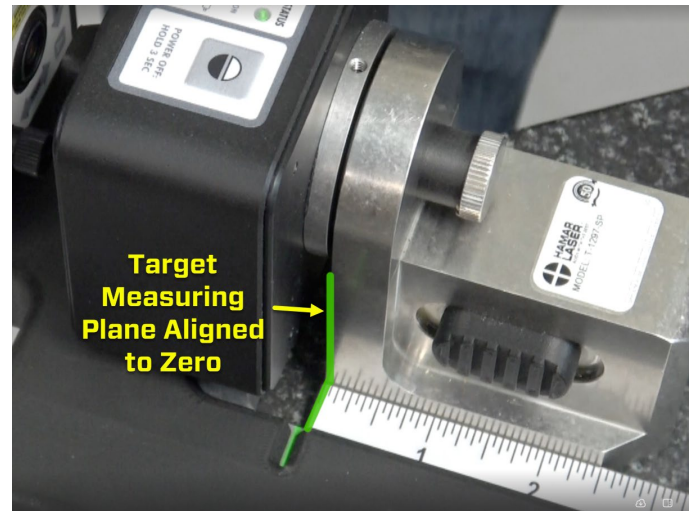
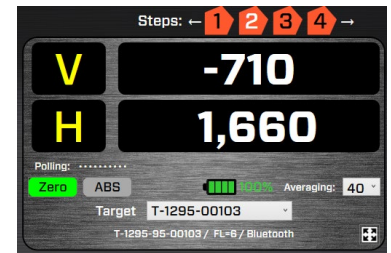

Note – When a data point is recorded, the raw value (unzeroed) is stored in the data table, so if you hover over a point, the recorded value could be substantially different than the display value. See image.

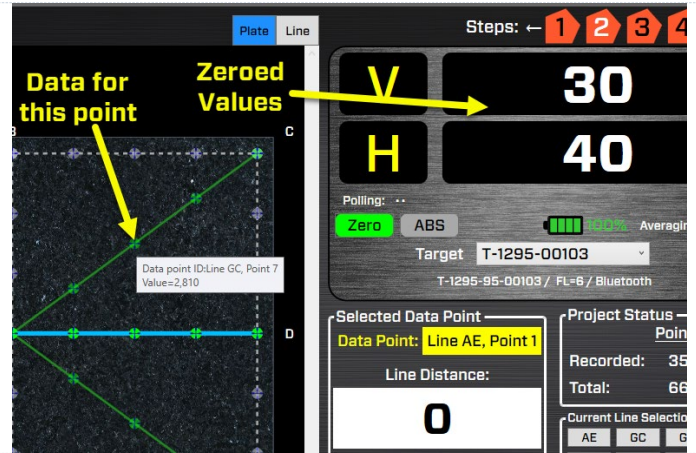

Step 6 – Move to Next Point and Continue Recording

Move to the next point by looking at the *Line Distance* display in **Plane6 Step 2** to tell you where to position the target. Click **Record**. Continue recording until all the points are taken.

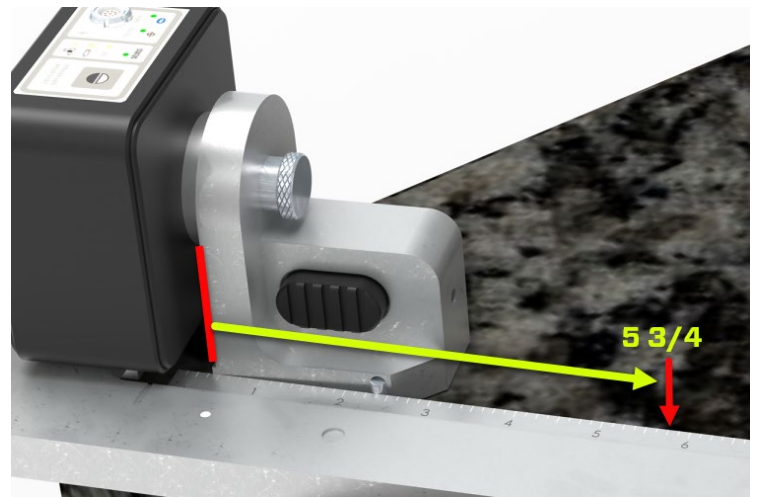
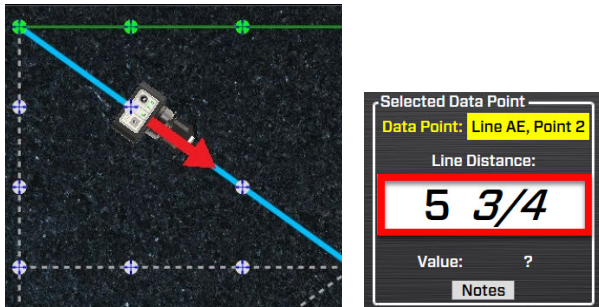

Step 7 – Move Laser to Second Diagonal GC and Record Data

- Plane6 automatically moves the recording line segment to the next line as shown in the *Current Line Selection* table, which is GC.
- First, take off the L-703SP-LM Laser Mount and set it aside.
- Then move the straightedge to the second diagonal using the corner locator tools to position the straightedge.

Note - the location of the target icon on the screen shows where to put the laser fixture.

Again, make sure the straightedge is to the right of the corner locating tools and aligned with the mark as shown above.

- Place the L-703SP-LM Laser Mount on the straightedge as shown in Step 3a above. Place the target at the near position and you are ready to record.

Project Status	
Points	Lines
Recorded: 49	7
Total: 56	8

Current Line Selection			
AE	GC	GE	HD
AC	AG	BF	CE

Data Point LEGEND:
 Has Data: No Data:

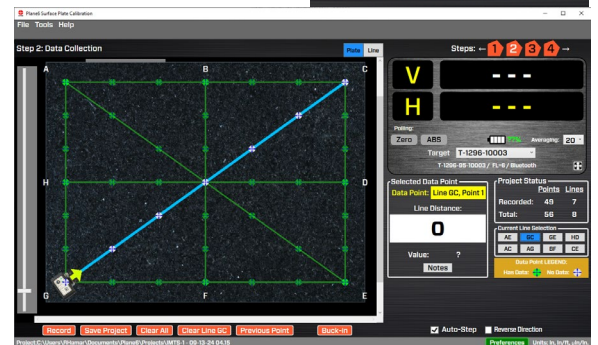

Note - you do *not* need to re-adjust the laser beam since you are using the same straightedge, which means the alignment of the laser to the straightedge should hold its position, so after positioning it and the L-703SP-LM, you can start recording.

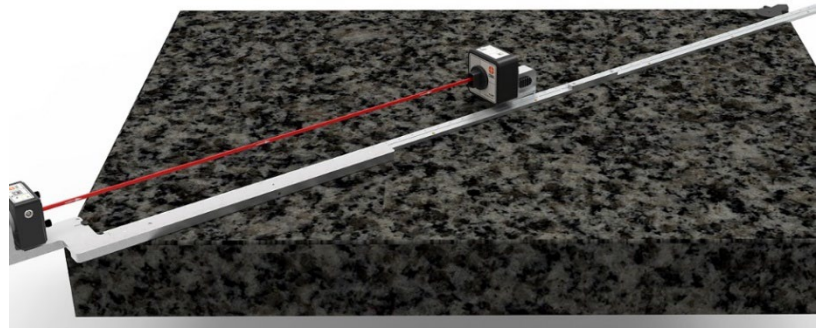

Step 8a – Move Laser and Straightedge to Outside Edge GE and Record Data

Now we move to the next line segment, an outside edge, as shown in the *Current Line Selection* table (see below), usually Line GE. Pay attention to which edge to record, as shown in Step 2. Also, pay attention to which end of the line to put the L-703SP-LM Laser Fixture on. For line GE, the laser fixture will be placed on the lower right part of the plate and will shoot to the left.



Find the straightedge that best matches the length of that side of the plate. See Step 2 for instructions on lining up the straightedge to the corner locating tool.

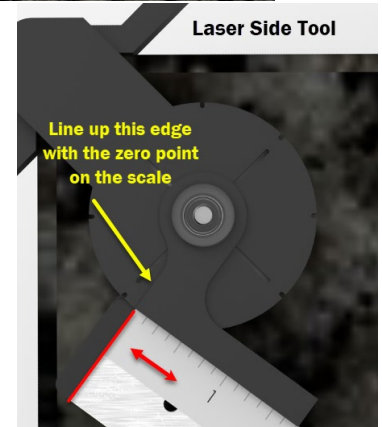

Current Line Selection			
AE	GC	GE	HD
AC	AG	BF	CE

Data Point LEGEND:
 Has Data: No Data:

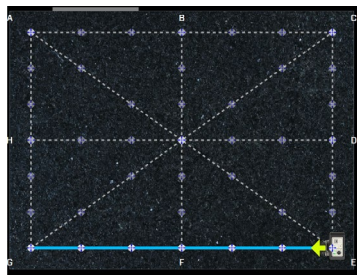

Place the L-703SP-LM Laser Mount on the straightedge as shown Step 3a above. Place the target at the Zero Point.

Note – we recommend that the extra length of the straightedge be no longer than 1/3 of the edge of the plate. This is to ensure that the straightedge does not move around when you are taking data. This can happen because, as the straightedge gets

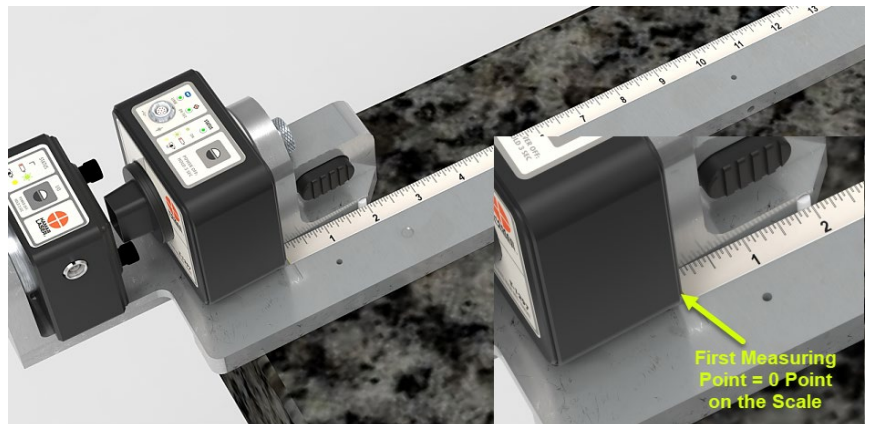

longer relative to the plate edge, it tends to want to fall off the plate.

Step 8b – Zero Target and Move to Far Point (Optional)

If you changed the straightedge, then it is a good idea to check the laser buck-in (alignment) to the new straight edge. So click Zero and move the target to the Far point to check the buck-in. The values should be close to zero within: $\pm 1,500$ ($\pm 35 \mu\text{m}$)

If they are outside this range, then repeat the buck-in procedure in Step 5b (page 49).

Step 8c – Record Data for Line GE

If the values are within the range noted in 8b, then you're ready to record the data. Put the target at the Zero Point and hit Record. Record the rest of the points on GE as shown above.

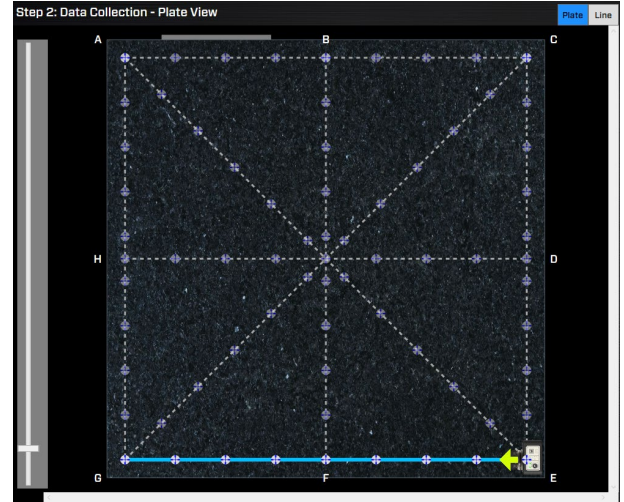

Step 8d – Record Mid-Point Line Segment HD

Using the mark made by the A-703SP-SE-CLT-1.5 Corner Locating Tool (see Step 3), position the Corner Locating Tool on the midpoint of the outside edges and align the mark on the locating tool with the mark on the plate.

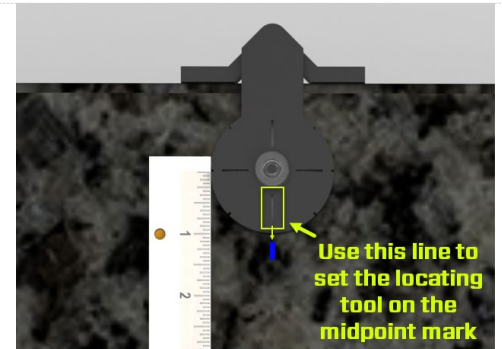

Step 8e - Record Second Outside Edge AC

Locate the second outside edge recommended by Plane6, usually Line AC and repeat the process in Step 7a, 7b and 7c.

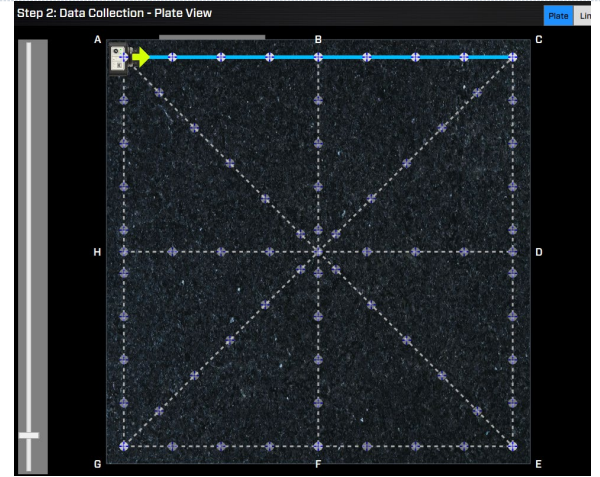

Step 8f - Record Data for the Next Outside Edge AG

If you had to change the straightedge, then repeat the laser buck-in check from 8b. If the values are within the range noted in 8b, then you're ready to record the data. Put the target at the Zero Point and hit Record. Record the rest of the points as shown above.

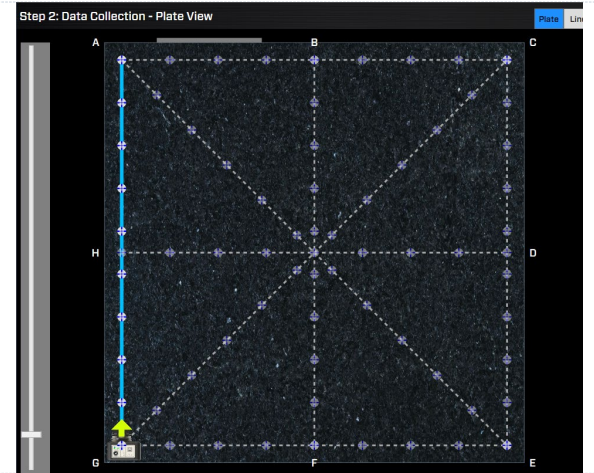

Step 9 - Record the Rest of the Line Segments

Record the rest of the line segments, following the recommended sequence from Plane6.

Project Status	
Points	Lines
Recorded: 0	0
Total: 81	8

Current Line Selection			
AE	GC	GE	HD
AC	AG	BF	CE

Data Point LEGEND:

Has Data: + No Data: +

Step 10 - Review Results in Step 3 Results

Now, click on Step 3 to view the results. The plate grade is shown, the tolerance for that grade and the overall flatness results from the data. A green check mark or red X tells whether it's in or out of tolerance.

There is also an additional check for the center-point elevation difference as directed in the B89 Standard. The tolerance is also displayed. According to the standard, if the center check is out of tolerance, it is recommended that the data be re-recorded. You may be able to retake one of the 2 center line segments to get it in tolerance. *See Page 42, Center-Line Tolerance Data Quality Check* for a procedure to retake a set of data for a line segment.

Step 3: Results

Results

Plate Grade: A
 Flatness (Max-Min): 500 ✗
 Tolerance: 400
 Units: µin
 X Dimension: 42.00
 Y Dimension: 30.00
 Line BF Center Value: 0 ✓
 Line DH Center Value: -50 ✓
 Center Intersection Tolerance: 100

Line Tables

Line AE			
Point #	Collected	Zero Line Ends	Zero at Center
1	-280	-280	310
2	-350	-400	190
3	-390	-490	100
4	-390	-550	40
5	-350	-590	30
6	-310	-570	20
7	-280	-580	10
8	-240	-590	0
9	-160	-560	30
10	-80	-530	60
11	-40	-550	40
12	0	-560	30
13	120	-490	100
14	260	-380	210
15	430	-280	310

Line GC			
Point #	Collected	Zero Line Ends	Zero at Center
1	-310	-310	510
2	-430	-460	370
3	-510	-560	270
4	-550	-620	210
5	-590	-680	150

Plane 6 also displays the data tables for each line segment. This is all displayed in the report.

Step 12 – Review Graphical Results in Step 4 3D Graph

You can go to *Step 4 3D Graph* to look at an adjustable 3d graph of the results. You can zoom in/out and rotate the view to see the results. You can also magnify the elevation change to better show the results.

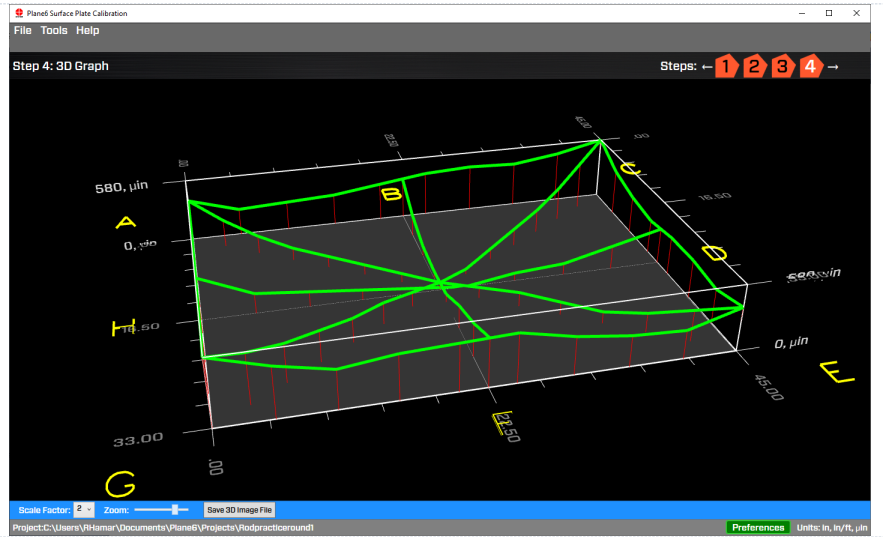

L-703SP - How to Do a Reverse Line Check

Using the A-703SP-LM-M

There are times when a surface plate is positioned against a wall or other obstruction, preventing the A-703SP-LM Laser Fixture from hanging off the plate, as is required. However, if you attempt to flip the standard A-703SP-LM Laser Fixture around, then it will set the border at least 3.5 in. from the edge, which is well outside the B89 Standard specification.

To solve this problem, Hamar Laser offers the A-703SP-LM-M, a “mirrored” version of the fixture (see page 11) that allows for the line to be reversed and the laser fixture to be positioned at the correct border spacing.

Here is a quick procedure to take data by reversing the line using the A-703SP-LM-M.

Step 1 – Select the Line Segment and Click Reverse

Select the line segment you want to use and find the *Reverse Direction* check box (lower right corner). If it is unchecked, then check it. In some cases (lines GE & AG), the box will already be checked. In this case, uncheck it. When checking or unchecking the box, you will see the target icon switch to the other end of the line, indicating where you should place the A-703SP-LM-M laser fixture.

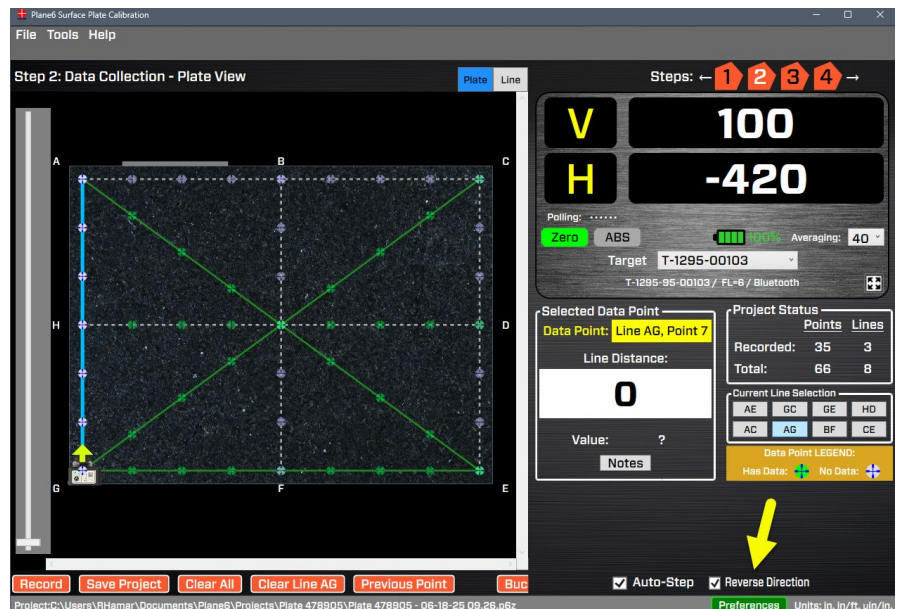

Step 2 – Set Straightedge Using Corner Locating Tools

Important! Select a straightedge that is the same or shorter than the line length minus 2x the border width.

For example, for a 36 in line segment and 1.5 in. borders, you need to use a straightedge that is $36 - (2 \times 1.5) = 33$ in. long or shorter. This is because the wall blocks one end of the straightedge, and the laser fixture blocks the other end.

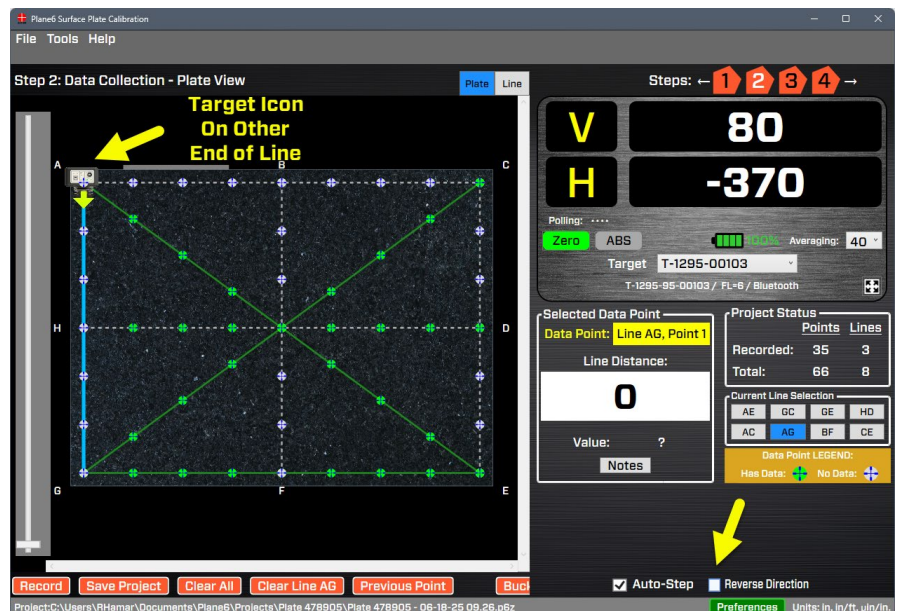

Step 3 – Use Corner Locating Tools to position the straightedge

Using the corner locating tools, place the straightedge on the plate as shown on Page 16 with one important difference: reverse the straightedge and place the *non-scale* side against the tool, as shown to the right.

Normal Setup for AG

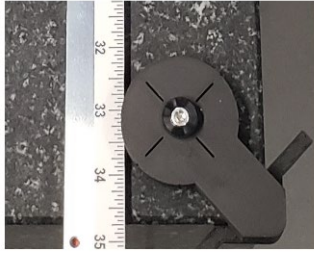

Reverse Setup for AG



Step 4 – Place the A-703SP-LM-M on the Straightedge

As shown on Page 47, place the A-703SP-LM-M Laser Fixture against the straightedge and align the end to the green line. The laser fixture, however, will be against the side of the straightedge without the scale.

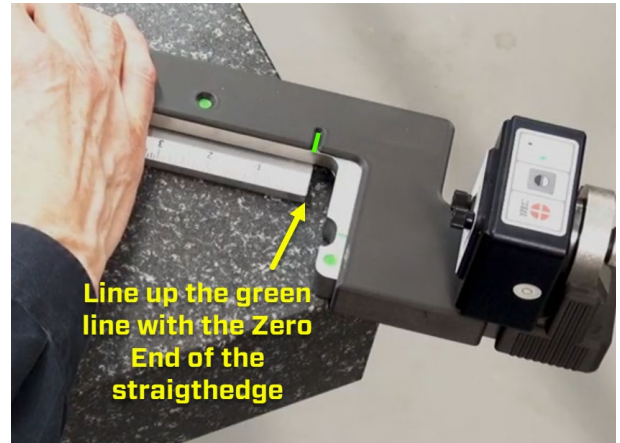

Step 5 – Take Data

As shown above, record the data points, but the target base will be on the other side of the straightedge, so it will be a little harder to line up with the correct point on the measurement scale.

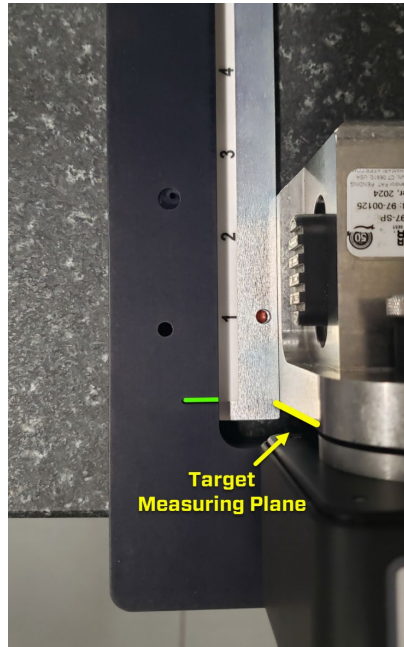

L-703SP - How to Take a Data Point without a Straightedge

Using the A-703SP-LM-M

In cases where you have to use a straightedge that is shorter than the line length, you will need to use the H axis on the readout to position the target:

1. Using a second straightedge that is longer than the remainder of the measurement line, line it up against the shorter straightedge.



2. Use the straightedge scale to locate the points that you need and put a mark against the side of the straightedge that is touching the shorter straightedge.

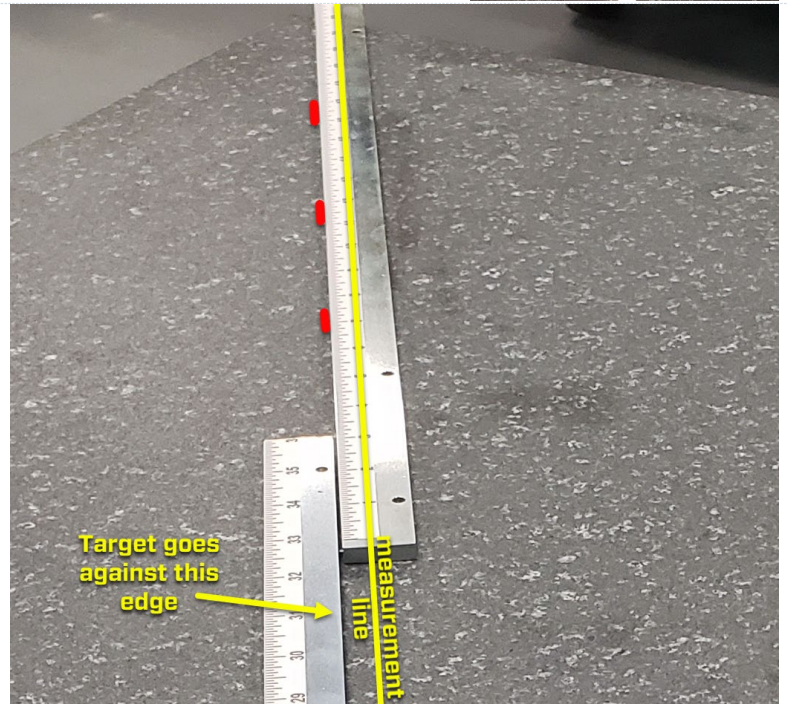

3. Record the data as normal for the points along the straightedge. After taking the last point, move the target to the first marked point, and align the edge of the A-1297-SP Target Base to the mark on the plate.

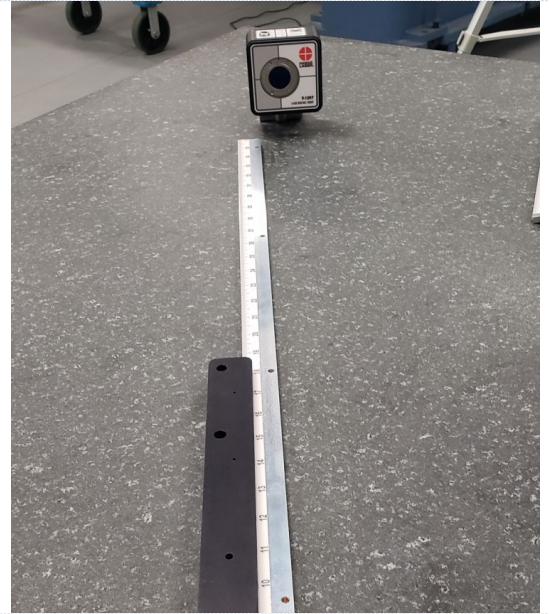

4. Looking at the H-Axis display, slowly slide the A-1297-SP left/right until the H-Axis display is less than 10,000 μin . (254 μm). Record the data point. Repeat this procedure for each marked point.

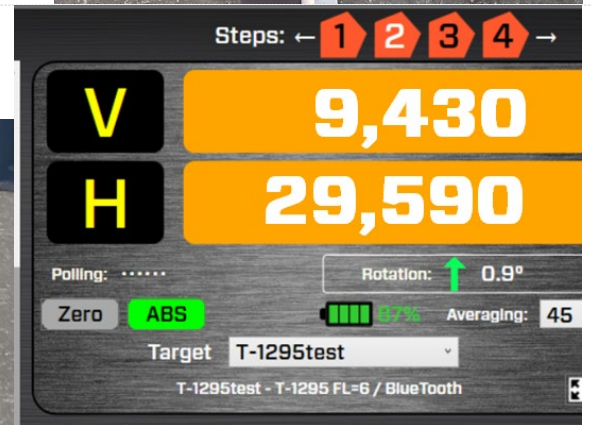
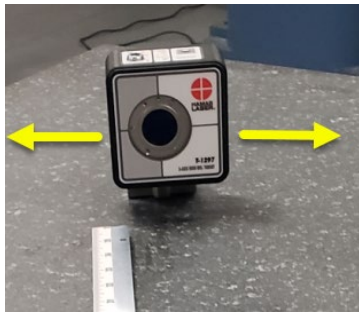

How It Works – Plane6 Step 2 - Line View

Performing a Flatness Quick-Check on a Line Segment after Lapping

One of the annoying parts of using electronic levels when resurfacing a surface plate is that you have to shoot the entire plate for flatness to see how the lapping process is going. This is a waste of time! With the L-703SP Surface Plate Calibration Systems, you can do quick checks of a single line segment in about 2-4 minutes to see how much the flatness error has been reduced. Typically, you'll pick the line segment with the highest flatness error and focus on it as you lap the plate.

To aid this process, we developed a second data-taking module (optional) called **Line View**. With **Line View**, you can select any line segment, which will bring the values from the plate data into the *Live View* data grid. You can then resurface the plate, clean it and measure the line to see how much improvement there is. You can record up to 5 sets of line data for each segment. You can also select more segments if you need to work on them, too.



Here is the procedure.

Note - you don't really need to clean the entire plate but just the area that you will measure.

Step 1 – Open Calibration File

If it is not already open, then open the calibration file for the plate you want to lap.

*Note – Since you will be recording new data for one or more line segments, it's good practice to protect the existing saved data by clicking on **Save New File for Existing Project** or **Save As New Project**. In this case, you want to **Preserve Save Data** when prompted, so it keeps all the data from your previous session..*

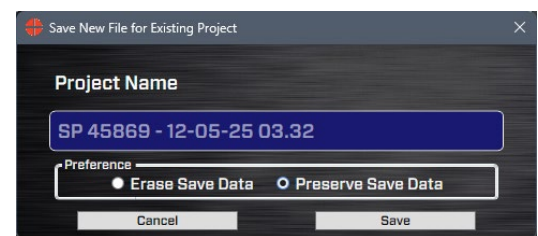
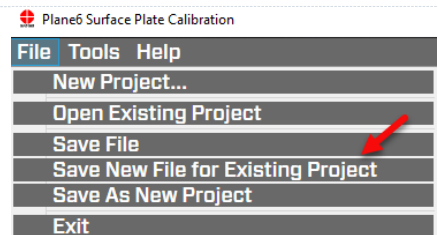

Step 2 – Open Step 2 and Select Line View Tab

Go to Step 2 and click on the **Line View Tab** at the top of the screen to open the screen.

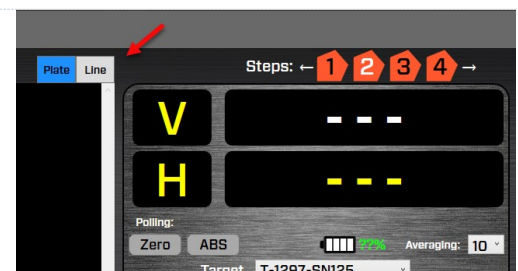

Step 3 - Select Line Segment & Set Up A-703SP-LM Laser Fixture

Select the line segment you want to measure by clicking on the segment letters in the **Current Line Selection** box. Then, select the matching length for the A-703SP-SE Straightedge ruler.

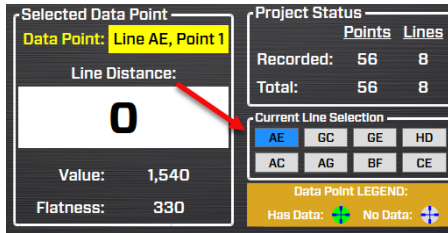

Use the corner/midpoint locating tool to set up the straightedge as shown above *on page 49*.

Then, place the L-703SP-LM Laser Fixture on the straightedge, as shown above. Don't forget to wait the time suggested. *See Figure 11*, before starting to record the data.



Step 4 – Buck-in the Laser

Before taking data, it's a good idea to make sure the laser is still reasonably parallel to the A-703SP-LM Laser Mount, just as shown in Steps 5a & 5b starting *on page 51*.

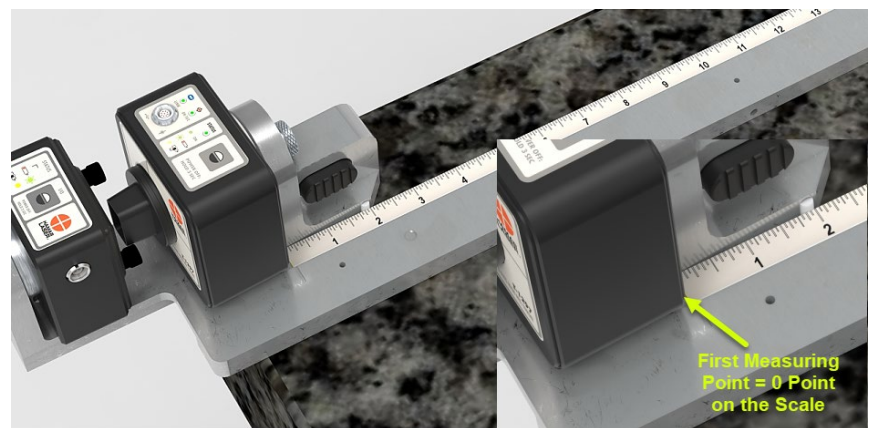

Step 6 – Click on *New* Button To Start

Click on the *New* button, which will enable the first empty row in the grid to record data. A “cursor” (the box will be highlighted) will appear at the first point in the row, which means it’s ready to take data.

Record New Clear Line Clear All Dump To Grid

Plane6 Surface Plate Calibration
File Tools Help

Step 2: Data Collection

AE	Point 1	Point 2	Point 3	Point 4	Point 5	Point 6	Point 7
Grid R	-130	-350	-380	-300	-140	-40	0
Grid C	0	-250	-300	-230	-100	-20	0
L1	R	--	--	--	--	--	--
	C	--	--	--	--	--	--
L2	R	--	--	--	--	--	--
	C	--	--	--	--	--	--
L3	R	--	--	--	--	--	--
	C	--	--	--	--	--	--

Cursor - means it's ready to record data

Step 7 – Record the Values

Place the target on the zero point on the scale. Click **Record** to record the value. Move the target to the next point on the scale by looking at the **Select Data Point** display to find the location on the measuring scale. Click **Record** and continue to record data until all the points are taken.

Selected Data Point

Data Point: Line AE, Point 2

Line Distance:

7 3/4

Value:

Flatness:

Step 8 – View Results

When you’re done recording the values for AE, you’ll see the raw data (R) in row L1 and the corrected data (C), where the endpoints are zeroed and the max value represents the overall flatness error for the segment. In the example to the right, the max value is 240 μm .

The data is plotted in the graph below, along with the plot for the original data set. The plots are color-coded to match the Row color.

Record New Clear Line Clear All Dump To Grid

Plane6 Surface Plate Calibration
File Tools Help

Step 2: Data Collection

AE	Point 1	Point 2	Point 3	Point 4	Point 5	Point 6	Point 7
Grid R	-130	-350	-380	-300	-140	-40	0
Grid C	0	-250	-300	-230	-100	-20	0
L1	R	150	150	380	160	280	170
	C	0	0	240	10	130	20
L2	R	--	--	--	--	--	--
	C	--	--	--	--	--	--
L3	R	--	--	--	--	--	--
	C	--	--	--	--	--	--
L4	R	--	--	--	--	--	--
	C	--	--	--	--	--	--
L5	R	--	--	--	--	--	--
	C	--	--	--	--	--	--

Cursor - means it's ready to record data

Steps: 1 2 3 4

V 120
H -190

Zero ABS

Target T-1295-103

Selected Data Point
Data Point: Line AE, Point 7
Line Distance:
55 13/16
Value: 140
Flatness: 240

Project Status
Points 8
Recorded: 56
Total: 56

Current Line Selection
AE GC GE HD
AC AG BF CE

Line Chart Visibility
 Grid Values Revision L1 Revision L2
 Revision L3 Revision L4 Revision L5

Auto-Step Reverse Direction

Project: C:\Users\Bhamar\Documents\Plane6\Projects\New Fixt - plate test - 40 ave - new laser\New Fixt - plate test - 40 ave - new laser - 02-04 - Preferences Units: in, in/ft, µm/in

Step 9 – Continue to Lap and Record Data

If the first run at lapping (resurfacing) the plate did not help the plate to pass calibration, then you can lap it again and then record a new set of line data for a given line segment. For example, if the calibration spec for the plate is 800 μm . and the max value in the recorded set of line data is 950 μm ., then you need to continue to lap the plate until it is significantly lower than 800 μm .

To record a second set of data, click on the **New** button, which will enable the next available row to record data. Then, as before, click on *Record* to record the data. You will notice the data will start filling into the second row, L2. When you're done, as before, it will calculate the corrections and display the results in row C. The graph will also show the line graph for the new set of data.



Step 10 – Add New Data back into Plate Data

If you are satisfied with the results, you can pick another segment to work on, or you can use **Dump to Grid**, which will automatically upload the new data into the **Grid** row in **Line View**. It will also automatically upload the new data into Plate View (replacing the old data). If you go to Step 3 Results and view the data table for the line segment, you will see the newly recorded data. Now, you can see how that new line of data affected the overall flatness of the plate.

To use **Dump to Grid**, you must first click on the row (click on L1, L2, etc.) to highlight it and then click on **Dump to Grid**. You will notice the white graph disappears as this was the “old” data and has now been replaced by the set of data that you selected.

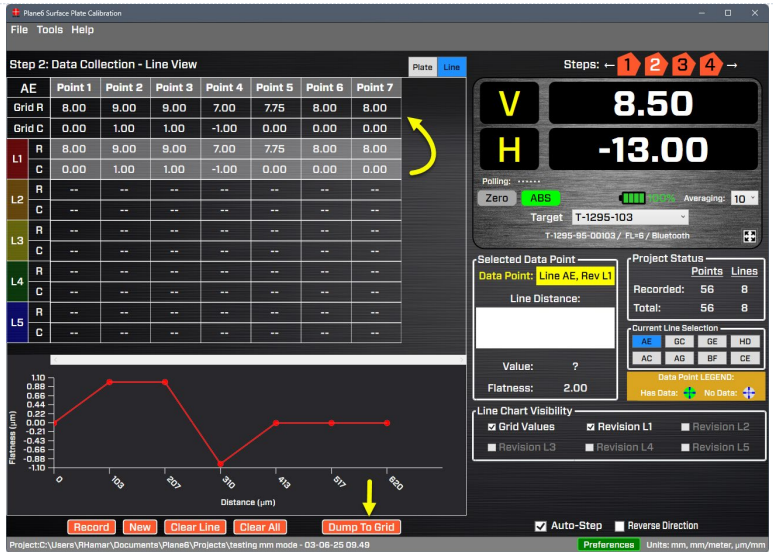

Step 11 – Record Values for Other Line Segments

By clicking on another line segment in the **Current Line Selection** box, you can take data for that segment by following the steps above.

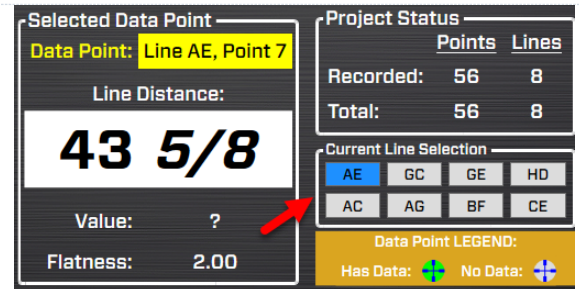

Printing the Report

To print a report of the calibration, go to Step 3 and find the print button at the bottom.

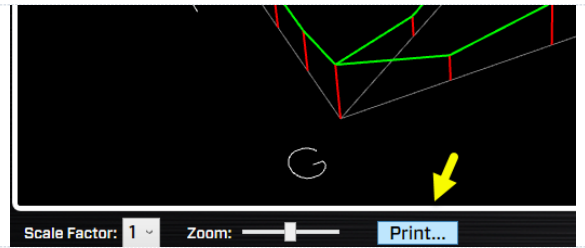

The usual print dialog box will open and you can select the printer or print to PDF.

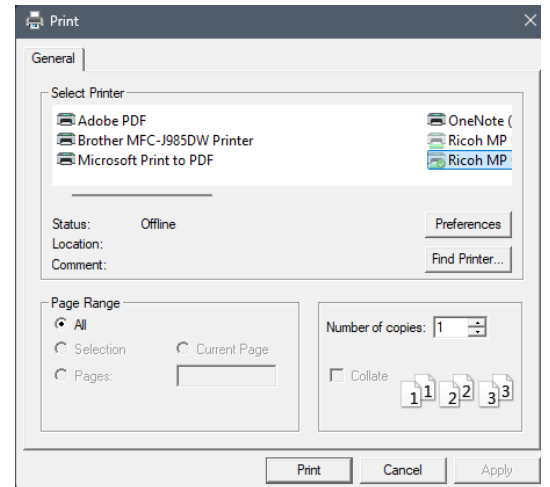

Plane6 Sample Report



Plane6
Repeat_3 Results

Plate Grade: B
Flatness (Max-Min): 440 X
Tolerance: 200
Units: μ m

X Dimension: 39.13
Y Dimension: 27.13

Line BF Center Value: -10 ✓
Line DH Center Value: -10 ✓
Center Intersection Tolerance: 100

Plate Serial Number: 7490-89R
Technician Name:
Contact Info:
Recording Date:
Recording Time:
Temperature (Top): 72.4
Temperature (Bottom): 74.8
Project Notes:

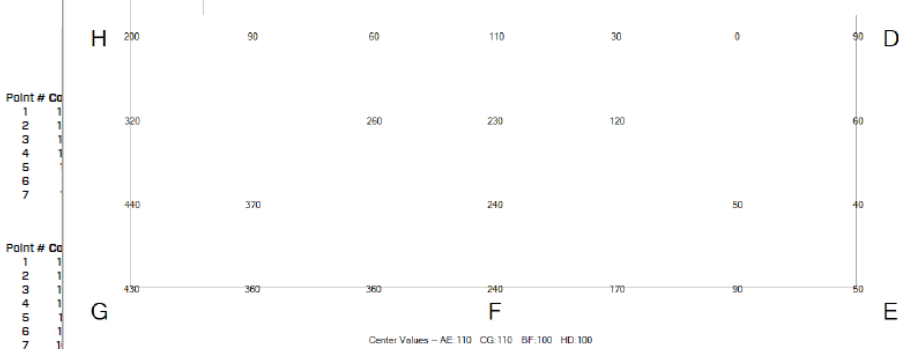
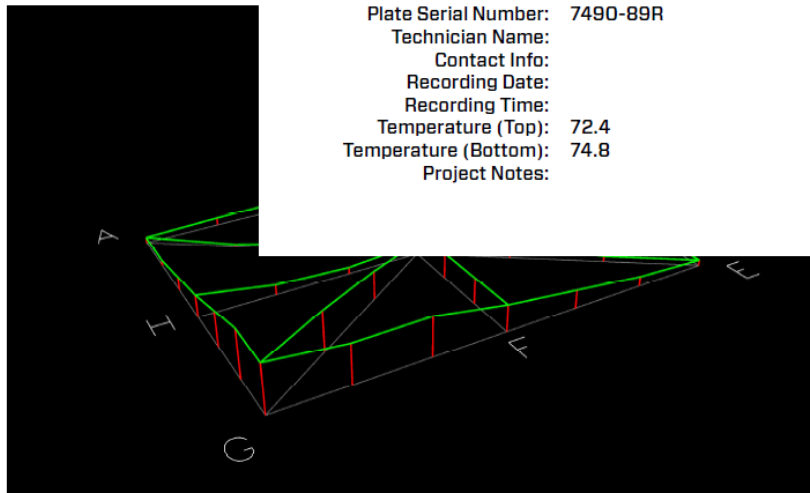

Point # Co
1 1
2 1
3 1
4 1
5 1
6 1
7 1

Point # Co
1 1
2 1
3 1
4 1
5 1
6 1
7 1

Line HD

Point #	Collected	Ends to Outer Center	Zero Low Point
1	10,750	90	200
2	10,630	-20	90
3	10,590	-50	60
4	10,630	-10	100
5	10,550	-80	30
6	10,510	-110	0
7	10,590	-30	90

Line BF

Point #	Zero Line Ends	Ends to Outer Center	Zero Low Point
1	10,710	50	160
2	10,630	-60	50
3	10,670	-50	60
4	10,750	-10	100
5	10,910	120	230
6	10,940	120	240
7	10,980	130	240

Appendix A – Installing Additional Microsoft Software

Installing Microsoft .NET Framework 4

You must have Microsoft .NET Framework installed before installing the Plane6 software. If you are unsure whether you have Microsoft .NET Framework 4 installed on your computer, open the Control Panel. Window 7 users, select **Programs and Features**. Scroll down the list of installed software to locate Microsoft .NET Framework 4. If the program is not installed, follow the instructions below. Windows 10 & Windows 11, Microsoft .Net is preinstalled and user should not need to install. Follow steps below if .Net is missing from computer.

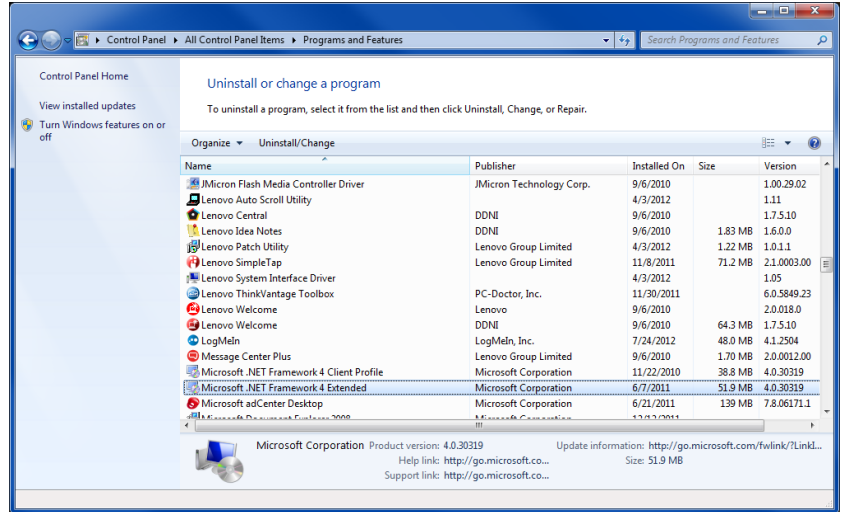

1. To install Microsoft .NET Framework 4, locate the folder **MS_Framework_4_X86_X64** on the Plane6 installation USB drive. Open the folder and double-click **DOTNETFX40_FULL_X86_X64** to begin the installation. Follow the on-screen prompts to complete.

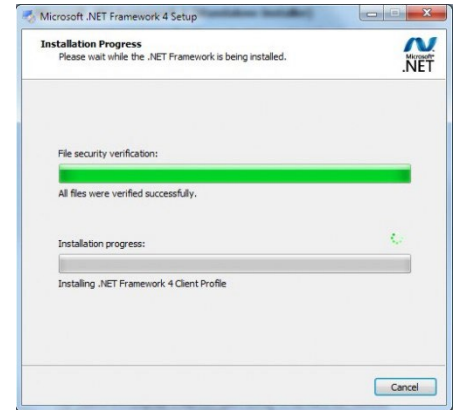

2. When the installation is complete, click **Finish** to close the installation program.

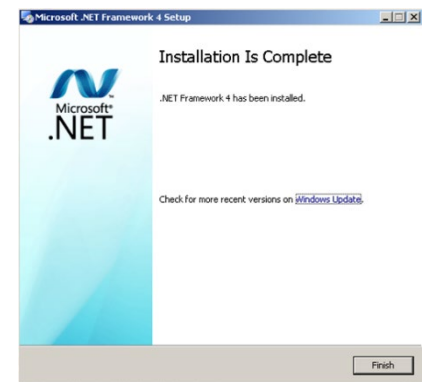

Appendix B – ANSI B89.3.7.2013 Standard Tolerance Table

Plane6 Software uses the tolerances for the standard plate sizes shown in Figure 29 below from the ANSI B89.3.7.2013 Standard for Granite Surface Plates.

For non-standard sizes, we use the formula from the standard:

“Flatness tolerance for surface plates, whose sizes are not listed in Table 1, is obtained from the following formula:

$$\text{Overall flatness tolerance } (\mu\text{m}) = 1 + 1.6 \cdot D^2$$

$$\text{Overall flatness tolerance } (\mu\text{in.}) = 40 + D^2/25$$

Where,

D = diagonal or diameter of the plate

The calculated flatness tolerance for grade AA is rounded up to the nearest 0.5- μm or 25- $\mu\text{in.}$ increment. The tolerance of grades A and B plates are 2 and 4 times, respectively, those for grade AA.”

Table 1 Common Sizes and Flatness Tolerances

Common Sizes Rectangular Surface Plates				Tolerance											
				Grade AA				Grade A				Grade B			
U.S. Customary Size, in.		Metric Size, mm		Local Variation in Flatness (Using Repeat Reading Gage)		Overall Flatness		Local Variation in Flatness (Using Repeat Reading Gage)		Overall Flatness		Local Variation in Flatness (Using Repeat Reading Gage)		Overall Flatness	
Width	Length	Width	Length	U.S. Size, $\mu\text{in.}$	Metric Size, μm	U.S. Size, $\mu\text{in.}$	Metric Size, μm	U.S. Size, $\mu\text{in.}$	Metric Size, μm	U.S. Size, $\mu\text{in.}$	Metric Size, μm	U.S. Size, $\mu\text{in.}$	Metric Size, μm	U.S. Size, $\mu\text{in.}$	Metric Size, μm
12	12	300	300	35	0.9	50	1.3	60	1.5	100	2.5	110	2.8	200	5
12	18	300	450	35	0.9	50	1.3	60	1.5	100	2.5	110	2.8	200	5
18	18	450	450	35	0.9	50	1.3	60	1.5	100	2.5	110	2.8	200	5
18	24	450	600	35	0.9	80	2.0	60	1.5	160	4.0	110	2.8	320	8
24	24	600	600	45	1.2	80	2.0	70	1.8	160	4.0	120	3.0	320	8
24	36	600	900	45	1.2	100	2.5	70	1.8	200	5.0	120	3.0	400	10
24	48	600	1 200	45	1.2	150	4.0	70	1.8	300	8.0	120	3.0	600	16
30	48	750	1 200	45	1.2	180	4.5	70	1.8	360	9.0	120	3.0	720	18
36	36	900	900	45	1.2	150	4.0	70	1.8	300	8.0	120	3.0	600	16
36	48	900	1 200	45	1.2	200	5.0	70	1.8	400	10.0	120	3.0	800	20
36	60	900	1 500	60	1.5	250	6.5	80	2.0	500	13.0	160	4.0	1,000	26
36	72	900	1 800	60	1.5	300	7.5	80	2.0	600	15.0	160	4.0	1,200	30
48	48	1 200	1 200	60	1.5	200	5.0	80	2.0	400	10.0	160	4.0	800	20
48	60	1 200	1 500	60	1.5	300	7.5	80	2.0	600	15.0	160	4.0	1,200	30
48	72	1 200	1 800	60	1.5	350	9.0	80	2.0	700	18.0	160	4.0	1,400	36
48	96	1 200	2 400	75	1.9	500	13.0	100	2.5	1,000	26.0	200	5.0	2,000	52
48	120	1 200	3 000	90	2.3	700	18.0	120	3.0	1,400	36.0	240	6.0	2,800	72
60	120	1 500	3 000	90	2.3	750	19.0	120	3.0	1,500	38.0	240	6.0	3,000	76
72	96	1 800	2 400	90	2.3	600	15.0	120	3.0	1,200	30.0	240	6.0	2,400	60
72	144	1 800	3 600	100	2.5	1,100	28.0	140	3.5	2,200	56.0	280	7.0	4,400	112

Round Surface Plates Diameter		Round Surface Plates Local Variation in Flatness (Using Repeat Reading Gage)		Overall Flatness		Round Surface Plates Local Variation in Flatness (Using Repeat Reading Gage)		Overall Flatness		Round Surface Plates Local Variation in Flatness (Using Repeat Reading Gage)		Overall Flatness	
U.S. Customary Size, in.	Metric Size, mm	U.S. Size, $\mu\text{in.}$	Metric Size, μm	U.S. Size, $\mu\text{in.}$	Metric Size, μm	U.S. Size, $\mu\text{in.}$	Metric Size, μm	U.S. Size, $\mu\text{in.}$	Metric Size, μm	U.S. Size, $\mu\text{in.}$	Metric Size, μm	U.S. Size, $\mu\text{in.}$	Metric Size, μm
12	300	35	0.9	50	1.3	60	1.5	100	2.5	110	2.8	200	5
18	450	35	0.9	50	1.3	60	1.5	100	2.5	110	2.8	200	5
24	600	35	0.9	80	2.0	60	1.5	160	4.0	110	2.8	320	8
36	900	45	1.2	100	2.5	70	1.8	200	5.0	120	3.0	400	10
48	1 200	45	1.2	120	3.0	70	1.8	240	6.0	120	3.0	500	12

GENERAL NOTES:

- (a) Dimensions of length and width for common sizes are nominal dimensions only. The tolerances in this Table apply to sizes within $\pm 5\%$ of the nominal sizes listed. For guidance on recommended tolerances on sizes outside the listed common sizes, see para. 4.3.4.1. For flatness tolerances on surface plates not covered explicitly by this Standard, it is recommended that the manufacturer and buyer agree on the expected tolerance before a contract is concluded.
- (b) For granite reference flats smaller than the sizes listed above (commonly known as “toolmakers’ flats”), consult the manufacturer for tolerances supplied.

Figure 29 - ANSI B89.3.7.2013 Flatness Tolerance Table

Appendix C -Troubleshooting Guide

Problem	Solution	Reference Page Number
No laser beam	<ul style="list-style-type: none"> • Make sure the laser is turned on/ • Make sure the laser is charged up. <ul style="list-style-type: none"> ○ Make sure laser charger is working properly. Test with voltage tester. • If the Laser-On LED is turned on but there is no visible beam, then call our Support line as this probably means the laser has failed. 	<p>3 3 3 3</p>
Cannot adjust laser beam to center of target	<ul style="list-style-type: none"> • Make sure that the A-703SP-LM Fixture and the A-1297-SP Target Measuring Base are pushed up against the A-703SP-SE Straightedge • Make sure the adjustment knobs are not turned all the way in or out. 	<p>4</p>
No readings in Plane6 software data displays	<ul style="list-style-type: none"> • Make sure the laser is turned on and/or charged. • Make sure the laser is in Double-Blink Mode • Make sure the target is turned on. <ul style="list-style-type: none"> ○ Is the target status LED turned on? ○ Make sure it's charged up. Is the battery status LED blinking? • Make sure the correct target is selected in the dropdown list in Step 2. • Is the T-1297 Target paired with the computer? • Is the computer's Bluetooth radio turned on? See Windows help for more details. 	<p>3 3 5 33 7-8, 32</p>
Poor repeatability	<ul style="list-style-type: none"> • Make sure the laser and target fixtures have acclimated to the temperature for at least one hour • Make sure the laser and target have been turned on for at least 30 minutes. • Make sure the laser window and target windows are clean. • Make sure the surface plate is properly cleaned • Make sure the laser and target thumb screws are firmly tightened. • Make sure the A-1297 measuring base's measuring feet are clean • Make sure the surface plate is stable. <i>Note: it takes 1-5 hours (in some cases up to 24 hours) for a surface plate to stabilize after a significant temperature change or a movement of the base that it sits upon (i.e., rolling it on a cart without a 3-point mount).</i> 	<p>15</p>

Noisy Readings	<ul style="list-style-type: none"> • Check for sources of hot or cold air blowing onto the surface plate. <ul style="list-style-type: none"> ○ Try to block the air if possible. ○ Up the averaging in Step 2 Data display. • Check for blinking lights or safety lights • Make sure the fixtures, laser and target are properly warmed up and “soaked in” to the ambient temp. 	
Laser won’t charge up	<ul style="list-style-type: none"> • Check to make sure the A/C adapter is working properly. Use a voltage tester. <i>Note - when the target is fully charged, the Status LED is turned off. However, if you plug in the charger, you will see the LED blink once, which indicates the charging is complete.</i> 	3-4
Target won’t charge up	<ul style="list-style-type: none"> • Check to make sure the USB charger A/C adapter is working properly. Use your cell phone charger to test it. • <i>Note - when the target is fully charged, the Status LED is turned off. However, if you plug in the charger, you will see the LED blink once, which indicates the charging is complete.</i> 	6
I don’t see the flatness results in Step 3	<ul style="list-style-type: none"> • Make sure all the data values have been recorded in Step 2. Plane6 cannot complete the calculations unless all the values are recorded. 	36-37
My data displays are orange, why?	<ul style="list-style-type: none"> • Plane6 puts a tolerance on the raw values in Step 2 to keep the laser beam on the most accurate part of the PSD sensor. This means you need to adjust the pitch and/or yaw knobs on the laser to bring it back to the accurate part of the PSD. Also check to make sure the A-703SP-LM laser fixture is pushed up against the straightedge. 	30
The last point on the diagonal line is too near the plate edge or is off the edge.	<ul style="list-style-type: none"> • Make sure the dimensions entered in Step 1 match the actual plate dimensions. • Make sure the border dimension in Step 1 matches the Corner Locating Tool 	34-35 15-16
The measurement line is not 1.5 or 2.0 in. from the plate edge.	<ul style="list-style-type: none"> • Make sure the straightedge was installed correctly with the corner locating tools. Remember that the scale side always touches the corner-locating tool. 	13-14

Appendix D - How to Calibrate the T-1297 Target

Using the A-808-1297-DM

Here is a summary of the procedure to calibrate the T-1297 3-Axis Target using the A-808-1297-DM and detailed in the *A-808-1297-DM Manual*. This summary uses microinches but the manual uses decimals. Please see the *A-808-1297-DM Manual* for details on how to set up the A-808 fixture and for a procedure on how to calibrate the T-1297 Target.

Note – you will not need to check the calibration for the horizontal axis of the target, which is not calibrated for this application. Only the vertical axis is calibrated.

Step 1 – Fixture Temperature

Let the A-808-1297-DM Calibration Fixture “soak” in the ambient temperature for at least 1 hour for a temperature differential of <math><5^{\circ}</math> F. For 5-10° F temperature differentials, soaking 2 hours is best. Over 10° F, 3+ hours is best.

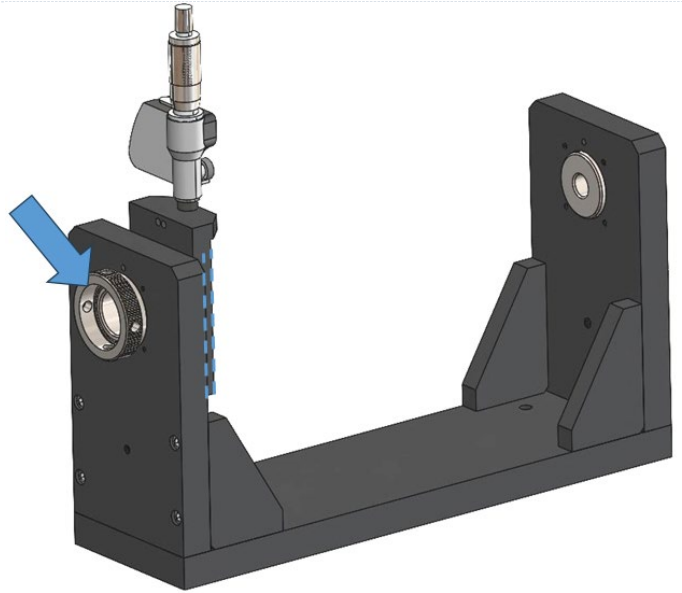

Step 2 – Laser & Target Warmup

Turn on the laser and target and let them warm up for at least 30 minutes. Turn on the digital micrometer

Step 3 – Install Laser & Target

Install the L-703S Laser on the non-moveable side of the A-808-1297-DM. Make sure to line it up parallel with the top of the fixture and tighten using the provided Thumb Screw. This orients the Pitch and Yaw adjustments with the X & Y axes of the target. It’s not overly critical but just good practice.

Tighten the thumb screw or set screw very tight.

Insert the T-1297’s mounting stud into the .500 in. mounting hole on the side of the fixture with the micrometer and tighten the set screw.

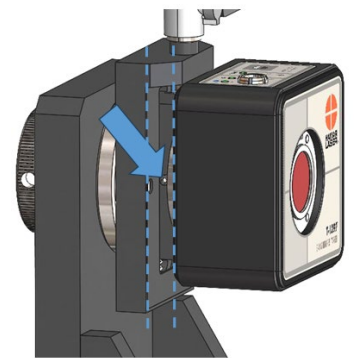
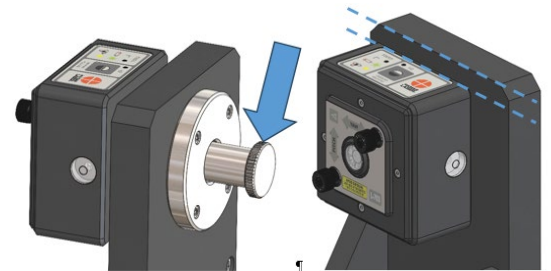

Step 4 – Open Plane6 and Zero the Display

Open a file in Plane6 and go to Step 2. Set the *Averaging* to 80. With the display in ABS Mode, adjust the Micrometer until the V Axis reads zero.

Note it will be difficult to get to zero down to 10 μ m. (0.25 μ m), so get it as close as you can.

Now click on the **Zero** button to zero the display. Also, zero the micrometer. Make sure the micrometer has 5 digits.



Step 5 – V^{POS} - Turn Micrometer +.02500 in.

Turn the micrometer to exactly +.02500 (5 digits). Write down what the V-axis Display reads. In this case, $V^{POS} = 24,760$.

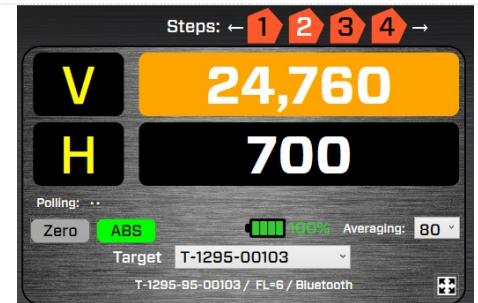

Step 6 - V^{NEG} - Turn Micrometer -.02500 in.

Return the micrometer to zero and zero the display if necessary. Turn the micrometer to exactly -.02500. Write down what the V-axis Display reads. In this case, $V^{NEG} = -26,690$.

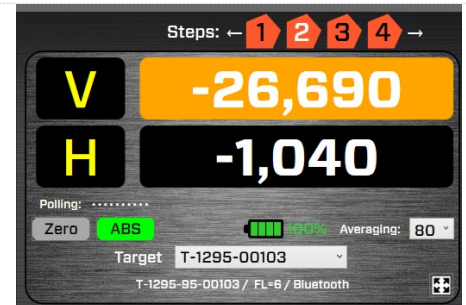

Step 7 – Find Current Calibration Factors

Open Preferences, click on Targets and then click on the target serial number you want to calibrate. Click Edit Target.

Note – you can have many targets listed here, so make sure the serial number in the target record matches the serial number on the target.

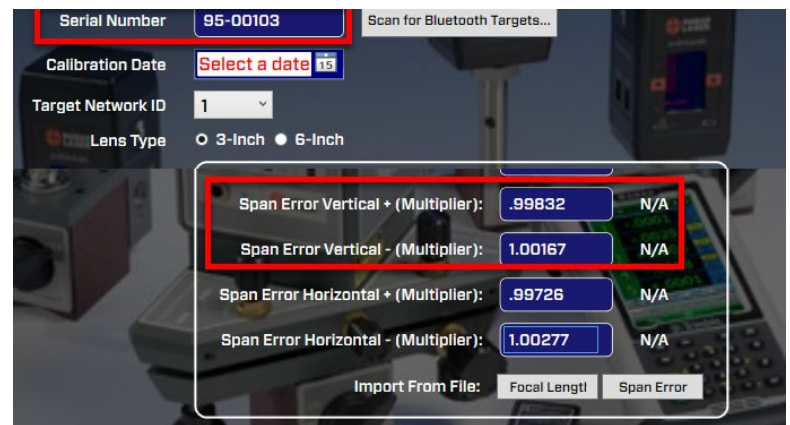
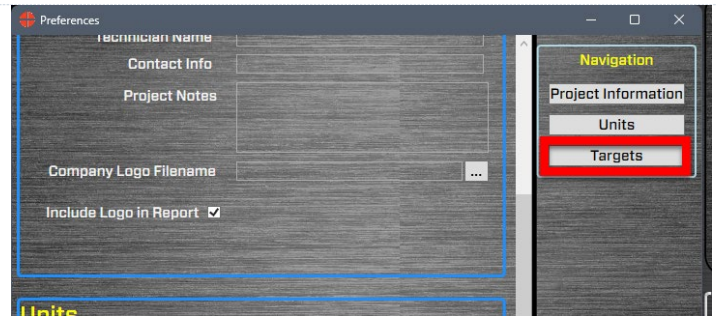

Step 8 – Calculate Calibration Factors - V^{POS}

Find the *Span Error Vertical+* calibration parameter from Preferences. We first have to undo the old calibration factor:

$$\text{Raw } V^{POS} = V^{POS} / \text{OCF}$$

Where:

V^{POS} = the display value after the micrometer move (MMV) from above
 OCF = Old Cal Factor that was entered into Preferences for that target (see the image)

$$V^{POS} = 24,760$$

$$\text{OCF } V^{POS} = 0.99832$$

$$\text{Raw } V^{POS} = 24,760 / 0.99832 = 24,801$$

Now we take the MMV and divide by the Raw V^{POS} to get the new New Cal Factor

$$25,000 / 24,801 = 1.00802$$

Enter 1.00802 into *Span Error Vertical +*

Step 9 - Calculate Calibration Factors - V^{NEG}

Find the *Span Error Vertical*- calibration parameter from Preferences. Again, we have to undo the old calibration factor:

$$\text{Raw } V^{NEG} = V^{NEG} / \text{OCF}$$

Where:

V^{NEG} = the display value after the MMV from above

OCF = Old Cal Factor that was entered into Preferences for that target (see the image)

$$V^{NEG} = -26,690$$

$$\text{OCF } V^{NEG} = 1.00167$$

$$\text{Raw } V^{NEG} = |-26,690 / 1.00167| = 26,734$$

Now we take the MMV and divide by the Raw V^{NEG} to get the new New Cal Factor

$$25,000 / 26,734 = .93513$$

Enter .93513 into *Span Error Vertical* -

Step 10 – Enter Calibration Factors

Enter the calibration factors into the matching *Span Error Vertical (Multiplier)* entry box. The first box is for the $V^{POS} \pm$ factor and the second is for the V^{NEG} (-) factor.

Click **OK** to save them.

Note 1– the calibration values may not exceed 1.2 or be below 0.8. If the test produces a number outside this range, then redo the procedure. If the second cal check results in the same value, then contact support for help.

Note 2 – you can calibrate the Horizontal axis but since it is not a measuring axis, it is not required to calibrate it.

To calibrate the H axis, you must rotate the target to the Left 90 degrees (looking into the target). See the A-808-1297-DM manual for more details.

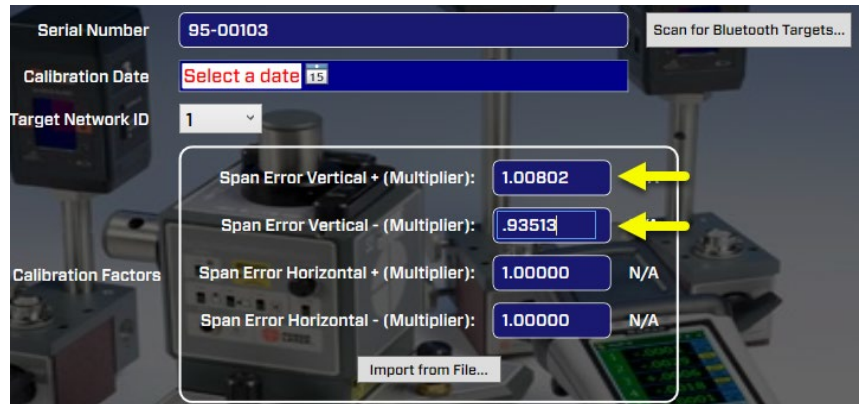

Step 11 – Calculate Residual Calibration Error

Repeat Steps 4 and 5 to verify the calibration factors are correct. Note the results.

The Residual Span Error formula is

$$RE = (MMV - Actual)/MMV$$

Where:

MMV = Micrometer Move (usually .02500 in.)

Actual = the display value after turning the micrometer

The Span Error Specification for the T-1297 target is **|Span Error|<0.25%**.

If the target fails the specification, you can restart the process and try again. Due to the small tolerance and some variability in the process, it can take a few tries.

Some tips:

- *Clean the target window and laser window with alcohol.*
- *Make sure the laser/target mounting screws are tight.*
- *When turning the micrometer, make sure it doesn't feel loose. If so, tighten the set screw. The micrometer should not wiggle.*
- *Due to backlash, it is always best practice to turn the micrometer in the same direction. Say you go from zero to .02680, you should not just turn the mic back to .02500. You should go past .02500, to say .02300, and then go to .02500.*
- *Do Not touch the A-808-1297-DM Fixture during the calibration process. The heat from your hand can cause the fixture to grow thermally and lead to excess errors.*

If, after a few tries, it still fails calibration and you have tried the remedies, then call our sales department (203-730-4600, sales@hamarlaser.com) to request an RMA and make a repair reservation.

Residual Span Error Example:

Sample Results from the Step 5 procedure after entering new calibration factors

$$V+ \text{ Actual} = 24,980$$

$$V- \text{ Actual} = -25,030$$

$$\text{Span Error } V+ = (25,000 - 24,980)/25000 = .0008 \text{ (0.08\%)}$$

$$\text{Span Error } V- = (-25,000 - -25,030)/25000 = -.0012 \text{ (0.12\%)}$$

Specification: |V| <0.25%

Both axes are “In Spec”