

Application Note

How It Works - Surface Plate Calibration

System Recommendation

L-703SP Surface Plate Calibration System

The setup and use of an L-703SP Surface Plate Calibration System is quite easy. The L-703S Laser is attached to the L-703SP-LM Laser Mounting Fixture that sits right on the plate. The A-703SP-SE Straight Edge is aligned to the line segment using a corner/midpoint locating tool and the T-1297 Target runs along the straight edge to keep it on the line segment when taking data. The laser is quickly aligned to the straightedge, which holds its alignment for the next 7 segments, so there is very little setup each time the laser fixture is moved to another segment.

To start the check, Plane6 is opened to Step 1 Surface Plate Layout and the relevant parameters are entered, such as the plate dimensions, number of points on each segment, and the plate's grade tolerance, etc.

Next, we go to Step 2, Data Collection and place the T-1297 target at the far point on the straight edge. Looking at the real-time display, the laser beam is tilted so the values are near zero, which aligns the laser to the straight edge. The laser is now ready to take data.

The target moved to the first point (next to laser) on the straight edge and the data is then recorded. The dimension on the ruler for the next point is then displayed in on the screen to aid in the positioning of the target. This process is repeated for all 8 line segments and the results are calculated using the Moody Method per the ASME-B89.3.7 Standard for calibrating surface plates.

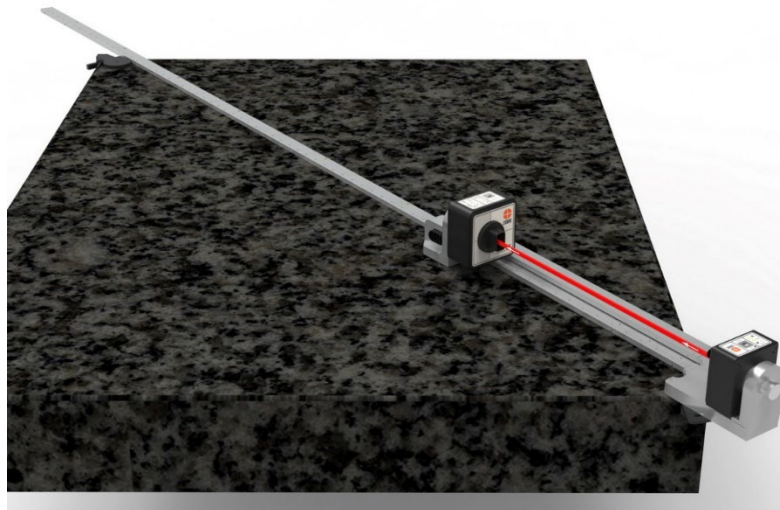

Below is a step-by-step procedure for checking the calibration of a surface plate with the L-703SP and Plane6 Software.



Hamar Laser Instruments, Inc.
5 Ye Olde Road Danbury, CT 06810 Phone:
800.826.6185 Fax: 203.730.4611
Int'l: +1.203.730.4600
E-mail: sales@hamarlaser.com www.hamarlaser.com [Click here](#)
for a list of our distributors.



L-703SP Surface Plate Calibration Procedure Using Plane6 Software

Step 1 – Assemble Laser and Laser Mount

Insert the L-703S Laser into the L-703SP-LM Laser Mounting Fixture and tighten the thumb screw very tight, making sure the top of the laser is level. Turn on the laser and let it warm up.

Note: we recommend a 30-minute warmup period

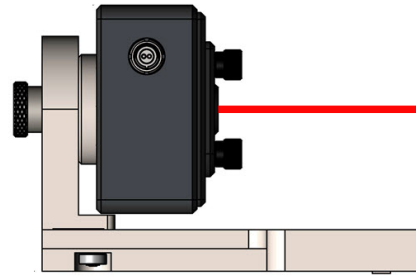

Step 2 – Plate Setup

These parameters need to be entered:

- the plate border size,
- the plate grade,
- the plate size in X & Y,
- the number of points to measure for the horizontal, vertical and diagonal line segments,
- pick the label location (optional),
- the plate serial number,
- the temperature for the top and bottom of the plate (optional), and
- the alignment tolerance.

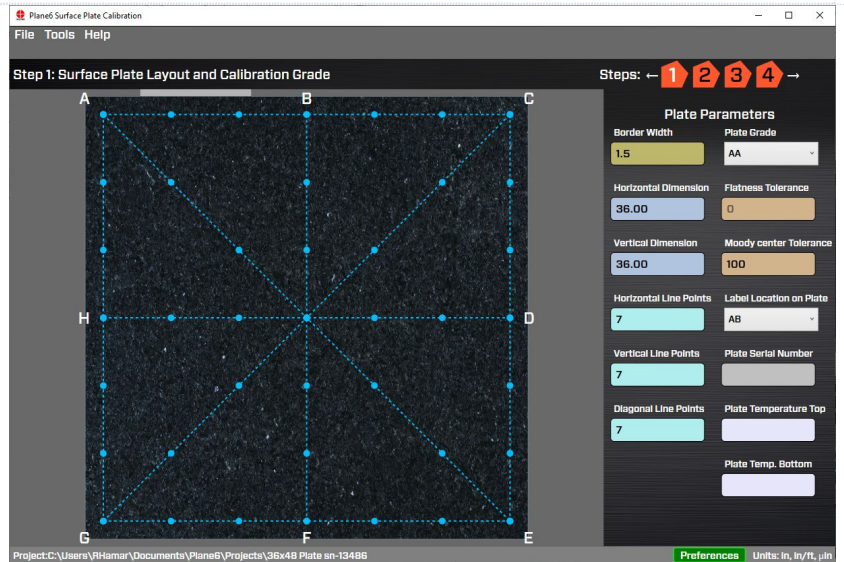

Step 3 – Use Corner/Mid-Point Locating Tool to Mark Mid-Points

A corner-locating tool is supplied to create the proper border width and help align the straight edge to the line segment on the plate, speeding up the process.

Place the Corner Marker on the corner and slide the Disc against it. Press the disc down to stick it to the plate and remove the Corner Marker.

Note – We supply a 1.5 in. corner tool, but we can make up different sizes if desired (2.0 in. or 2.5 in.).

Enter the border-width value for the tool in Border Width in Plane6 Step 1.

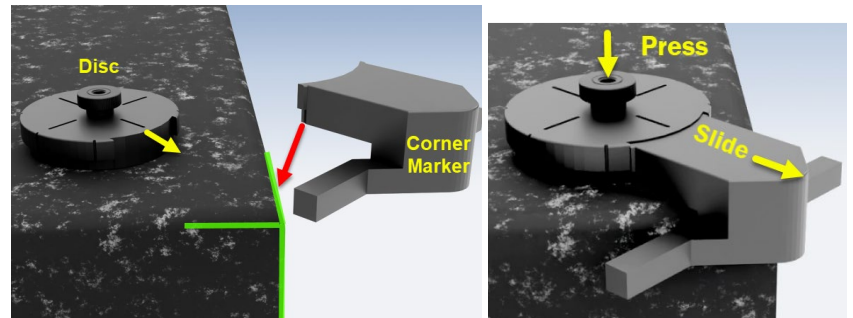

- Use a tape measure to mark the midpoints for each perimeter segment line, using the locating tool to show you where to make the mark.
- Do this for all 4 outside line segments.

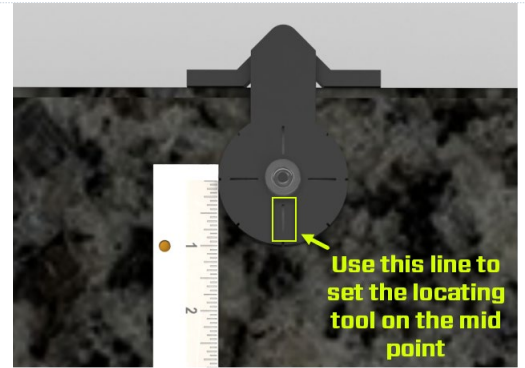

Step 4 – Place Straight Edge on the Diagonal Segment

Plane6 preselects the line sequence that you will measure. This can be overridden but this sequence was selected to minimize the time it takes to collect all the data. To measure the diagonal:

- Locate the first diagonal segment as recommended by Plane6, using the plate label location to orient yourself.

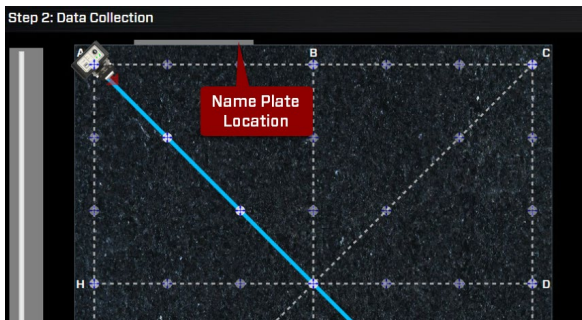

- Attach the Corner Marker and Disc on both ends of the line segment. Press down on the disc and remove the Corner Marker.

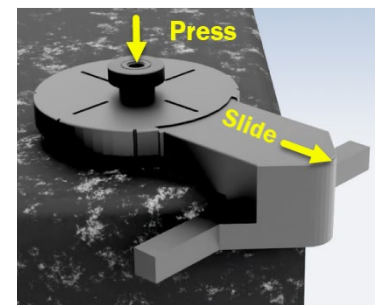
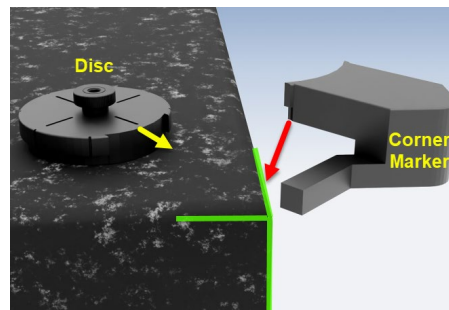

- Place the side of the straight edge with the ruler so it is touching the corner locator. See image. In general, you always want the *scale side* of the ruler to be touching the locator tool.
- Position the zero end of the straight edge to line up with the line on the rotating-edge-alignment tool – see image.
- Place the far end of the straightedge against the far disc.
- Now the straight edge is located next to the line segment that you need to measure, so that when the target is put down against the straight edge, it is directly over the line segment.
- Remove the discs.

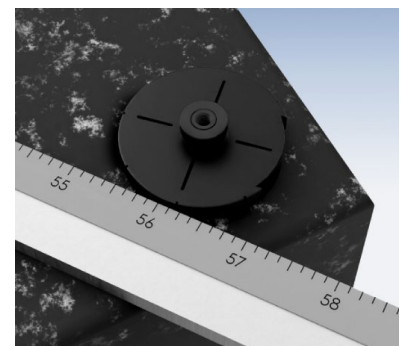
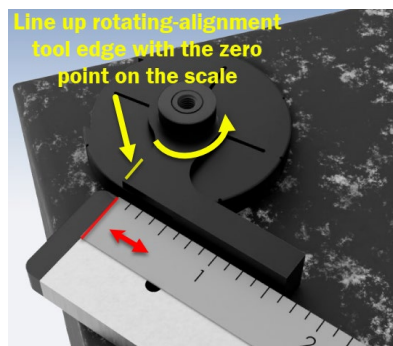

Step 4a –Place L-703SP-LM Laser Mount on top of the straight edge

- a. Place the A-703SP-LM Laser Fixture and L-703S Laser on the zero end of the straightedge. You can see which end to place the fixture by looking at Step 2 Measure Screen and finding the target icon, keeping track of the name plate location. Normally, this is on line AE. See image.

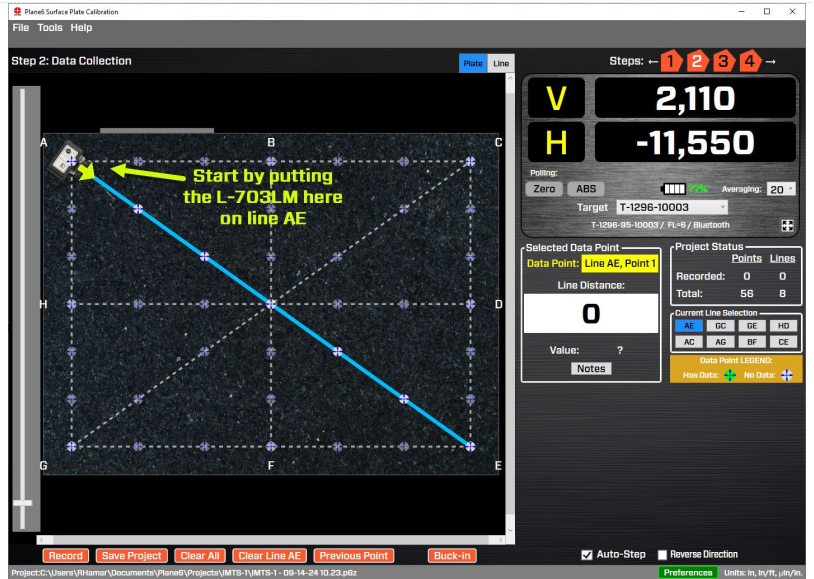
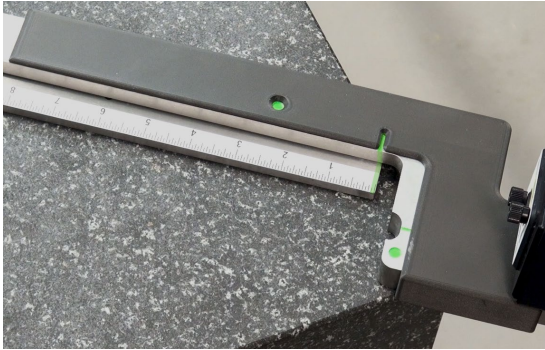

Push A-703SP-LM Laser Fixture against the straightedge where it will contact the bearings.

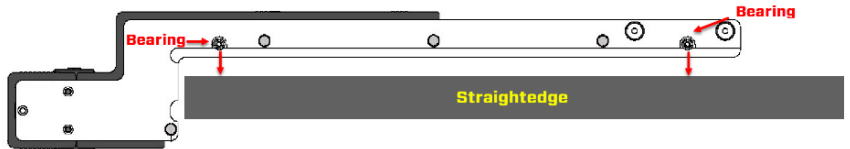

- b. Place the A-703SP-LM next to the straightedge, and, then, holding down the straight edge, slide the laser fixture against the straight edge to make contact and align the green line with the zero point on the straightedge. You can squeeze them together as you slide it along the bearings.

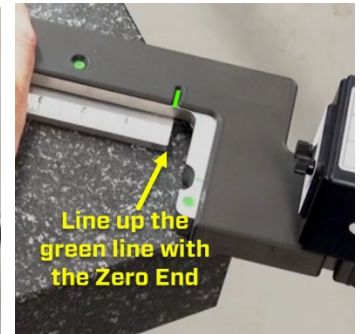
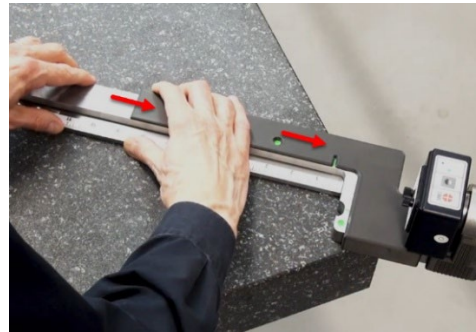

- c. Now rotate the roller bearings away from the straightedge by turning the knobs on top of the A-703SP-LM in the clockwise direction.

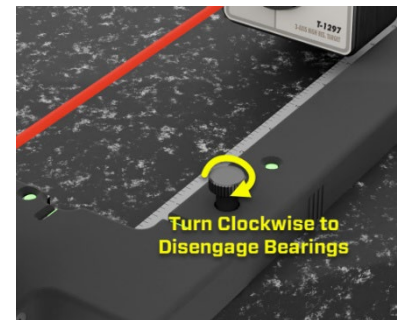

Step 5 – Assemble the T-1297 Target and A-1297-SP Measuring Base

Now assemble the T-1297 Target into the A-1297-SP Precision Measuring Base. Notice that the T-1297 has a tooling ball. This will insert into the slot on the A-1297-SP to align the target to the A-1297-SP base's measuring feet. Tighten the thumb screw very tight. Turn on the target.

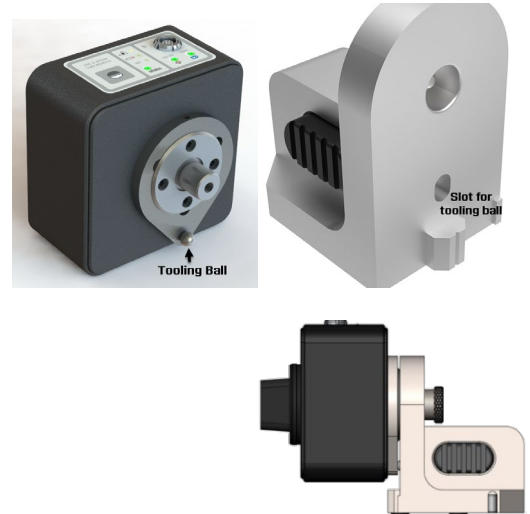

Step 5a – Place T-1297 Target & Base on the Plate

Place the T-1297 Target and Base on the plate near the laser, *gently* push it against the straight edge, and line up the *Measuring Plane* of the base with the zero point on the scale (see image). Check to make sure that the **H Axis** value is less than 30,000 μm . (760 μm), which it normally is.

Zero the display by clicking **Zero**.

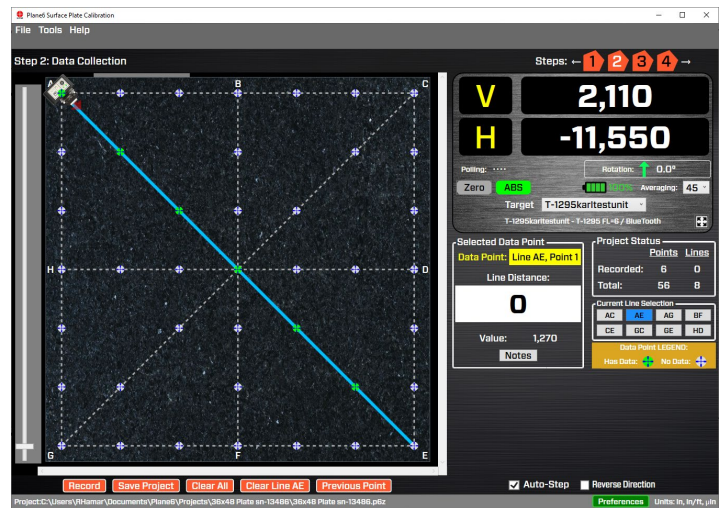

Step 5b – Move the T-1297 Target & Base to the Far End of Straight Edge

- Move the T-1297 Target+Base to the *far* end of the straight edge.
- Adjust the H (yaw) and V (pitch) axis adjustments on the L-703S laser to tilt the laser beam until the values are less than:

H Axis: $\pm 5,000$

V Axis: $\pm 2,000$



This aligns the laser beam to the straight edge and puts it on the most accurate part of the PSD sensor.

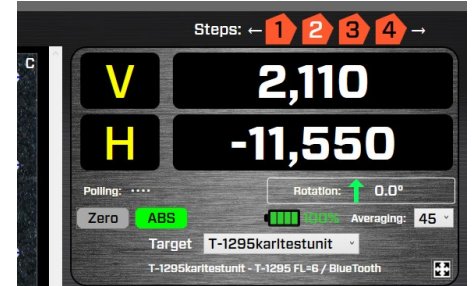
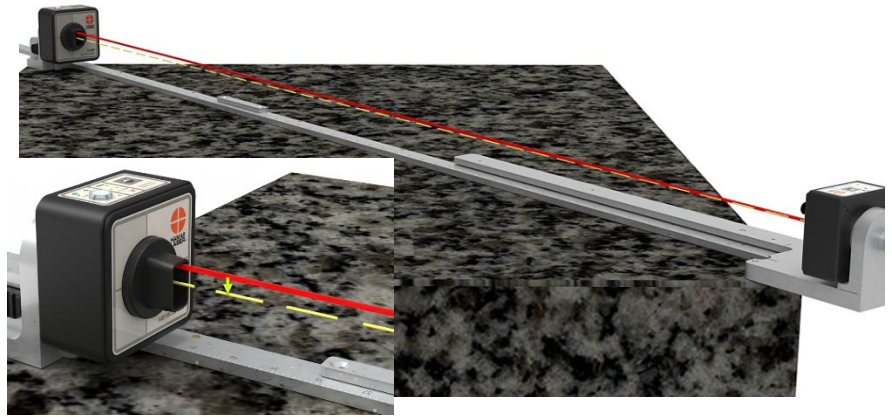

Step 5c – Move the T-1297 back to Near Position and Start Recording

Move the T-1297 Target back to the near point and click **Record** to record the first data point. When positioning the target, line up the *Measuring Plane* (front edge of target base mounting surface) with the ruler dimension before hitting **Record**. In this case, it should be on the zero (0) point on the ruler.

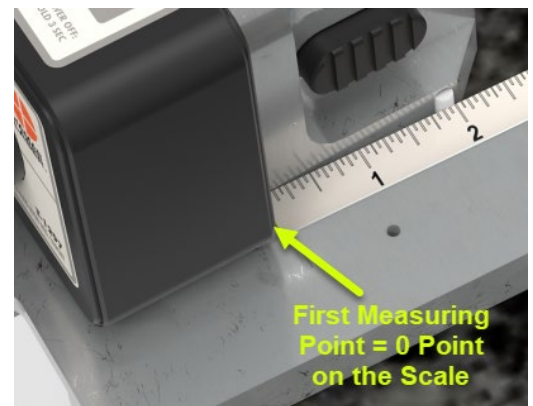
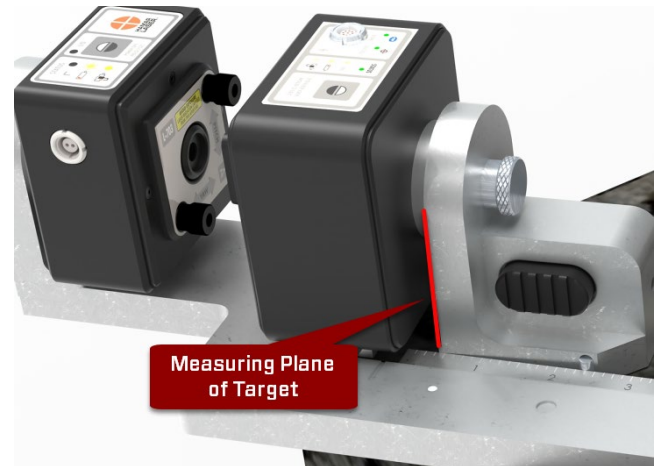

Step 6 – Move to Next Point and Continue Recording

Move to the next point by looking at the *Line Distance* display in **Plane6 Step 2** to tell you where to position the target. Click **Record**.

Continue recording until all the points are taken.

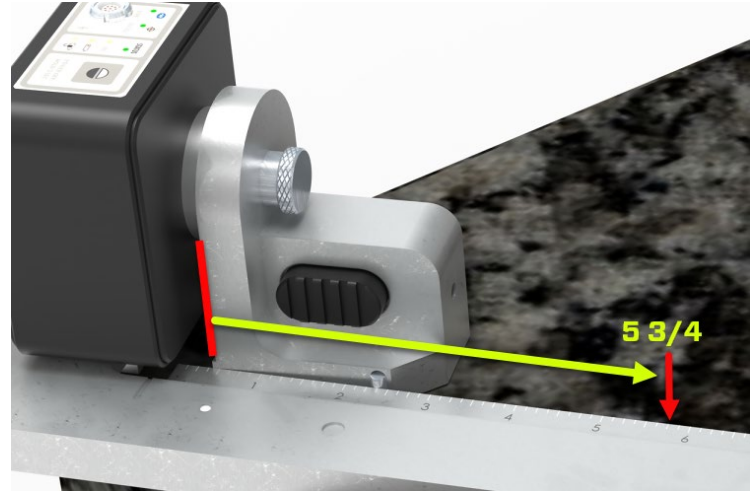
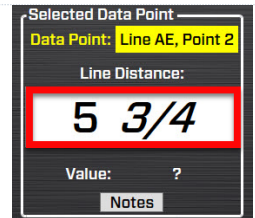
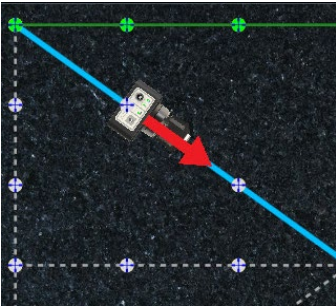

Step 6s - Notes on Moving the Straight Edge

When moving the A-703SP-LM Laser Mount and A-703SP-SE Straightedge to the next line, follow these basic steps:

- Place the straightedge on the line using the corner locating tool to position it correctly, as shown above in Step 2.
- Place the laser mount over the straight edge (see above) and slide it so it hits the straight edge at both ends. You can “pinch” them together to make contact but try to keep the straightedge from moving.
- Make sure to line up the start of the scale with the mark on the laser fixture.
- Once the laser fixture is in place, do NOT touch it when taking data. This is because even small movements of the laser fixture could cause the laser to move, especially at the far end of the line, which would require restarting the data taking for the line segment.
- You can put your hand on the straightedge to help prevent it from sliding.

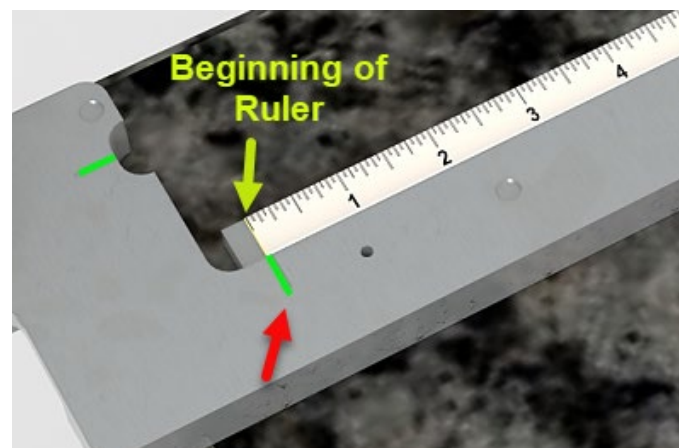
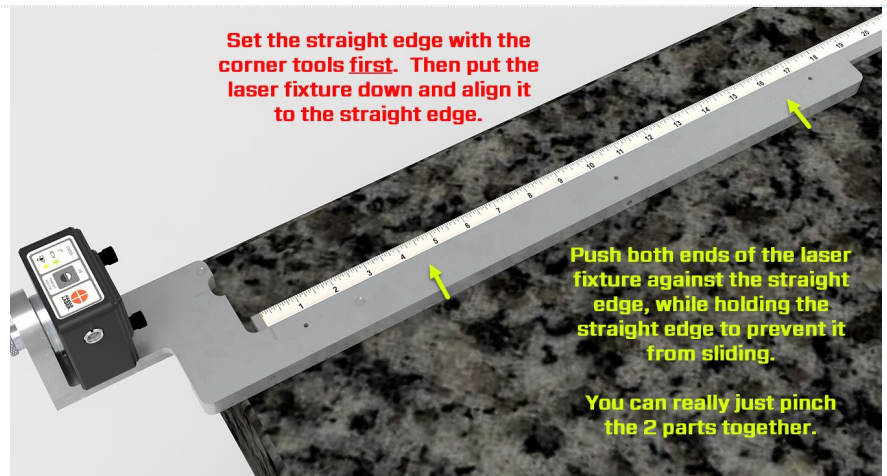



Step 7 – Move Laser to Second Diagonal and Record Data

- Plane6 automatically moves the recording line segment to the next line as shown in the *Current Line Selection* table, which is GC. *Note - the location of the target icon is where to put the laser fixture.*
- Take off the L-703SP-LM Laser Mount and set it aside.
- Set up the Corner Locating Tools on the corners for the second diagonal segment.
- Then move the straight edge to the second diagonal using the corner locator tools to position the straight edge.
- Place the L-703SP-LM Laser Mount on the straight edge, as shown Step 3a above. Place the target at the near position and you are ready to record.

Note - you do not need to re-adjust the laser beam since you are using the same straight edge, which means the alignment of the laser to the straight edge should hold its position, so after positioning it and the L-703SP-LM, you can start recording.

Project Status	
Points	Lines
Recorded: 49	7
Total: 56	8

Current Line Selection			
AE	GC	GE	HD
AC	AG	BF	CE

Data Point LEGEND:	
Has Data: 	No Data: 

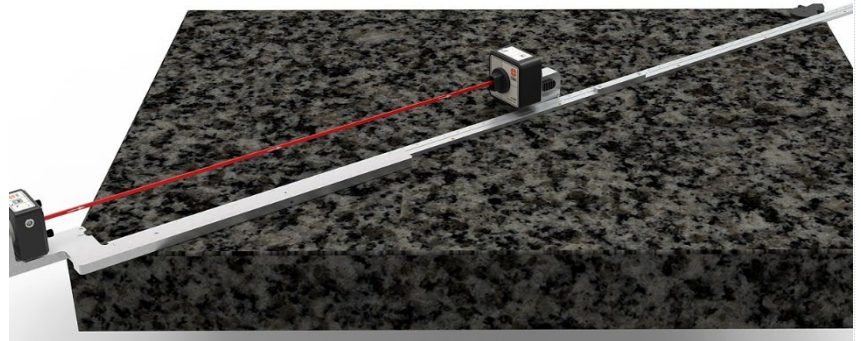
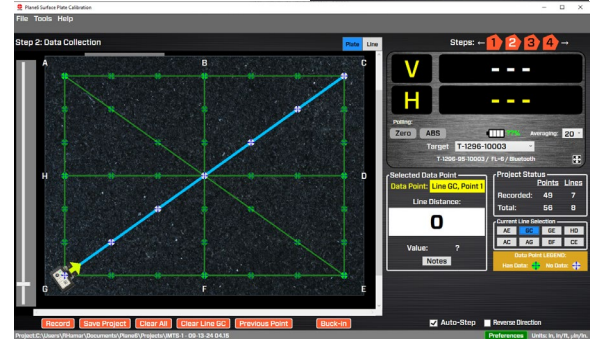

Step 8a – Move Laser and Straight Edge to Outside Edge and Record Data

Now move to the next line segment, an outside edge, as shown in the *Current Line Selection* table (see below), usually Line GE. Pay attention to which edge to record, as shown in Step 2. Also, pay attention to which end of the line to put the L-703SP-LM Laser Fixture. For line GE, it will be the right side of the line – see below.

Find the straight edge that best matches the length of that side of the plate. See Step 2 for instructions on lining up the straight edge to the corner locating tool.

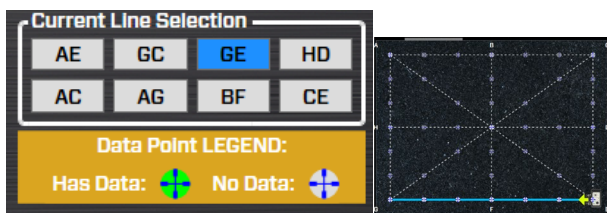
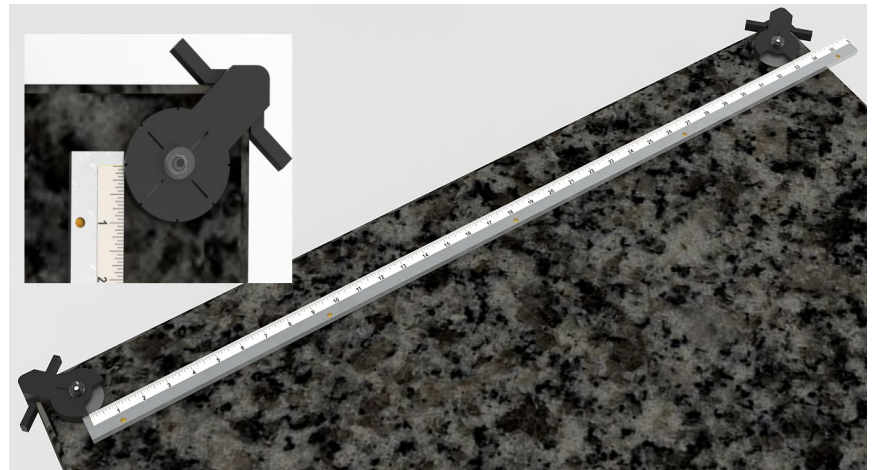

Place the L-703SP-LM Laser Mount on the straight edge as shown Step 3a above. Place the target at the near position and you are ready to record.

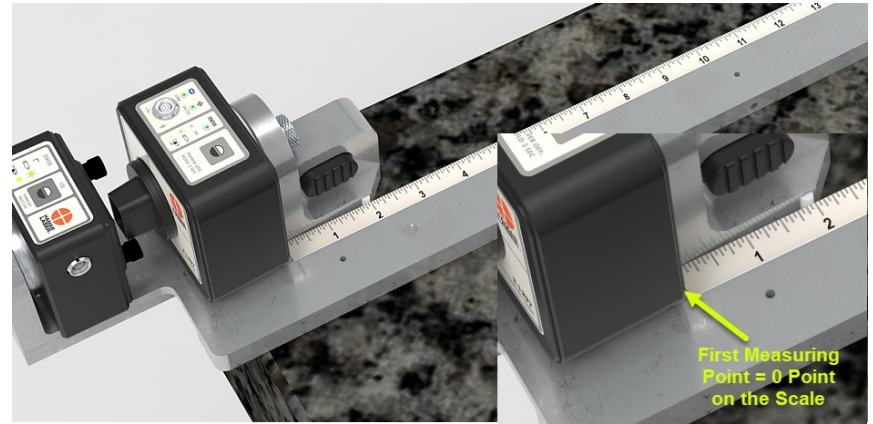
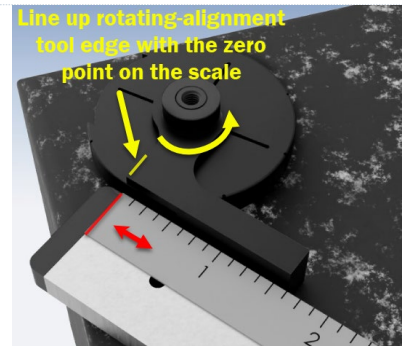

Step 8b - Record Second Outside Edge of Plate

Locate the second outside edge recommended by Plane6, usually Line HD and repeat the process in Step 7a

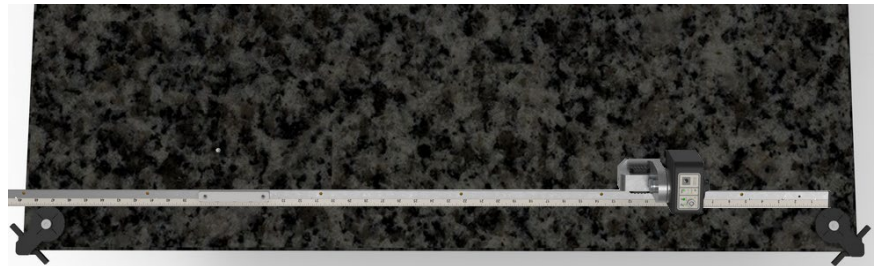

Step 9 – Record Mid-Point Line Segments

Using the mark made by the Mid-Point Marking Tool (see Step 1), position the Corner Locating Tool on the midpoint of the outside edges and align the mark on the locating tool with the mark on the plate.

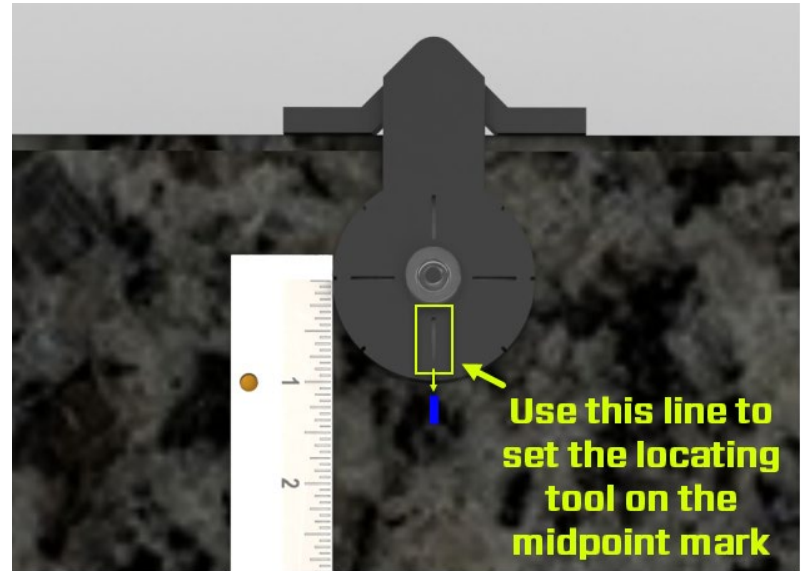

Position the straight edge with the *scale side* touching the Corner Locating Tool and position the zero point on the scale with the rotary edge on the locating tool.

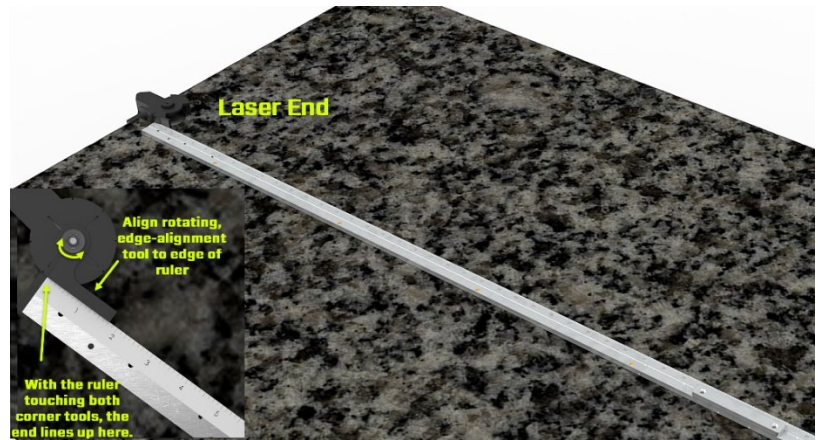

As before, place the A-703SP-LM fixture on the side recommended by Plane6 and place the target in the near position and hit Record. Continue taking data for the whole segment.

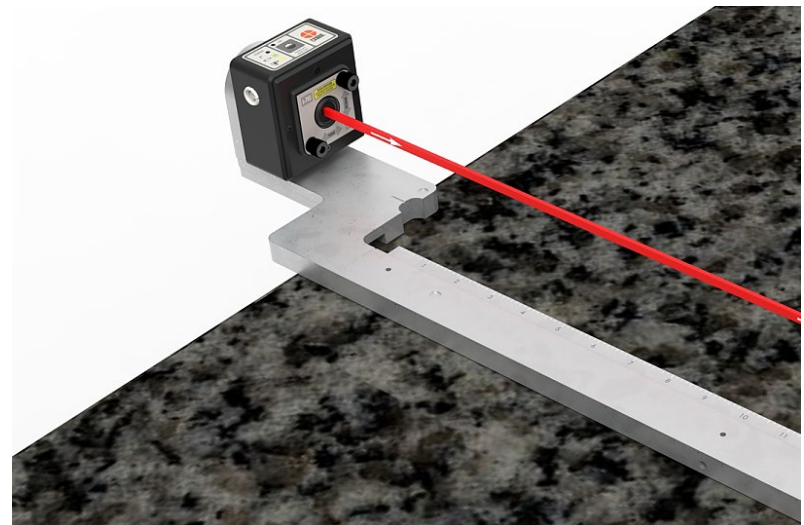



Step 10 - Record the Rest of the Line Segments

Record the rest of the line segments, following the recommended sequence from Plane6.

Project Status		
	Points	Lines
Recorded:	96	8
Total:	96	8

Current Line Selection			
AC	AE	AG	BF
CE	GC	GE	HD

Data Point LEGEND:

Has Data:  No Data: 

Notes on taking data:

1. **Display Value Tolerance** - Pay attention to the H axis value. If the value gets higher than 10,000 $\mu\text{in.}$ (255 μm), then the Plane6 data display will turn orange, indicating that this is too far off center in the horizontal axis. This may mean the laser fixture moved. Check to make sure the laser fixture is still against the straight edge. If not, then move them together again.

Move the target to the end of the straight edge and see if the orange color disappears. If so, this means it's back in spec. Then hit **Clear Line XX** to restart the data taking for the line segment.

If it's still orange, you can simply adjust the H axis until it's less than 25,000. Then hit **Clear Line XX** and retake the data for that line.

2. **Checking Recorded Data Points** - You can always check data values for a given point by hovering over it and seeing the values or by clicking on it and seeing the values in the table.
3. **Retaking a Data Point** - You can also click on a point and retake the data point if you think it is wrong.
4. **Manually Picking Data Points** - You can turn off *Auto Step* if you want to move the target icon manually. First click on the line segment you want and then click on the point you want to record. The target icon should be over the point indicating it's ready to take data.
5. **Reversing Direction on a Line Segment** - You can also hit *Reverse Direction* to change the direction of a line if you need to.

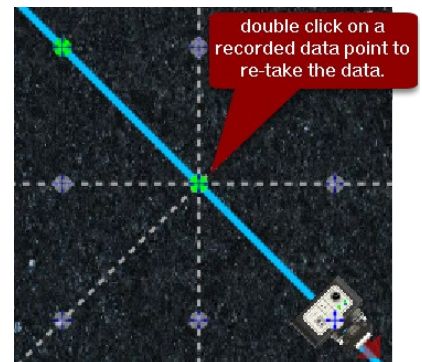
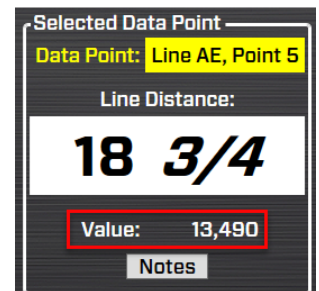
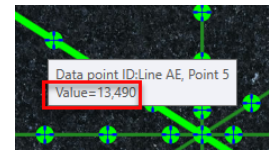
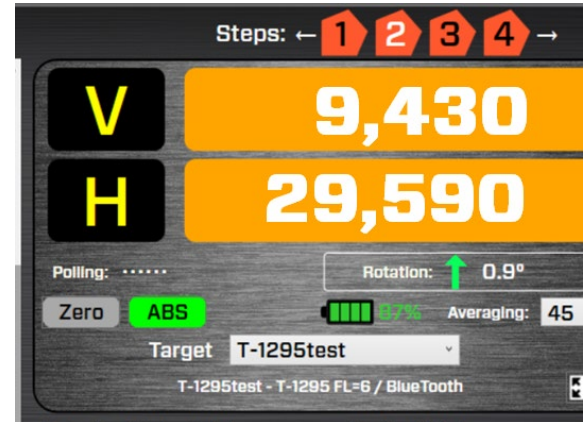

Step 9 – Review Results in Step 3 Results

Now click on Step 3 to view the results. The plate grade is shown, the tolerance for that grade and the overall flatness results from the data. A green check mark or red X tells whether it's in or out of tolerance.

There is also an additional check for the center point elevation difference, as is directed in the B89 Standard. The tolerance is also displayed. According to the standard, if the center check is out of tolerance, it is recommended that the data be re-recorded. You may be able to retake one of the 2 center line segments to get it in tolerance. See the manual for a procedure to retake the line data.

Plane 6 also displays the data tables for each line segment. This is all displayed in the report.

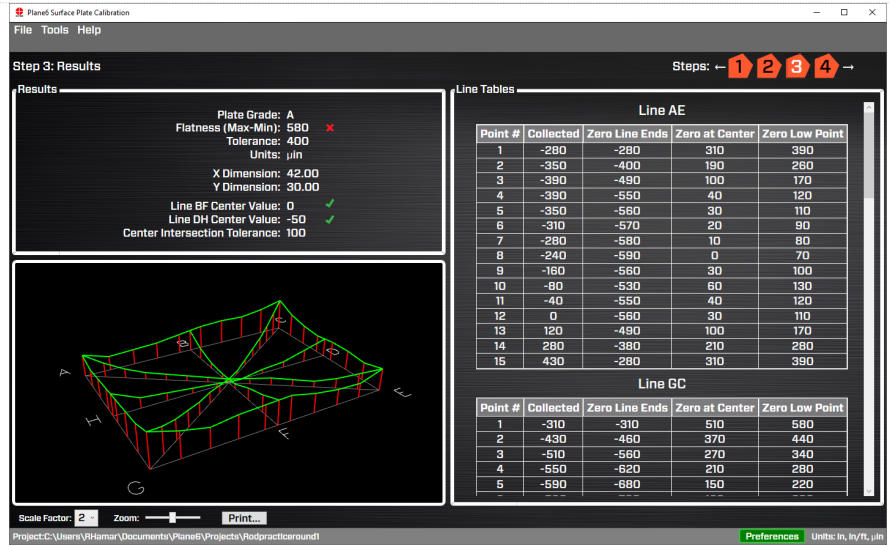

Step 10 – Review Graphical Results in Step 4 3D Graph

You can go to Step 4 3D Graph to look at an adjustable 3d graph of the results. You can zoom in/out and rotate the view to see the results. You can also magnify the elevation change to better show the results.

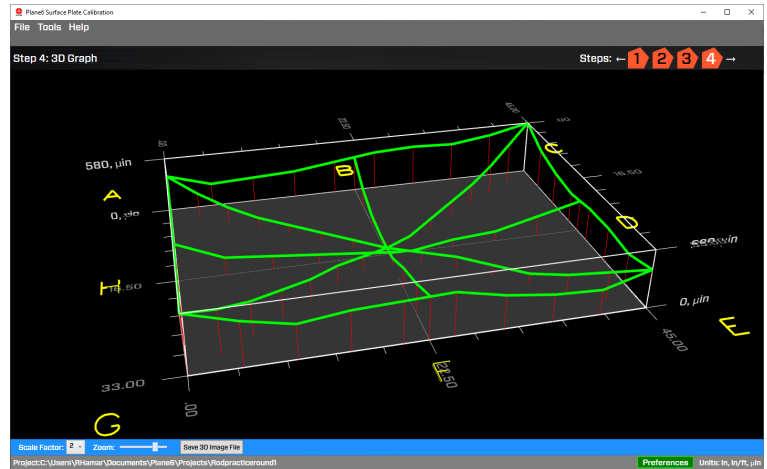

Plane6 Sample Report



Plane6
Repeat_3 Results

Plate Grade: B
Flatness (Max-Min): 440 X
Tolerance: 200
Units: μ m

X Dimension: 39.13
Y Dimension: 27.13

Line BF Center Value: -10 ✓
Line DH Center Value: -10 ✓
Center Intersection Tolerance: 100

Plate Serial Number: 7490-89R
Technician Name:
Contact Info:
Recording Date:
Recording Time:
Temperature (Top): 72.4
Temperature (Bottom): 74.8
Project Notes:

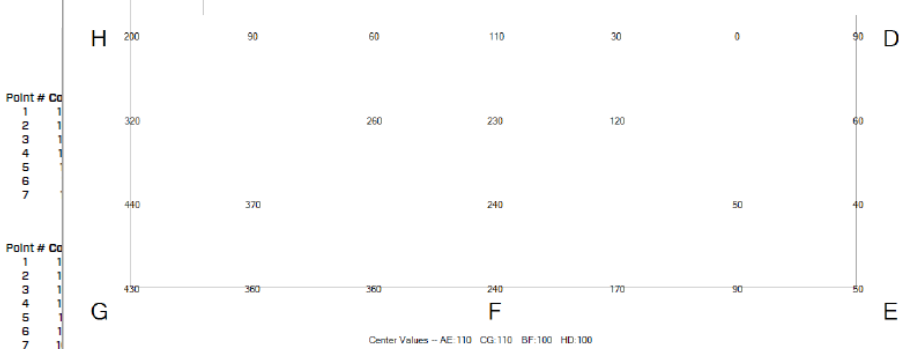
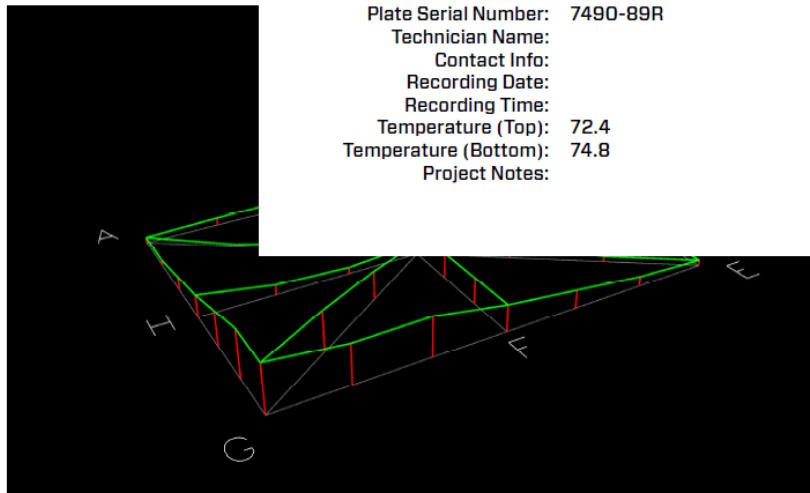

Point # Co

1	1
2	1
3	1
4	1
5	1
6	1
7	1

Point # Co

1	1
2	1
3	1
4	1
5	1
6	1
7	1

1	10,750	90	200	4	10,750	-30	90
2	10,830	-20	90	5	10,870	-50	60
3	10,590	-50	60	6	10,980	-70	40
4	10,630	-10	100	7	11,140	-60	50
5	10,550	-80	30				
6	10,510	-110	0				
7	10,590	-30	90				

Line HD

Point #	Collected	Ends to Outer Center	Zero Low Point
1	10,750	90	200
2	10,830	-20	90
3	10,590	-50	60
4	10,630	-10	100
5	10,550	-80	30
6	10,510	-110	0
7	10,590	-30	90

Line BF

Point #	Zero Line Ends	Ends to Outer Center	Zero Low Point
1	10,710	50	160
2	10,630	-60	50
3	10,670	-50	60
4	10,750	-10	100
5	10,910	120	230
6	10,940	120	240
7	10,980	130	240