

L-703B Bore Alignment Laser System

Aligning Crank-Case Bores and Bearing Journals is Now Faster and Easier Than Ever



L-703B Bore Alignment Laser System



The Leader in Laser Bore Alignment Technology

Hamar Laser has been making bore alignment lasers for nearly 50 years. In fact, we designed the very first bore alignment laser for Westinghouse back in 1973! We know bore alignment.

Patented Self-Centering Bore Adapters

Our patented, self-centering bore alignment targets are the easiest and fastest way to check bore alignment because they do not require a bore “sweep” or a reversal procedure to eliminate bore measurement problems due to diameter changes. To get a measurement, simply insert the bore target and self-centering adapter into the bore, and within 5 seconds you have a measurement of its concentricity to the end bores. The real-time alignment results are displayed on a simple 2-axis readout. In most cases, you can achieve accuracies down to .0002 in. (0.005 mm) in 10 feet (3 m).

Bore applications include:

- Engine Blocks
- Compressor Bores
- Shaft Bearing Bores
- Stern Tubes
- Plus many more

Bore Alignment Results within 15-20 Minutes

With the L-703B, alignment of bores is fast and easy: Setup takes 10 to 15 minutes and taking a bore concentricity measurement with our A-512 Self-Centering target takes just 5 seconds. Overall a 10-bore engine block takes less than 5 minutes to measure! That’s up to 3x faster than with optical bore scopes or tight wire!

Self-Centering Target Adapters Reduces

Measurement Points by 50%

With typical bore alignment lasers, you either need to sweep the bore to center an alignment fixture or take the measurement twice, once with the target mounted normally and once with it inverted, to take into account diameter changes and centering errors. With our self-centering bore adapters, you only need to take the measurement once because diameter changes do not affect the alignment. This results in 50% fewer measurements and a very fast alignment check!

More Accurate and Repeatable Measurements Than Optics

With optics, the measurement process can be more of an “art” than a science, since one operator will “see” a different set of values than another. The L-703B System uses high-resolution electronic sensors to detect the laser beam position, offering greater accuracy and repeatability. The system offer a resolution of .00004 in. (0.001 mm) and bore measurements are repeatable to .0002 in. (0.005 mm).

Extend Component Life, Reduce Downtime

Misaligned bearing bores will cause premature failures, requiring frequent replacement, more downtime, and higher maintenance costs. Proper and more accurate alignment helps components to last longer and prevent big problems — before they occur.

Key Features:

- 15-minute setup time. Measure each bore in seconds.
- Self-centering adapters are easy to insert into tight spaces and require no sweeping
- For diameters from 2.25 in. (57.2 mm) to 40 in. + (1 m)
- Optional Small-Bore Targets can align bores as small as .70 in. (17.5 mm)
- Adjustable legs fit a large range of bore diameters
- Leg-Setting Gage centers adapters to .0002 in. (0.005 mm)
- Readouts update in real time as the bore is adjusted
- Two laser mounting orientations: a) horizontal surface or b) bore flanges
- Optional Bore9 software aids with setup, records bore data and analyzes the results
- Operational Range of 50 ft. (15 m)
- Durable and rugged design



The L-703B can be mounted on the face of a bore or on an instrument stand to easily handle any bore application.

Features Designed With Versatility in Mind

Self-Centering Adapters — The Key to Speed

The A-512 Target and A-514 Adapter Hubs are designed so that the PSD (position sensing detector) is centered axially between the adapter's 4 feet, two of which are offset axially from the other two feet. This puts the PSD on the pivot point of the adapter and allows the target's angle of incidence to the laser to vary by up to 45° without changing the adapter's centering. To insert the target/adapter into the bore, a weighted handle is attached to the target/adapter and the adapter is tipped forward, which allows it to be inserted into the bore. The

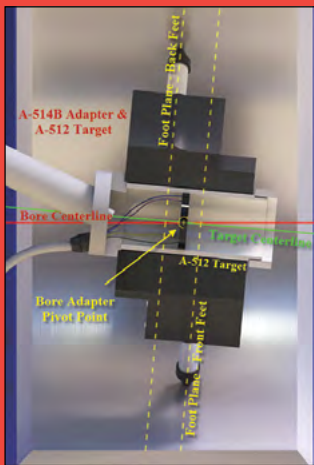

weight of the handle forces the target to tip backward and seat the target legs into the bore, centering the adapter/target.



A-514GS Measuring Leg-Setting Gage

4-Axis Laser Adjustment Fixture

The L-112 Laser Stand provides 4-axis adjustment capability to quickly align the laser beam to any 2 reference bores for fast alignment checks. The fixture can be mounted either on the face of a bore or on a horizontal surface or instrument stand.



Adjustable Bore Adapter

Our A-514 Self-Centering Target Adapters have adjustable measuring legs that allow adapters to be used for diameters ranging from 3.75 in. (95 mm) to 40 in. (1 m) - see specifications for details.



Bore9 Software showing plot of bore concentricity.

Coarse/Fine Angular Adjustment

Precision angular adjustments provide angular pointing control of the laser beam so it can be tilted with a resolution of .00002 in./ft. (0.0016 mm). Coarse angular adjustments offer an adjustment range of +/- 2.5°.

Customized Bore Adapters Reduce Price

For those applications that only have a few bore diameters to measure, we offer our A-512LTA Bore Adapter, which uses a customized set of measuring legs for each bore diameter, so you don't have to pay for a large range of bore diameters that you won't ever use.

Small-Bore Measurements

For small-bore applications, we offer our A-220 and A-221 Self-Centering Bore Targets with customized bore adapters that can measure bore concentricity down to .70 in. (18 mm) diameters.

Large-Range Targets

For long-distance application that require a large measuring range, our T-1218 2-Axis Target offers a 20x20 mm PSD. It has a hardened, stainless steel body with a 3 in. (76.2 mm) diameter mounting surface. Use with the T-1225L Bore Adapter to measure bores from 5.75 to 40 in. (146 -1,100 mm).

Optional Bore9 Alignment Software

Data can be collected and displayed in real time with our Bore9 Software for Windows 7/8/10 tablets and laptops. Bore9 plots bore misalignment: 1) relative to end bores, 2) relative to two user-defined bores or 3) relative to Best Fit line.

How It Works - L-703B Measuring Bore Concentricity on an Engine Block

Setup Laser, Enter Dimensions, Measure Bore Alignment and Generate Report in 30 Minutes or Less! Here is how:

1. The number of bores, dimensions between bores and tolerances are entered into Bore9.



Bore9 Software - Step 1 Setup Screen

2. The L-703B Laser is mounted externally either on an instrument stand or on the flange of the reference bore using the L-112 Laser Stand.

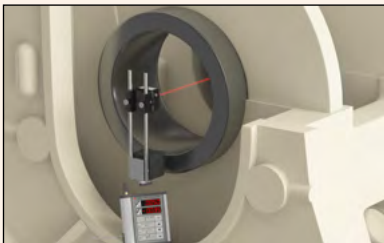

L-703B/L-112 Laser and Stand Mounted on Bore Flange

3. Next, the A-514 Adapter legs are set to the nominal bore ID using the A-514GS Leg-Setting Gage.

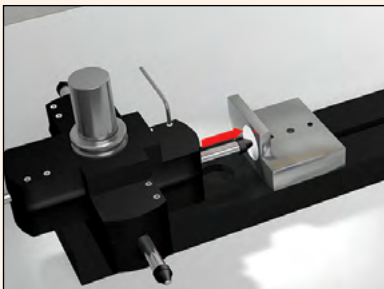

A-514GS Leg-Setting Gage

4. Then the A-512 Target is inserted into the A-514 adapter and the R-1307B-2.4ZB Readout is connected.

5. The A-512/A-514 are then inserted into the end bore closest to the laser.

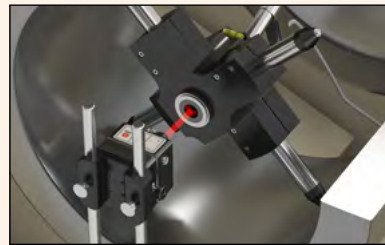

L-703B Laser/L-112 with A-512/A-514 Target and Self-Centering Adapter

6. The laser beam needs to be centered to the bore, so the centering adjustments in the L-103 Optical Beam Translator are used to center the laser beam to the A-512 target.



Centering Adjustments on L-103 Beam Translator and L-112 Laser Stand

7. Setup dimensions are entered into Bore9 to speed up the setup.



Bore9 Step 3 Buckin Dimensions

Continued on next page.



How It Works - L-703B Measuring Bore Concentricity on an Engine Block

8. Now the A-512/A-514 are moved to the far reference bore and the H & V values are recorded in Bore9.

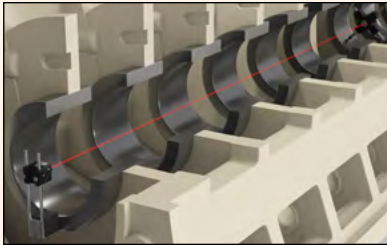

9. Bore9 calculates a Set Point and the L-703B's angular adjustment are used to steer the laser to the Set Point.



L-703B Laser's Pitch & Yaw Angular Adjustments



Bore9 Step 3: Buck-In with Set Points Calculated

10. The A-512/A-514 are returned to the near bore, where the values should equal the Set Point, which means the laser is bucked-in (aligned) to the end bores. The L-703B is now ready to record data in Bore9 Software.

11. To take data, the target & adapter are then moved to the first inner bore and the alignment value is recorded. This is repeated for each bore. It takes just 5 seconds to take a data point.

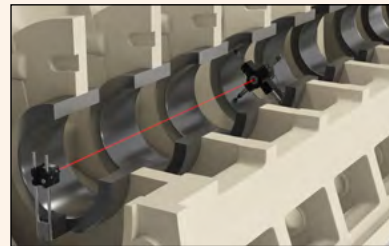

A-512/A-514 Moved to Inner Bore

12. The alignment data is updates in real time, so if the bore is out of alignment, it can be adjusted to zero while watching the values update on the R-1307 readout or Bore9 software.
13. The data is analyzed by Bore9 and the results are shown in several different formats and a printed report generated. inserted into the end bore closest to the laser.



Bore9 Step 5: Results Concentricity Plot

Other Applications for the L-703B Bore Alignment Laser

Applications Overview

Hamar Laser bore systems can handle a wide range of bore alignment and straightness determination and measurement tasks. Even extremely difficult bore alignment challenges, like spherical bearings, can be done easily. If you do not see your application listed, please contact us to discuss your requirements. We will be more than happy to provide a solution that's right for your unique alignment problem.

Automotive & Locomotive Engine Blocks

- Crankshaft and camshaft line bores

Manufacturing & Metalworking

- Boring-bar bearing alignment
- Compressor bores
- Cylinder straightness
- Gun barrel straightness
- Lathe/turning center spindle alignments
- Workpiece bore-to-spindle alignment

Marine

- Diesel engine blocks
- Propeller shaft bearing bores
- Stern tube alignment

Plastics

- Twin-barrel extruder alignment
- Twin-barrel extruder straightness and wear

In-Situ Bore Machining QC Checks

Our other bore laser, the L-703B, is used with our T-218 Target, both of which have 2.2495 in. mounting OD's that fit right into a standard boring-bar bearings to do a post-machining QC straightness or concentricity check.

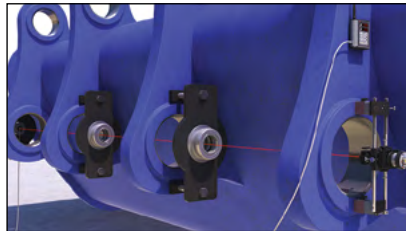

L-703B Aligning Boring-Bar Bearings in Bucket Loader

Stern Tube & Propeller Shaft Bearings

The L-703B can quickly and easily check stern tube and propeller shaft bearing alignment. It can either be mounted on the gearbox shaft with a fixture and aligned to the rotation axis, or mounted at the aft strut bore and aligned to the stern tube bores. This saves lots of time versus a tight wire with much higher accuracy.

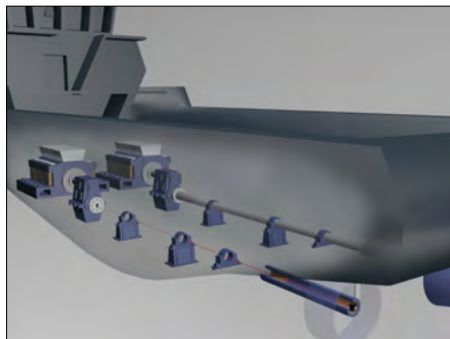

Twin-Barrel Extruder Alignment

Using our A-703A Spline Fixture, our L-703B can be setup on a twin-barrel extruder in about 10 minutes and aligned in less than 1 hour. The adapters can also be used to measure barrel wear.



Compressor Bores 2x Faster and More Accurate

The L-703B can also be used on compressor bores to check concentricity up to 2x faster and with 3x higher accuracy than tight wire. Even the largest compressor bores can easily be handled by the L-703B. We even have a target that works on "cut away" bores in reciprocating compressors!

Bore Straightness on Large-Bore Gun Barrels and Hydraulic Cylinders

Checking the bore straightness of a long cylinder is a simple procedure. After setting up the laser, a special, self-centering target with roller-bearing measuring feet is inserted into the bore using an insertion pole and the readings are recorded at predetermined increments. Cylinders and barrels up to 33+ feet (10+ m) can easily be measured for straightness.

L-703B Laser Borescope Alignment System

Specifications

L-703B Bore Alignment Laser

Size	(See line drawings)
Weight	15.9 oz. (0.45 kilograms)
Battery	3.6v LiPo rechargeable
Battery Life	11+ hours continuous use
Concentricity	Laser beam concentric to mounting stud to within .0005 in. (0.013 mm) - no adjustment
Angular Adj. Resolution	.00002 in/ft (0.0016 mm/m)
Angular Adj. Range	±0.39° (±0.08 in/ft or ± 6.6 mm/m)
Operating Distance	up to 50 ft. (15 m) when used with A-510/A-512 Targets
Laser Type	Laser < 0.9 mW, BRH Class II
Laser Wavelength	650 nanometers
Materials	Plastic housing, aluminum frame and 440 SS steel mounting stud with hardness of RC 54-60.
Laser Beam Modes	Continuous and single-blink mode (for ambient light correction). Supports 2-axis bore cabled targets when used with R-1307, such as the A-220, A-221, A-510, A-512, T-212 and T-271

L-112 Laser Stand

Angular Adj. Range	±3.0° (±.61 in/ft or ±51.0 mm/m) - vertical (pitch) only. (Note: rotate the mag base for coarse horizontal angular adjustment)
Angular Resolution	.0006 in/ft (0.05 mm/m) - vertical (pitch) only
Translation Range - Horizontal	±.20 in. (± 5.1 mm) using the horizontal translation stage
Translation Resolution - Horizontal	.0001 in. (0.0025 mm) (Note - L-103 has .000025 in. translation resolution)
Translation Range - Vertical	±4.27 in. (108 mm) by sliding L-112 up/down the posts
Translation Resolution - Vertical	.010 in. (0.25 mm) by sliding L-112 up/down the standard 12 in. (304 mm) posts (Note - L-103 Optical Beam Translator has .000025 in. resolution)

L-703B Bore Alignment Laser

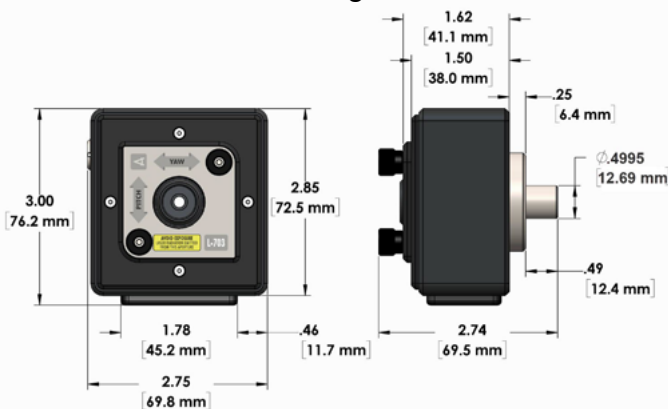

A-512 2-Axis Bore Target

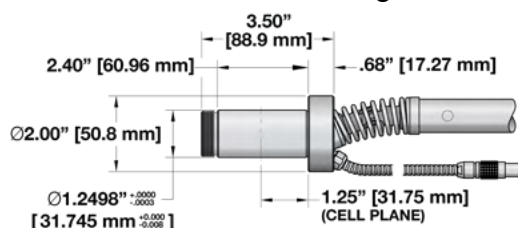

L-103 Optical Beam Translator

X-Y Center Adj/Resolution	.0001 in. (0.0025 mm)
X-Y Center Adj. Range	±.043 in. (±1.09 mm)

A-512 Bore Target

Sensor	2-axis 10x10 mm PSD
Resolution	.00004 in. (0.001 mm) with R-1307 Readout and Bore9 Software
Measurement Error	<2%
Concentricity	PSD concentric to OD to within .0003 in. (0.008 mm)
Mounting Surface OD	1.2498 in. (31.745 mm)
Material	Mounting surface 303 SS

A-514 Bore Target and Adapters

A-514 Adjustable Self-Centering Bore Adapters	For bore diameters from 3.75 to 6.75 in. (95 to 172 mm).
A-514A-EX Small-Bore Target Adapter	For bore diameters from 3.75 to 9.75 in. (95 mm to 248 mm).
A-514B Medium-Bore Target Adapter	For bore diameters from 6.50 to 17.50 in. (165 to 445 mm).
A-514B-EX Medium-Bore Target Adapter	For bore diameters from 6.50 to 25.75 in. (165 to 655 mm).
A-514C Large-Bore Target Adapter	For bore diameters from 17.00 to 40.00 in. (431.8 to 1,000 mm).
A-514G Bore Gage	Sets A-514 Adapters legs to correct bore diameter to .0002 in. (0.005 mm). Use A-514GS for A-514A & B Adapters. Use A-514GL for A-514A, A-EX, B, B-EX & C Adapters.

A-514A Target Adapter

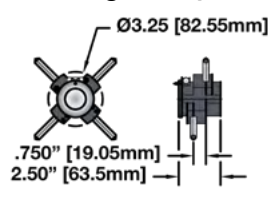

A-514B Target Adapter

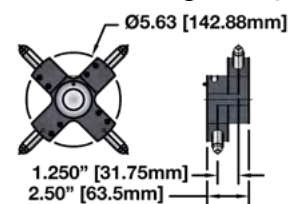

A-514C Target Adapter

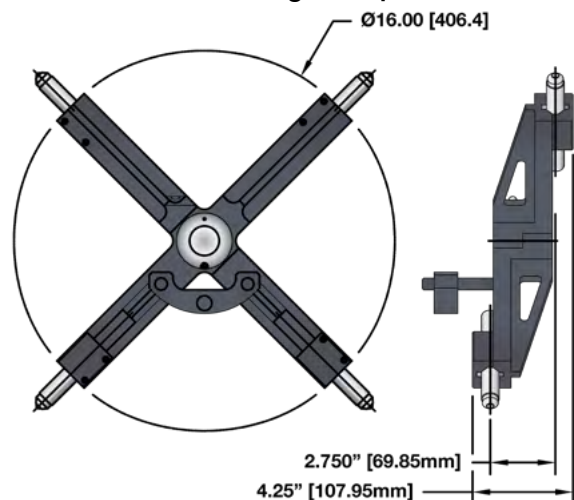

Hamar Laser Instruments, Inc.
5 Ye Olde Road Danbury, CT 06810
Fax: 203.730.4611 Int'l: +1.203.730.4600
sales@hamarlaser.com www.hamarlaser.com



U.S. and foreign patented and/or patents pending. Made in the USA.

© 2022 Hamar Laser Instruments, Inc (7/22)