

L-742 Ultra-Precision Dual-Scan[®] Roll Alignment System

Aligning Parallelism
of Rolls Has Never
Been Faster

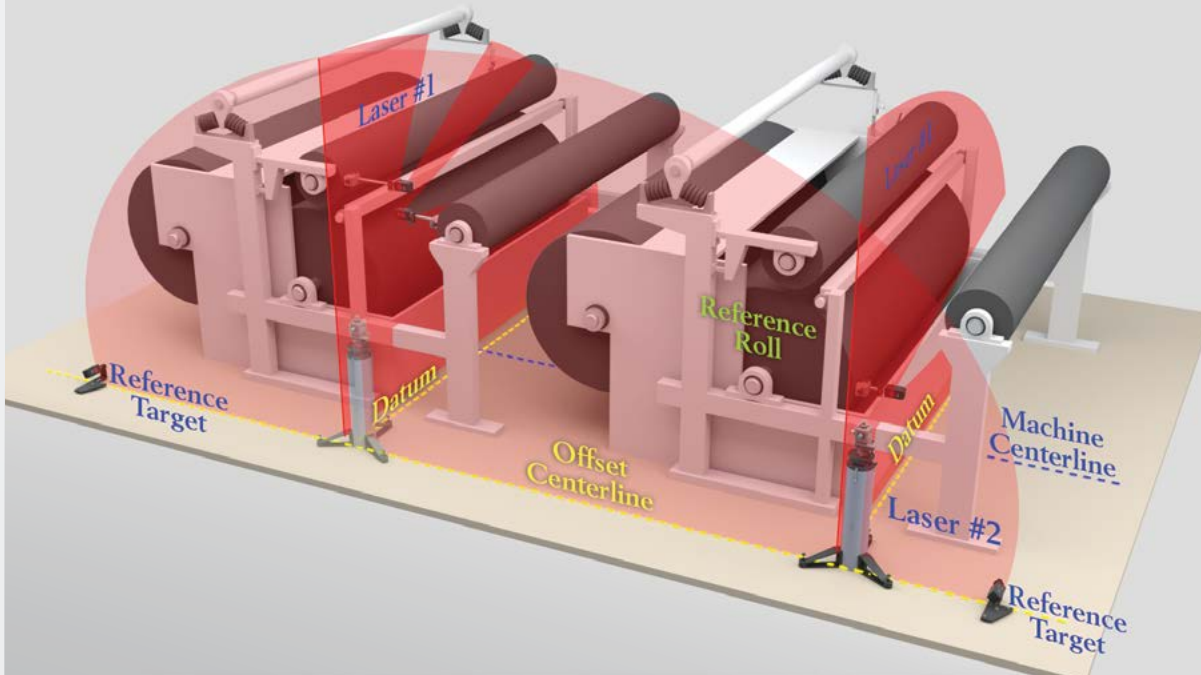

Why the L-742 Roll Alignment System is Better



- Roll parallelism accuracy of .000045 in/ft (0.0038 mm/m)
- Up to 70% faster than competitive systems
- Auto rotating laser planes
- 200' (30.5 m) measuring range
- Longer range, fewer setups
- Multiple wireless targets reduces manpower
- Very easy to use with minimal training requirements
- Real-time data displays for measuring and aligning

Today's alignment lasers are better, faster and more accurate than any other method for aligning rolls and there is no better laser than our L-742 Ultra-Precision Dual-Scan® Roll Alignment System. The system is so easy to use and accurate that you can get the alignment done right the first time, saving significant costs in reduced downtime, scrapped product and quality problems.

L-742 Up to 3X More Accurate than Optics

With a target electronic resolution of .00002" (0.0005 mm), Hamar Laser's L-742 Roll Alignment System is accurate to +/- .002" (0.06 mm) in 200' (61 meters) under good atmospheric conditions, and that's an honest +/- .002" that everyone can see, not what some optics tech says he "sees" in his scope. The L-742 alignment results are very repeatable from one operator to the next.

2X Faster and 10X More Accurate than Other Laser Systems

Continuously rotating laser planes with multiple wireless targets means the L-742 is 2

times faster than competitive lasers that use manually rotated lasers and penta-prisms to "bend" the beam. The parallelism accuracy is .000045 in/ft (0.0038 mm/m), which is 10 times more accurate than competitive systems that have up to .0005 in/ft. (0.040 mm/m) parallelism error in their laser optics!

Multiple Wireless Targets Speeds Alignments up to 70%

The L-742 utilizes up to 5 A-1519-2.4XBE targets, with up to 150 feet (45 m) of range, to send their data to our R-1358-2.4XBE IP67 Rugged PDA Readout. The R-1358 can display up to 5 targets simultaneously, reducing alignment times by up to 70% over optics or other alignment systems.

Minimal Training, Less Manpower

The L-742 is very similar to using optics but is much easier, so the required training is a lot less. And since the measuring is done at the target, the L-742 reduces alignment manpower because a second operator is not needed to look through the optical scope. Our R-1358 Wireless PDA Readout

simultaneously displays both reference targets and the measuring target, allowing the user to quickly set up to the offset centerline reference benchmarks.

100-Foot Vertical Range Reduces Setups

The L-742 offers 2 automatically rotating laser planes with range of 100-foot (30.5 m) in radius, vertically and horizontally, which means rolls 100 feet (30.5 m) in the air can be measured without having to move the laser vertically. Few setups, faster alignments!

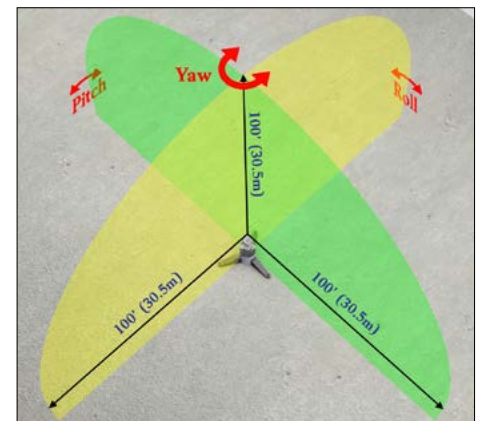

Innovative Features Designed for Fast, High-Accuracy Roll Alignments

Measure More Rolls With Each Setup

By using a laser plane, the L-742 has the ability to measure multiple rolls from the same setup. Rolls up to 100 feet (30.5 m) above the laser can easily be measured!

R-1358-2.4XB Multi-Target Display Speeds up Laser Transfer

The setup process is easy and fast because our Read16 Android PDA Display program displays up to 5 wireless targets simultaneously, so when using the Laser Transfer Method, you simply look at the data for the 2 reference targets (usually #2 & #3) and adjust the laser until both numbers are the same. Then use the measuring target to measure the roll or rolls.



R-1358-2.4XB PDA Readout with laser aligned to reference targets, showing a roll measurement

Flexibility to Use Reference Roll or Benchmarks

Normally, we recommend using a reference roll as the laser datum reference since cracks in the floor can seriously affect the position of the optical benchmarks and often result in poor alignments. However, the L-742 also offers the flexibility to use the T-1500 Floor Fixtures to pick up the benchmarks if required.

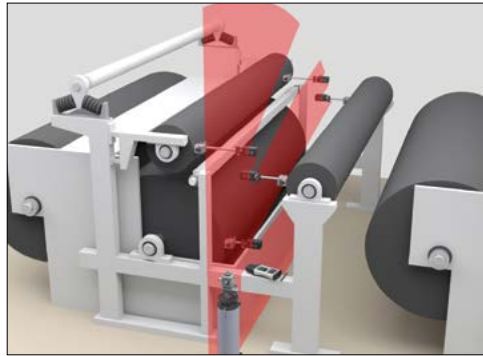

L-742 Measuring Multiple Rolls from 1 Setup

Tram Bar Measurement Method

For situations where it's impossible to put the target on the side of the roll, we use the Tram Bar Method. Here you put a tram bar over the end of the shaft and put a target on it. Zero at 12:00 and measure at 6:00 to check roll levelness. Then zero at 3:00 and measure 9:00 to get the parallelism relative to the reference roll.

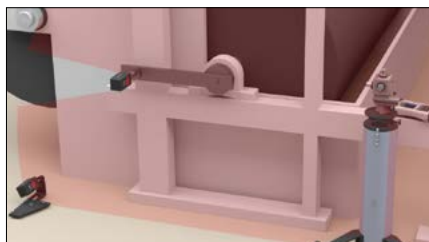
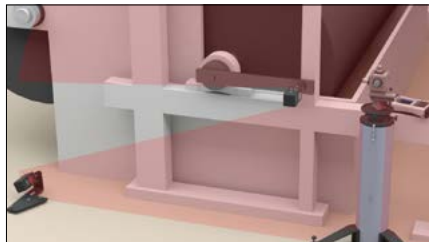

A-1519-2.4XB Target using Tramming Method to measure the parallelism



A-1519-2.4XB Reference Target Mounted on T-1500 Floor Fixture

L-742 System Features

- Two continuously rotating laser planes with operational range of 100' (30.5 m) in radius
- Laser planes flat to .00003"/ft (0.0025 mm/m)
- Using a reference roll, the measuring laser plane is parallel to roll datum to .000045 in/ft (0.0038 mm/m) at any location along the machine
- Split-Prism levels accurate to .00006 in/ft (0.005 mm/m)
- A-1519-2.4XB Single-Axis Wireless Target with 1.3" (33 mm) PSD and .00002" (0.0005 mm) resolution
- R-1358-2.4XB Wireless PDA displays up to 5 targets simultaneously
- Factory-built benchmark reference fixtures for easy laser transfers and referencing floor benchmarks
- L-106 X-Y Tripod Translation Slide to speed up laser transfers and target setup
- Typical setup time 15 minutes or less

Upgrade to L-743 Triple Scan® to Add Leveling

Add a third laser plane to the L-742, you get the L-743 Triple Scan® laser, which can add flatness, leveling, straightness and squareness to the roll alignment capabilities of the L-742.

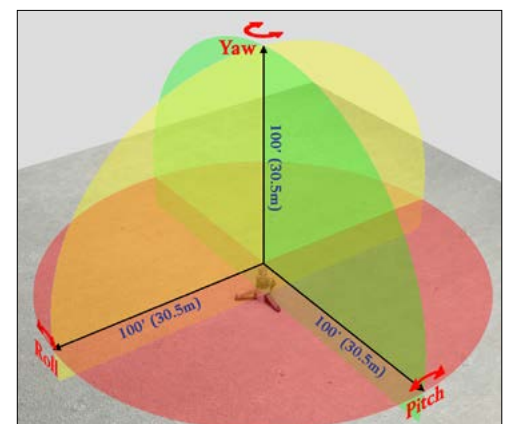

HLI vs. the Competition

Item	HLI L-742	European Systems	Optical Theodolites	Gyroscope System*
Measurement Technology	Dual Scan® Orthogonal Auto-Rotating Planes	Manually Rotating Planes + Penta-Prism Optical Square	Optical Telescope + Optical Scale	High-Accuracy Gyroscopes
Speed of Measurement	60-70% faster	30-35% faster	0% faster	60-70% faster
Ease of Use	Simple, easy setups	Complicated, long setups	Complicated, long setups	Easy to use but complicated software
Auto Rotating Laser Planes	Yes, 2	No, manual rotation	n/a	No
Live Update for Aligning Rolls	Yes	Yes	Yes	No. Report only! <i>Must use another alignment tool to align.</i>
Laser Plane Flatness & Squareness	Flatness: .00003 in/ft (0.0025 mm/m) Squareness: .00018 in/ft (0.015 mm/m)	Las. Flatness: 0.02 mm/m Las. Sqrness: 0.01 mm/m Pent. Flatness: 0.02 mm/m Pent. Sqrness: 0.01 mm/m	Not specified	n/a
Roll-to-Roll parallelism measuring accuracy	.000045 in/ft (0.0038 mm/m)	.00048 in/ft (0.040 mm/m) <i>(Total accuracy: las. + penta)</i>	Not specified	Accuracy not specified. Resolution: 0.008 mm/m
Penta Prism Step Error	+/- .0001 in. (+/-0.0025 mm)	1.0 mm**	n/a	n/a
Tripods Required	1	2	1	0
Resolution of Measurement	.00002 in. (0.0005 mm)	.00004 in. (0.001 mm)	.0010 in. (0.025 mm)	.00005 in/ft (0.004 mm/m)
Detector PSD Size	33x12 mm	20x20 mm	n/a	n/a
Operating Range	100 feet (30 m) in Radius	Not specified	100 feet (30 m)	Not specified
Software Required?	No	Yes	No	Yes
Manpower Required to Run System	1 optical technician	2 optical technicians	2 optical technicians	1 service engineer

* Gyroscopes not available for purchase. Service only. ** European systems do not calibrate Penta Prism centering, a source of large errors.

Parallelism Accuracy: HLI's L-742 Dual Scan® Technology vs. The Competitor's Pentaprism

HLI's Laser Transfer Method

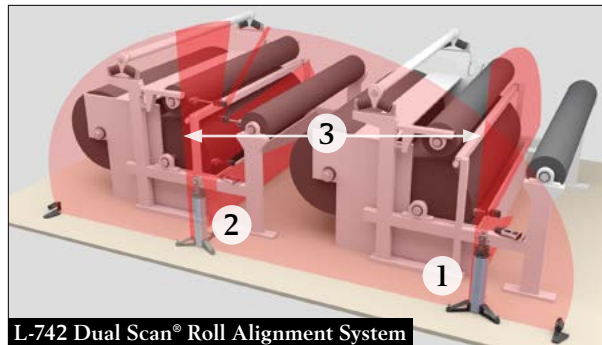

- 0.0188 mm/m Plane Flatness/Squareness
- 0.015 mm/m Plane Squareness
- $(1) - (2) = 0.0038$ mm/m Parallelism Error since Squareness Error Does Not Add in!
- 0.02 mm/m Beam Squareness/Flatness
- 0.02 mm/m Beam Squareness/Flatness
- $(4) + (5) = 0.040$ mm/m Parallelism Error Between 2 Beams!
- Additional Step Error of up to 1.0 mm

When using HLI's Laser-Transfer Method and a reference roll, the squareness between the L-742's laser planes is effectively eliminated when moving the laser from section to section. This means the measuring laser plane is parallel to where it was upon the initial setup to within the combined flatness of the laser planes or .000045 in/ft (0.0038 mm/m)!

Competitor's Pentaprism Method

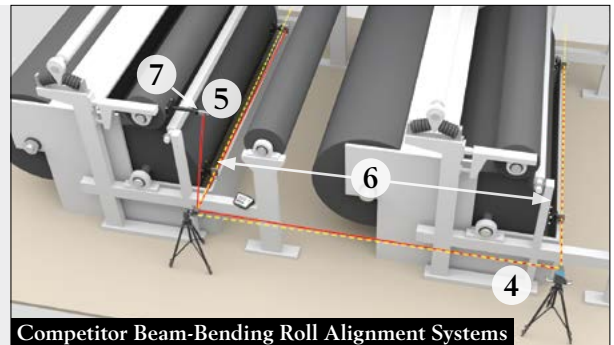

When using the Pentaprism Method with a reference roll, after the Pentaprism is moved to another location along the machine, the laser beam at the second location will not be parallel to the laser at the reference roll by up to .0005 in/ft (0.040 mm/m). Not very good for 3-7 meter rolls! Furthermore, rotating the prism to reach and upper or lower roll could result in an additional error of up to .040" (1.0 mm).

How L-742 Works for Roll Alignment

Here's how the process works for using a reference roll as the laser datum to measure rolls for parallelism to the reference roll.

1. The L-742 is placed on the L-106 stand outside the machine near the reference roll at the side of the machine and leveled.

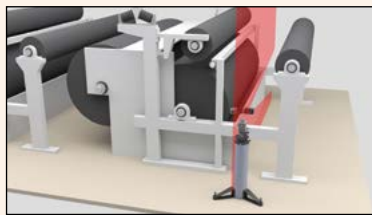

L-742 mounted on L-106 with Target #1 about to be aligned to the reference roll

2. A-1519-2.4XBE Target #1 is placed on the reference roll horizontally at the closest point to laser, is leveled and zeroed in Read16 PDA software. Target #1 is then moved to the far end of the roll.

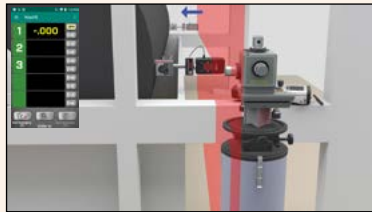

L-742 being adjusted to be parallel to reference roll

3. Laser Plane #1 (LP#1) is then "Bucked-in" or tilted until Target #1 reads zero at the far point. Target #1 is then moved back to the near point and re-zeroed and the process is repeated until the target reads zero at both locations.

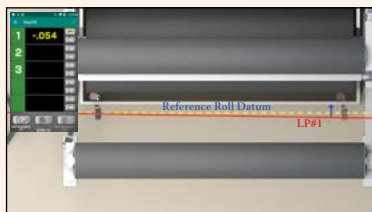

L-742 being adjusted to be parallel to reference roll

4. The laser plane is now parallel to the reference roll.

5. Since the LP#2 is perpendicular to LP#1, LP#2 becomes the offset centerline of the mill. This offset centerline has a range of 100 feet (30.5 meters) on both sides of the laser.



L-742 Aligned to Reference Roll

6. Now we place Target #2 & #3, on floor fixtures at both ends of the machine and are adjusted until the laser hits the middle of the target windows. The targets are then zeroed, establishing the offset centerline, and are not touched during the remainder of the alignment.

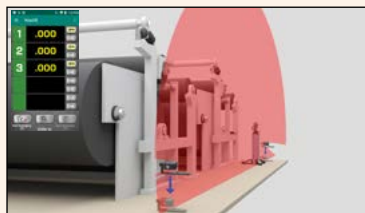

Installing #2 & #3 A-1519-2.4XBE Targets with T-1500 Floor Fixture to LP#2

7. To check the parallelism of a section of rolls, the L-742 and L-106 stand are moved along the offset centerline to the desired section and the laser is positioned so LP#1 is about 4-5' from the roll to be measured. The L-742 is then leveled.

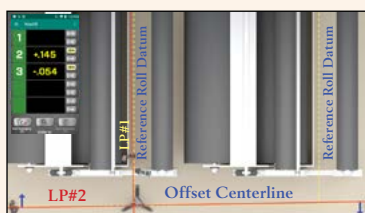

L-742 transferred to new location with laser being aligned to reference targets.

8. Then the yaw adjustment on the laser base is adjusted to tilt LP#2 until both Target #2 & #3 show the same readings, which means LP#2 is now parallel to the offset centerline.

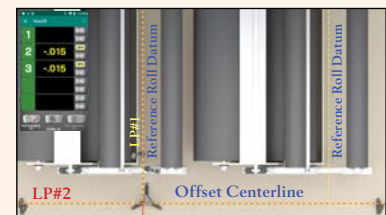

L-742 transferred, aligned to reference targets and ready to measure the roll

9. Now to measure one of the rolls for parallelism, Target #1 is placed horizontally on the roll closest to the laser and zeroed. It is then moved to the far end of the roll to measure the alignment. A +.025" reading means the far end of the roll is pointing to the right relative to the reference roll.

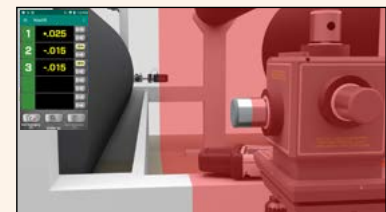

L-742 measuring roll for alignment. Data shows an error of +.025" (+0.98 mm) so the far end of the roll is angled to the right.

10. With targets producing live readings, the roll can then be adjusted until the target reads zero, which means the roll is aligned and parallel to the reference roll. Since the laser generates a plane, rolls up to 100 feet (30.5 m) in elevation in that section that are within 2 feet (610 mm) of the laser plane can be measured for parallelism without changing the setup of the laser.



L-742 Aligned to reference targets measuring multiple rolls from the same setup.

Specifications

L-742 Dual-Scan® Roll Alignment System

Weight	Laser: 3 lbs. (1.3 kg) Base: 4.8 lbs. (2.2 kg) Battery Pack: 1 lb. (0.45 kg)
Material	Laser: Aluminum and stainless steel Base: Aluminum
Laser Type	Class II visible diode, 635 nM wavelength (class 1 in Scanning Mode); 0.160" (4.06 mm) beam diameter
Beam Power	0.9 mW per straight beam
Beam Stability	.0001"/hr/°F (0.005 mm/hr/°C) translational 0.2 arc sec./hr/°F (0.36 arc sec/hr/°C) angular
Laser Plane Flatness	<ul style="list-style-type: none"> • 180/360° Sweep: 0.5 arc sec (.00003 in/ft or 0.0025 mm/m), plus translational error of ± .00015" (0.0038 mm) • 90° Sweep: 0.25 arc sec (.000015 in/ft or 0.0013 mm/m) plus translational error of ± .000075" (0.00019 mm).
Beam/Plane	<ul style="list-style-type: none"> • Left-to-Back Plane squareness 3 arc secs (.00018 in/ft or 0.015 mm/m);
Operating Range	100 feet (30.5 m) in radius
Operating Modes	2 beams or 1 or 2 continuously rotating laser planes in any combination, individually switched
Power Supply	9V DC external battery pack (4 cells) or 115V AC adapter
Power Draw	(See chart, below)
Coarse Adjustment Range	± 3 degrees
Fine Adjustment Range	± 0.3 degrees
Fine Adjustment Resolution	.001" (0.025 mm) in 100 feet (30.5 meters)

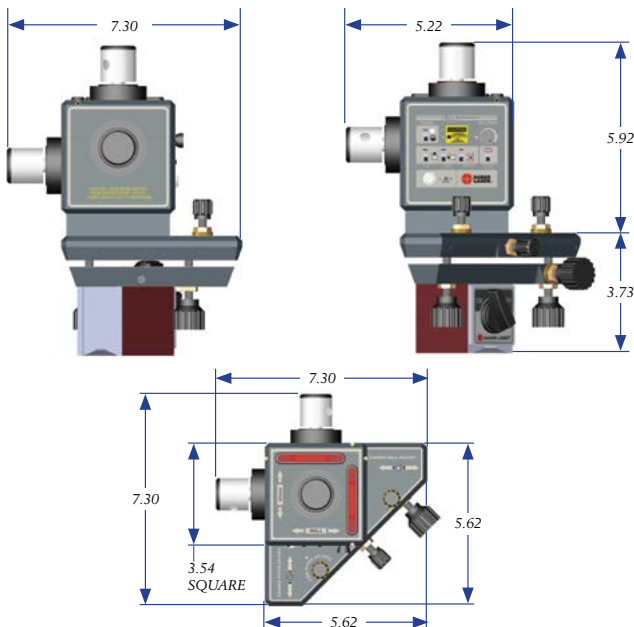

A-1519 Wireless Target

Resolution	.00002" (0.0005 mm)
Linearized Accuracy	±.00015" (±0.0038 mm) over ± 14 mm of PSD
Detector Size/Type	2-Axis PSD 1.3" x 0.51" (33x13 mm)
Operating Range	100 feet (30.5 m) from laser to target
Target Angle Acceptance Range	± 10°
Battery Life	11.5 hours continuous duty
Operating Temperature	35° F to 140° F (2° C to 60° C)
Power Supply	7.5-12vDC, 500mA
Size	2.00" W x 4.11" H x 1.75" D (50.8 mm x 104.4 mm x 44.5 mm)
Weight	13.5 oz. (383 grams)
Wireless Range	150 feet (46 m)*
Magnetic Base Size	2.00" W x 3.09" H x 4.14" D (50.8 mm x 78.5 mm x 105.2 mm)
Magnetic Base Weight	2.78 lb. (1.26 Kg)

* See the A-1519-2.4XBE Datasheet for radio frequency details. Wireless range may be limited by obstructions, antenna type and orientation. Outdoors line-of-sight range, with dipole antenna, may be greater.

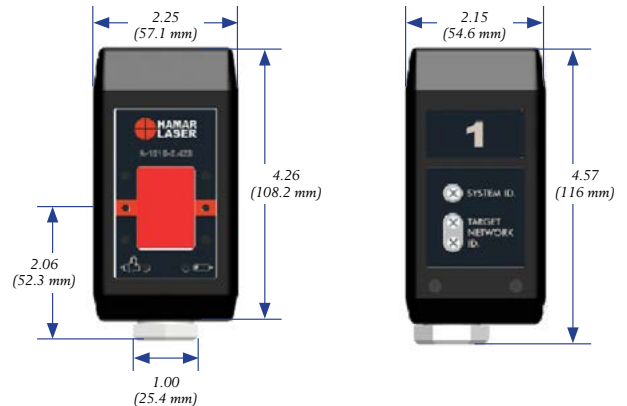

Hamar Laser Instruments, Inc.
5 Ye Olde Road, Danbury, CT 06810
Phone: +1-203.730.4600 • Fax: +1.203.730.4611
Int'l: +1.203.730.4600
E-mail: sales@hamarlaser.com
www.hamarlaser.com

