

The A-1511 Wand Bore Fixture

A-1511A
A-1511B

Speeds data taking for steam turbine bores with diameters from 10 inches to 96 inches



The A-1511A Wand Bore Fixture with the A-1519-2.4ZB Target



The A-1511B Wand Bore Fixture with the A-517 Target

Target Features

- Fixtures use two fixed-length legs approximately equal to the radius of the bore, one leg with a measuring tip and one for support.
- The A-1511A works with Hamar Laser's A-1519-2.4ZB. Target for bore diameter measurements from 10 inches (254 mm) to 96 in. (2.44 m).
- The A-1511B works with Hamar Laser's A-517 for bore diameter measurement from 10 inches (254 mm) to 96 in. (2.44 m).
- Both fixtures provide high levels of repeatability for faster measurement-taking to help reduce overhaul alignment times by up to 50 percent.



5 Ye Olde Road, Danbury, CT 06810 USA

Phone: (800) 826-6185 or +1-203-730-4600 • Fax: +1-203-730-4611

E-mail: sales@hamarlaser.com • Internet: <http://www.hamarlaser.com>

For a list of our distributors, please visit: http://www.hamarlaser.com/intl_distributors.htm

Using the A-1511 Targets

To take a reading, place the measuring foot of the A-1511 on the left side of the bore. Adjust the support foot until the horizontal axis of the readout shows less than .01" (0.25 mm). Using the Top Dead Center Method (see figure), zero the vertical axis of the readout. Repeat the same process to record the data (vertical axis) for the bottom of the bore. Record the final set of data by placing the measuring tip on the right side of the bore. The 3 data points are combined to give the horizontal and vertical alignment data for the bore.

This "sweeping-through-the-arc" method is very similar to what is done using an inside micrometer and tight wire, and eliminates potential errors if the target is not at top-dead center.

Once all the measurements are recorded, they can then be entered into a spreadsheet to determine the component moves. After the moves have been determined, the A-1511 can be used to align the individual components to their calculated locations. The laser and reference targets do not have to be repeatedly set up and taken down when moving or replacing components, resulting in substantial time savings.

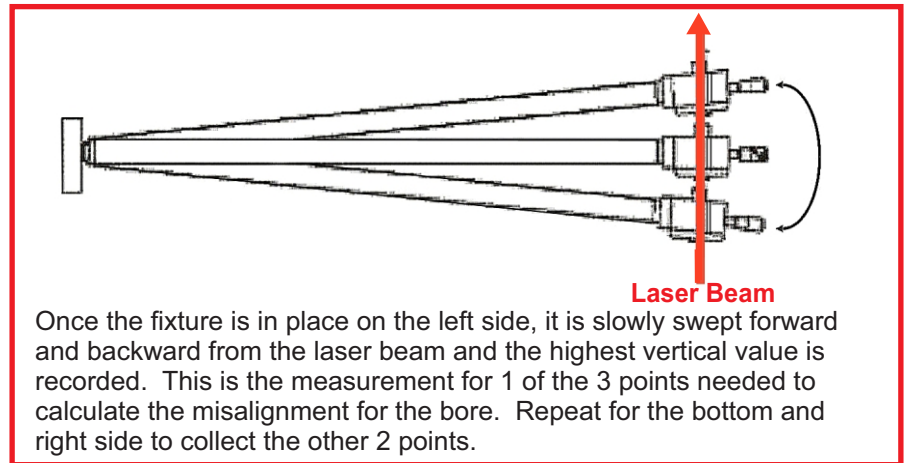
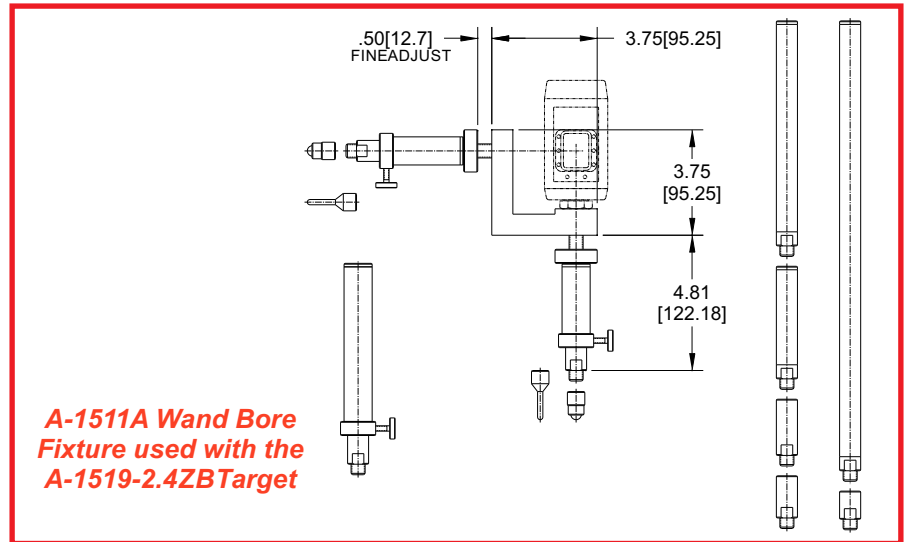

Finding Top Dead Center with the A-1511 Target

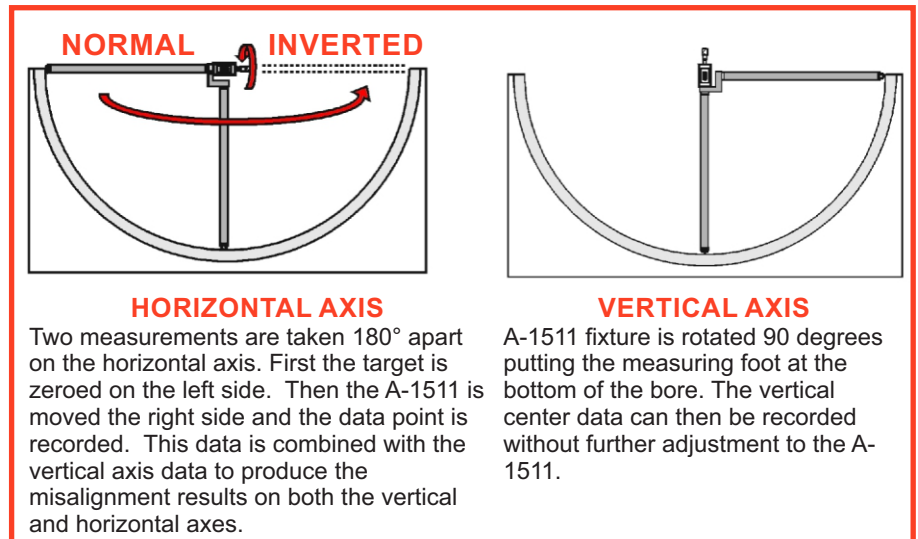

Taking Measurements with the A-1511 Target