

## Features & Benefits

### 1. Remote wireless communication.

No annoying cables to deal with because the S-650 features remote IR communication. Target data is sent instantly via an extremely robust, highly reliable FM-based IR link to the CPU for real-time processing, analysis and display.

### 2. Sub-micron resolution (.00004").

With a fully linearized measurement cell, no coupling alignment system offers better accuracy than the S-650. Angular accuracy is 10 micro radians. Vertical resolution is less than 1 micron. Horizontal is less than 0.2 microns.

### 3. Set up system in less than 5 minutes.

Hamar Laser alignment systems are designed to be "operator friendly." By using adjustable laser beam, quick-set brackets and an IR link, set-up time drops dramatically. Display misalignment data and calculate shims and moves in as little as 5 minutes. The S-650 even allows alignment of vertical pump configurations.

### 4. Automatic rotation sensor makes uncoupled alignment easy.

To measure misalignment, pick a starting point (e.g. 9 o'clock), move to the end point (e.g. 3 o'clock), or anywhere else in the circle, with no stopping in-between and no buttons to push. Automatic rotation sensor and counter weights make uncoupled alignments much easier.

### 5. Large color display of data and misalignment graphics.

The S-650 includes a laptop computer with the largest color graphics display in the industry for easier viewing.

### 6. Sweep angle can be as little as 60°.

Hamar Laser systems can measure within the confines of a smaller arc, allowing accurate results even in cramped, inaccessible conditions.

### 7. 4-Axis simultaneous live graphics.

Dynamic graphics in 4 axes *instantaneously* show alignment corrections as they are being made. Software allows the user to change system averaging to dampen fluctuations caused by both large motor footprints and air turbulence, especially over long distances. Includes soft foot routine.

### 8. Vertical pump alignment made easy.

Shim values for vertical pump flanges are always different from normal motor shim calculations. The S-650 is the only system on the market to offer color vertical pump capability with live motor graphics in 4 axes.

### 9. 40mm target measuring range handles large thermal offsets.

The S-650 features the largest cell size on the market — double the vertical height of our competitors. Thermal expansion offsets to 1" can be easily accommodated.

### 10. Target and laser are pre-aligned to brackets.

No need for extra equipment when doing rough alignment because the laser and targets are pre-aligned to the brackets, saving hours off of pre-alignment set-up for new installations.

### 11. 30-Foot operational range between laser and target.

The extended sensing range of the S-650 target means that longer jack shafts with lengths up to 30' can be easily measured and aligned.

### 12. Complete systems affordably priced.

All systems include laser, 5-axis target, IR com-links, case, brackets and ruggedized laptop computer. Optional accessories include offset brackets, shim kits, counter weights and fixtures for non-rotating shafts and color printer.

## Model S-650 Coupling Alignment System

### L-775 Laser

Type	Sealable dual beam laser visible-diode, class II
Wavelength	670nm
Beam Power	<0.9 mW
Operating Range	30 ft. (9.1m) — see manual for limitations
Power Supply	7.4V rechargeable battery with AC adapter
Battery Life	50 hrs. continuous duty
Size	3.88"W × 3.76"H × 1.68"D (98.6mm × 95.5mm × 42.7mm)
Weight	1.1 lbs. (0.5kg)

### T-1275 Target

Type	Sealable 5-axis target with infrared communication module
Internal Resolution	1.0 micron vertically, 0.2 micron horizontally
Angular Accuracy	2 arc sec (10 micro radians) or better vertically, 0.5 arc sec (2.5 micro radians) or better horizontally
PSD Sensor	40mm vertical range (±20mm), 10mm horizontal range
Rotation Sensor	Inclinometer (0.1° resolution)
Power Supply	7.4V rechargeable battery with AC adapter
Battery Life	14 hrs. continuous use
Size	3.88"W × 3.76"H × 2.64"D (98.6mm × 95.5mm × 67.1mm)
Weight	1.5 lbs. (0.7kg)

### A-908 FM-Based Infrared Receiver Target Interface

Frequency	3.5MHz
Range	20 ft. (6m) (reflected), 50 ft. (15m) (direct line of sight)
Baud Rate	19.2kb
Target Reading	
Transmission Rate	Up to 15 readings per second, depending on mode
Power Supply	9V lithium Ultralife® U9VL
Battery Life	48 hrs. continuous duty
Size	3.75"W × 3.00"H × 1.31"D (95.2mm × 76.2mm × 33.3mm)
Weight	0.5 lb. (0.2kg)
Cable	3 ft. (0.9m) coiled cord with DB9 connector

### Computer

Type	"Shop-hardened" laptop with touch screen, environmentally sealed with shockproof hard drive, spill resistant keyboard and magnesium cover. Windows 95 OS standard.
------	--

### A-907 Bracket Set

Brackets	0.5"W (12.7mm) with magnetic attachments for coupling flanges, etc.
Shaft Range:	
Standard Bracket Set	.375" diameter to 5.0" diameter (9.5mm to 127.0mm)
Link Chain Clamp Set	5"+ diameter to 12" diameter (127.0mm to 304.8mm) Can accommodate shafts up to 18" diameter (457.2mm) by adding additional chain
Chain Type	#35 roller chain, 3.3 ft. long (1m)
Fixture Rods	(4) 6" long (152.4mm), (4) 12" long (304.8mm)

## Specifications

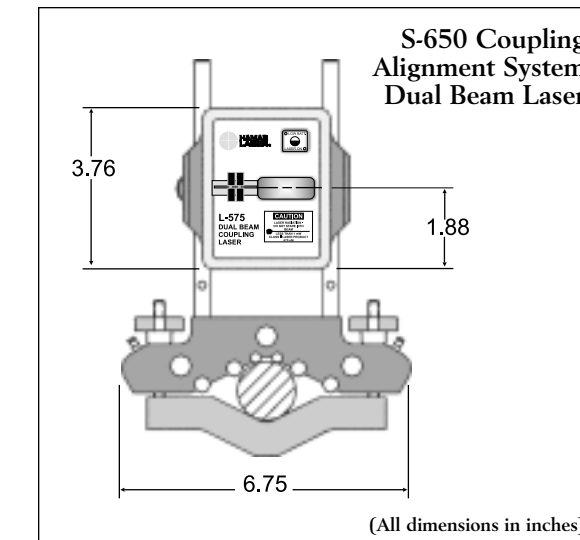

(All dimensions in inches)

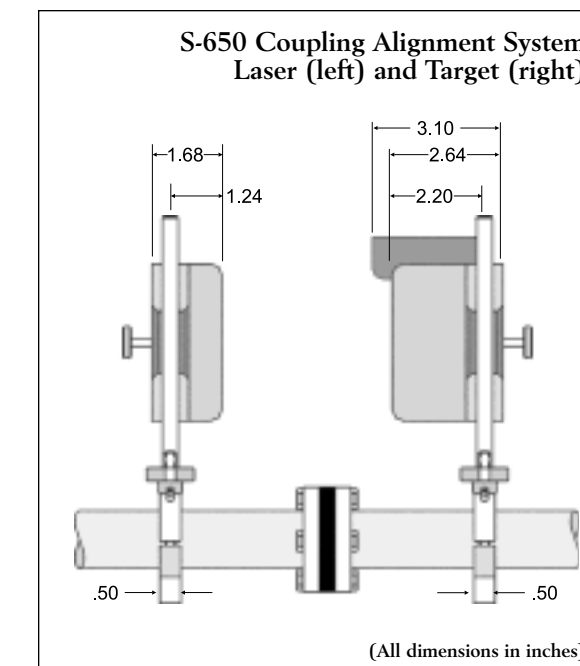

(All dimensions in inches)



**HAMAR LASER**  
Hamar Laser Instruments, Inc.  
5 Ye Olde Road, Danbury, CT 06810  
Phone: 800.826.6185 • Fax: 203.730.4611  
E-mail: sales@hamarlaser.com  
www.hamarlaser.com

## S-650 Coupling Alignment System

A new generation of 5-axis, real-time coupling alignment systems.



# The Best Choice in Coupling Alignment is Easy to See

# Clear, Concise Color Graphic Displays

# Quality, Accuracy and Complete Mounting Flexibility

- 1 • Largest target cell size on the market.
- 40mm target measuring range handles large thermal offsets.
- Sub-micron resolution (angular accuracy is 10 micro radians).
- Automatic target sensing of "start" and "stop" cycles.
- Sweep angle can be as little as 45°.
- 2 • Robust FM-based remote wireless communication eliminates bulky cabling.
- 3 • Up to 30-foot operational range between laser and target.
- Adjustable beam for quick set-up.
- 4 • 4-axis simultaneous live graphics.
- Large, concise display of data and misalignment graphics.
- 5 • Real-time processing allows viewing of alignment corrections as they are being made.
- Ruggedized laptop computer designed for shop-floor environments.
- 6 • Target and laser are pre-aligned to brackets.
- Many flexible mounting configurations available.



Properly aligned couplings can prolong motor, pump, bearing and seal life, increase productivity, and reduce costly downtime due to unplanned maintenance and repairs. Now Hamar Laser — the first to introduce real-time, 4-axis data display — offers a new generation of coupling alignment systems that simplifies the task of detecting, then fixing, misalignment problems.

Case histories have demonstrated that laser alignment of motors alone will reduce electrical consumption significantly — by as much as \$150,000 annually in one customer study. Your immediate savings could pay for a complete system in just a matter of months. Alignment times can also be cut by 66%, or more, versus conventional, less accurate alignment methods.

The S-650 Coupling Alignment System combines laser-accurate, 5-axis, dynamic, real-time measurement with innovative features like robust, FM-based IR remote wireless communication and the largest, clearest color display of data and misalignment graphics available anywhere.

All S-650 Coupling Alignment Systems include laser, 5-axis target, IR com-links, case, mounting brackets and laptop computer.

## Alignments Done in Five Easy Steps

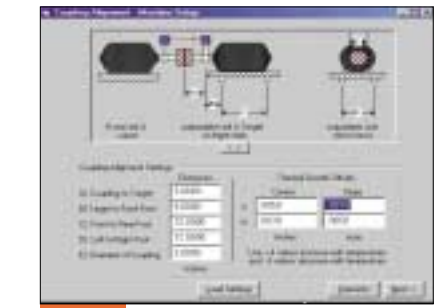

**Step 1** Enter machine dimensions, tolerances and thermal offsets for accurate shim and move calculations.

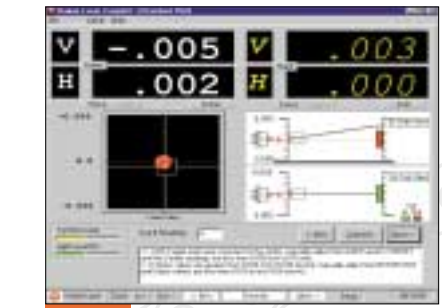

**Step 2** Set up laser/target and adjust readings <0.030" and use for rough angular alignment on new installations.



**Step 3** Perform simple, soft-foot routine to eliminate time-consuming alignment problems caused by soft feet.

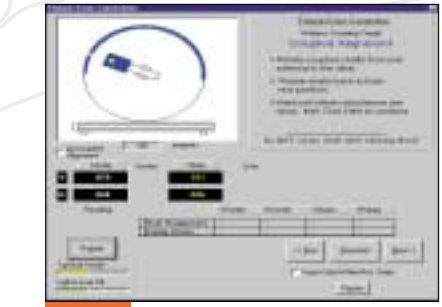

**Step 4** Rotate shafts to any clock positions to determine mounting errors. Rotation sensor automatically senses starting and stopping points.

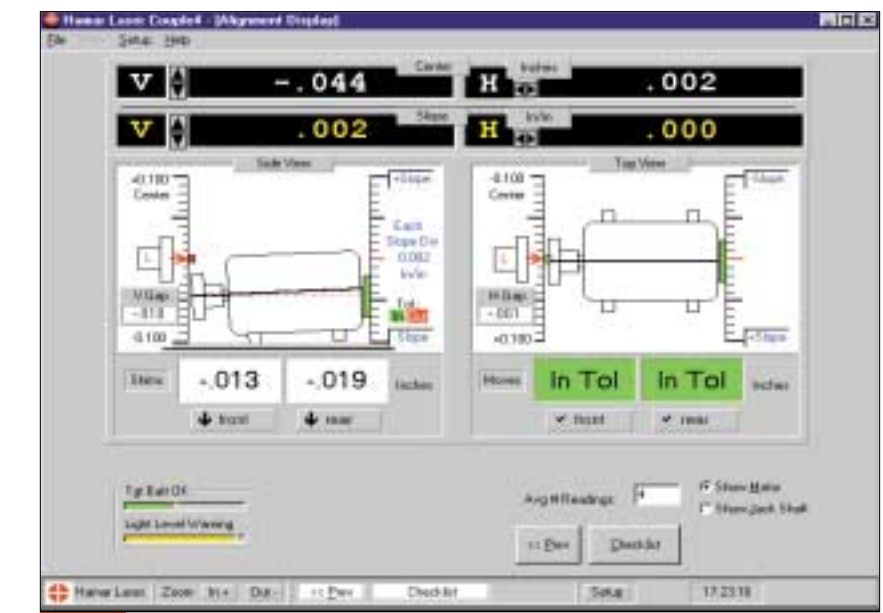

**Step 5** Provides shim values, horizontal moves and a live alignment status for all 4 axes simultaneously. Shim box turns green when alignment tolerances are met.

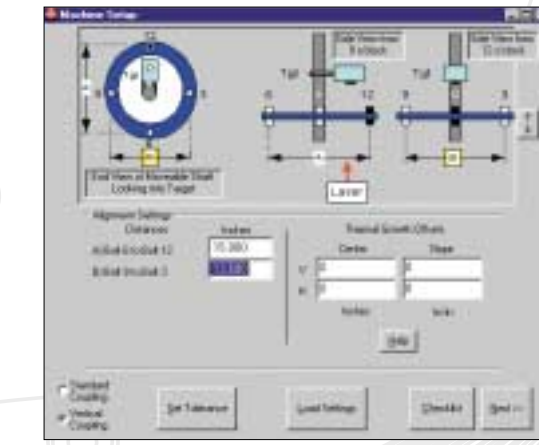

**Vertical Pump Setup Screen.** Enter the dimensions, tolerances and thermal offsets for accurate calculation of vertical pump shim values and moves.

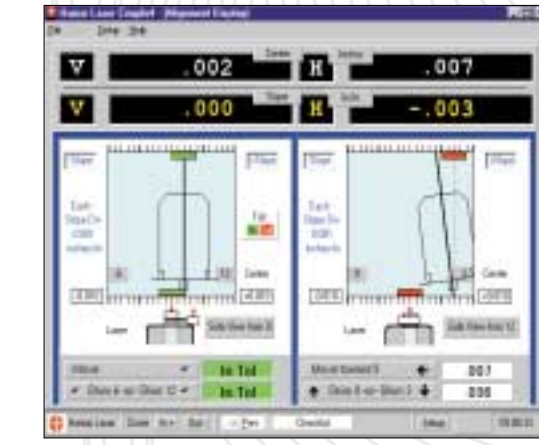

**Vertical Pump Misalignment Screen.** Provides shim values and moves for vertical pumps and a live 4-axis alignment status. Shim box turns green when alignment tolerances are met.



**Laser**  
The L-575 uses two adjustable, visible-diode Class II laser beams with an operating range of up to 30'. Angular accuracy of the system is guaranteed to 10 micro radians. Set-up time is minimal. In most cases, you can show misalignment data and calculate shims and moves in as little as 5 minutes.



**Infrared Data Receiver**  
Unlike competitive systems that rely upon unstable AM frequencies, our in-house designed A-908 wireless IR link is an extremely robust, FM-based unit. Data is sent up to 15 times per second via the most reliable IR link on the market today. Successfully proven in field use, at distances of 120', by a major aircraft manufacturer since 1994.



**Target**  
The T-1275 features a true 5-axis target that reads both horizontal and vertical center and angle measurements simultaneously. Target data is sent instantly via an IR link to the CPU for real-time processing, analysis and display of misalignment data. Largest cell size on the market accommodates thermal growth offsets up to 1".



**A-907 Bracket Set**  
Standard mounting fixture sets are designed to work with shaft diameters ranging in size from 3/8" to 12" - 18" with optional mounting kit.